

R E S T R I C T E D

AIR PUBLICATION

2548A

VOLUME I

47.439.

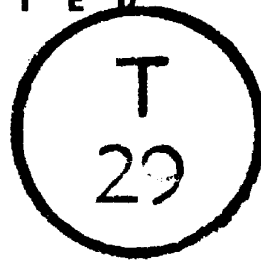

TRANSMITTERS T. 1154 SERIES AND RECEIVERS R. 1155 SERIES

Prepared by direction of
the Minister of Supply

Promulgated by Command
of the Air Council

AIR MINISTRY

Reprinted April, 1960

AMENDMENT RECORD SHEET

Incorporation of an Amendment List in this publication is to be recorded by signing in the appropriate column and inserting the date of making the amendments.

A.L.No.	AMENDED BY	DATE
1 to 9	Incorporated in this reprint	Apr. 1960
10		
11		
12		
13		
14		
15		
16		
17		
18		
19		
20		
21		
22		
23		
24		
25		
26		
27		
28		
29		
30		
31		
32		
33		
34		

A.L.No.	AMENDED BY	DATE
35		
36		
37		
38		
39		
40		
41		
42		
43		
44		
45		
46		
47		
48		
49		
50		
51		
52		
53		
54		
55		
56		
57		
58		
59		
60		
61		

(Continued overleaf)

RESTRICTED

A.L.No.	AMENDED BY	DATE
62		
63		
64		
65		
66		
67		
68		
69		
70		
71		
72		
73		
74		
75		
76		
77		
78		
79		
80		
81		
82		
83		
84		
85		
86		
87		
88		
89		
90		
91		
92		

A.L.No.	AMENDED BY	DATE
93		
94		
95		
96		
97		
98		
99		
100		
101		
102		
103		
104		
105		
106		
107		
108		
109		
110		
111		
112		
113		
114		
115		
116		
117		
118		
119		
*120		
121		
122		
123		

★An Amendment Record Continuation Sheet (R.A.F. Form 2096B.) will be required when this page is full. Order it now.

*This leaf issued in reprint
September, 1947*

A.P.2543A, Vol. I

NOTE TO READERS

Air Ministry Orders and Vol. II, Part 1 leaflets either in this A.P., or in the A.P's listed below, or even in some others, may affect the subject matter of this publication. Where possible, Amendment Lists are issued to bring this volume into line, but it is not always practicable to do so, for example when a modification has not been embodied in all the stores in service.

When an Order or leaflet is found to contradict any portion of this publication, the Order or leaflet is to be taken as the overriding authority.

When this volume is amended by the insertion of new leaves in an existing section or chapter, the new or amended technical information is indicated by a vertical line in the outer margin. This line is merely to denote a change and is not to be taken as a mark of emphasis. When a section or chapter is re-issued in completely revised form, the vertical line is not used.

Each leaf is marked in the top left-hand corner with the number of the A.L. with which it was issued.

LIST OF ASSOCIATED PUBLICATIONS

A.P. Reference	Subject
A.P.1186, Vol. I, Sect. 5, Chap. 18	Test set, type 65
A.P.1186, Vol. I, Sect. 6, Chap. 10	Aerial, screened loop, type 3
A.P.1186D, Vol. I, Sect. 8, Chap. 5	Power units, type 32, 32A, 32B, 33, 33A, 33B, 34 34A, 35, and 35A
A.P.1186E, Vol. I, Sect. 6, Chap. 4	Power units, type 114 and 115

LAYOUT TREE FOR A.P.2548A

A.P.2548A

TRANSMITTERS, T.1154 SERIES
and
RECEIVERS, R.1155 SERIES

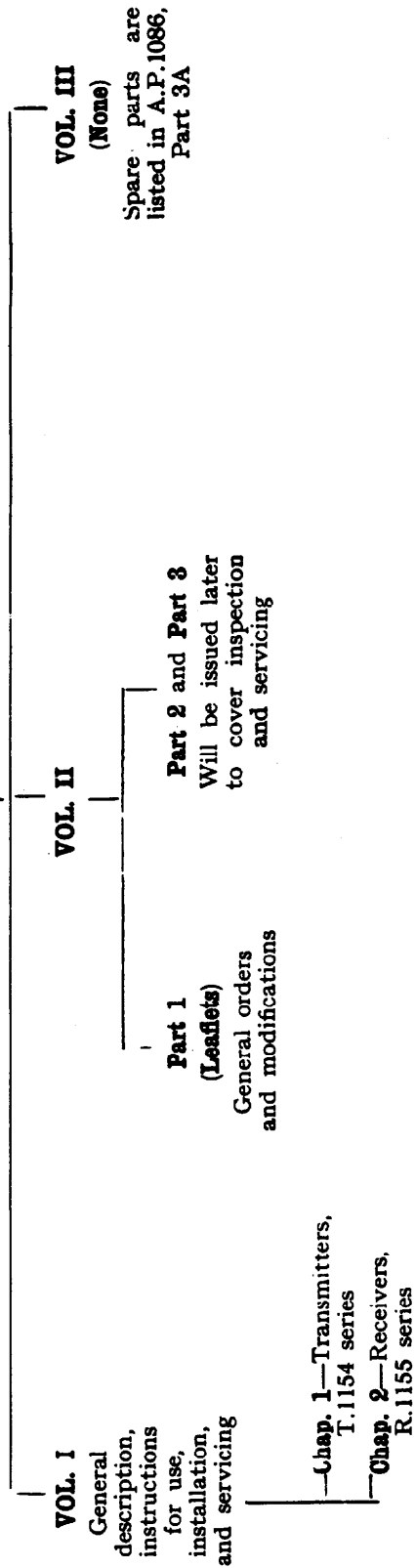

**TRANSMITTERS, T.1154 SERIES
AND
RECEIVERS, R.1155 SERIES**

LIST OF CHAPTERS

Note.—A list of contents appears at the beginning of each chapter.

CHAPTER 1—Transmitters, T.1154, T.1154A, B, C, D, E, F, J, K, L, M, and N

CHAPTER 2—Receivers, R.1155, R.1155A, B, C, D, E, F, L, M, and N

CHAPTER 3—Test Set, Type 65

CHAPTER 4—Artificial aerial, Type 21 (A.L.6)

CHAPTER 5—Loop aerials, Type 3 and 4 (A.L.7)

CHAPTER 6 — Installation in marine craft. (A.L.9)

CHAPTER 1

TRANSMITTERS, Type T.1154, T.1154A, B, C, D, E, F, H, J, K, L, M, and N

LIST OF CONTENTS

	<i>Para.</i>
Introduction	1
Frequency coverage	2
Pre-set frequency selection	5
Aerial systems and switching	7
Power supplies	10
General description	13
Master oscillator circuit	15
P.A. and output circuits	16
Sidetone and modulator valve	18
"Tune" position of master switch	19
"C.W." position of master switch	22
Listening through... ..	24
M.C.W. and R/T	26
Use of carbon or E.-M. microphones... ..	28
Magnetic relay Type 85 (keying relay)	30
Action of relay	32
Transmitters T.1154C, F, H, K, M	36
Frequency range switch	45
Variable meter shunt	48
Tuning and aerial matching devices	52
Transmitters T.1154, T.1154A, B, J, N	56
Transmitters T.1154D and T.1154E	58
Transmitter T.1154L	60
Aerial selector switch, Type J	61
Aerial selector plug board	65
Power supply circuits	67
Constructional details	68
Multi-click mechanism	84
Uni-click mechanism	89
Valves and power supplies	93
L.T. power units	95
H.T. power units	99
Power supplies of ground installations	102
Installation	104
Resistance units, Type 47, 52, 52A	105
Connectors, plugs, and sockets	111
Type 47 and 52 resistance positioning	115
Setting the resistance	117
External equipment	120
Operation	126
Tuning T.1154L on Range 2A	138
Tuning procedure on M.F.	139
R/T and M.C.W. operation	144
Notes on use of click-stops	145
Emergency working	149
Operating figures	151
Indications of meter M ₁	152

	<i>Para.</i>
Airborne fault finding	155
No input	157
Input low and dip absent or sluggish	161
High input, no dip	162
No dip	163
Sharp dip, but transmitter will not load up	164
No output	165
No sidetone	166
No modulation	167
General fault finding and servicing	168
Substitution tests	171
Trouble outside transmitter—	
Power units do not start	173
L.T. unit starts but not H.T. unit	179
Power units start but no input to transmitter	180
Trouble inside transmitter—	
General	185
Transmitter not working on any range	188
Transmitter not working on one range	199
Modulator trouble	202
Point-to-point testing	206
Insulation resistance	207
Mechanical inspection	209
Modifications to transmitter and associated equipment—	
Fitting of resistances R_{30} , R_{31}	210
Resistance R_7	213
M.F. range aerial tuning coil	215
Transmitter case screws	216
Additional element for Type 52 resistance	217
Security of sockets	218
Breakdown of milliammeter Type D	220
Re-wiring of H.T. fuse	221
Replacements for resistances R_{11} and R_{12}	222
Values and types of components	Appendix 1

LIST OF ILLUSTRATIONS

	<i>Fig.</i>
General view of T.1154M	1
Simplified circuit diagram, T.1154	2
Keying relay contacts	3
Circuit of T.1154C, F, H, K, and M	4
Circuit of T.1154, T.1154B, D, J, and N	5
Circuit of T.1154L	6
Aerial plug board	7
Aerial switching unit, Type J, theoretical connections	8
Input and starting circuit, L.T. power unit	9
Input and starting circuit, H.T. power unit	10
Rear view of T.1154M	11
T.1154M, Keying relay and output end	12
T.1154M, M.O. and frequency switch end	13
Top view of T.1154M	14
Underside view of T.1154M	15
T.1154L, front view	16
T.1154L, end view showing Range 2A variometer	17
T.1154L, top view	18
Multi-click mechanism	19
Uni-click mechanism	20
Connections of resistance, Type 52	21
Dummy aerial circuit	22
Adjustment and tests of magnetic relay, Type 85 (Keying relay)	23
Fitting of resistances R_{30} and R_{31}	24

**CONCISE DETAILS OF TRANSMITTERS, Types T1154, T1154A, B, C, D, E, F,
H, J, K, L, M, and N**

Purpose of equipment...	Airborne transmitters used with receivers of the R.1155 group, except the T.1154D and T.1154E, which are used with R.1188 in mobile ground stations.		
Type of wave	T.1154, T.1154B, T.1154C, T.1154D, T.1154F, T.1154H, T.1154J, T.1154K, T.1154L, T.1154M, T.1154N:—C.W., M.C.W. and R/T. T.1154A, T.1154E:—M.C.W., C.W.		
Frequency range	T.1154, T.1154A, T.1154B, T.1154J, T.1154N:—10.0 Mc/s–3.0 Mc/s and 500 kc/s. to 200 kc/s. in three ranges. T.1154C, T.1154F, T.1154H, T.1154K, T.1154M:—16.7–2.35 Mc/s and 500 kc/s. to 200 kc/s. in 4 ranges. T.1154D, T.1154E:—8 Mc/s–2.5 Mc/s and 500 kc/s. to 200 kc/s. in three ranges. T.1154L:—5.5–1.5 Mc/s and 500–200 kc/s. in three ranges.		
Frequency stability	Master oscillator control.		
Percentage modulation	70 per cent.		
Amplifier class	Class C, with suppressor grid modulation on M.C.W. and R/T.		
Microphone type	Carbon granule, or electro-magnetic with sub-modulator such as A.1134 or A.1134A.		
Valves	Master oscillator; sidetone and modulator; two indirectly-heated triodes, VT105 (Stores Ref. 10E/216). Power amplifier, two directly-heated pentodes, VT104 (Stores Ref. 10E/215).		
Power input	From 12 or 24-V. rotary transformers, supplied from aircraft electrical system in airborne installations, or from a.c. mains <i>via</i> a rectifier on the ground. 1,200 volts, 200 mA. H.T.; 6 volts, 4 amps. L.T.; 6 volts 2.5 amps. keying relay (approx. 280 watts total).		
Power output	50–80 watts; $\frac{1}{2}$ power on R/T and M.C.W.		
Approximate overall dimensions	<i>Length</i>	<i>Width</i>	<i>Height</i>
	17 $\frac{1}{2}$ in.	16 $\frac{3}{8}$ in.	11 $\frac{1}{4}$ in.
Weight	46 lb. 10 oz.		
Associated equipment...	R.1155 (Stores Ref. 10D/98), R.1155A (Stores Ref. 10D/820), R.1155B (Stores Ref. 10D/13045), R.1155C (Stores Ref. 10D/1105), R.1155D (Stores Ref. 10D/1331), R.1155E (Stores Ref. 10D/1332), R.1155F (Stores Ref. 10D/1333), R.1155L (Stores Ref. 10D/1477), R.1155M (Stores Ref. 10D/1597), R.1155N (Stores Ref. 10D/1667). Switch unit Type J (Stores Ref. 10F/126) or aerial plug board (Stores Ref. 10H/681). Power units.—Type 32 (Stores Ref. 10K/17), Type 32A (Stores Ref. 10K/13063) or Type 32B (Stores Ref. 10K/1474). Type 33 (Stores Ref. 10K/18), Type 33A (Stores Ref. 10K/13064) or Type 33B (Stores Ref. 10K/1470). Type 34X (Stores Ref. 10K/61), Type 34A (Stores Ref. 10K/13065). Type 34 (Stores Ref. 10K/19). Type 35A (Stores Ref. 10K/13066) or Type 35 (Stores Ref. 10K/20). <i>For use on ground.</i> —Power unit, Type 114 (Stores Ref. 10K/350) or Type 115 (Stores Ref. 10K/351). For mobile ground station, rectifier Type 26 (Stores Ref. 10D/745). Aerial ammeter (Stores Ref. 10A/12227 or 10A/12667).		

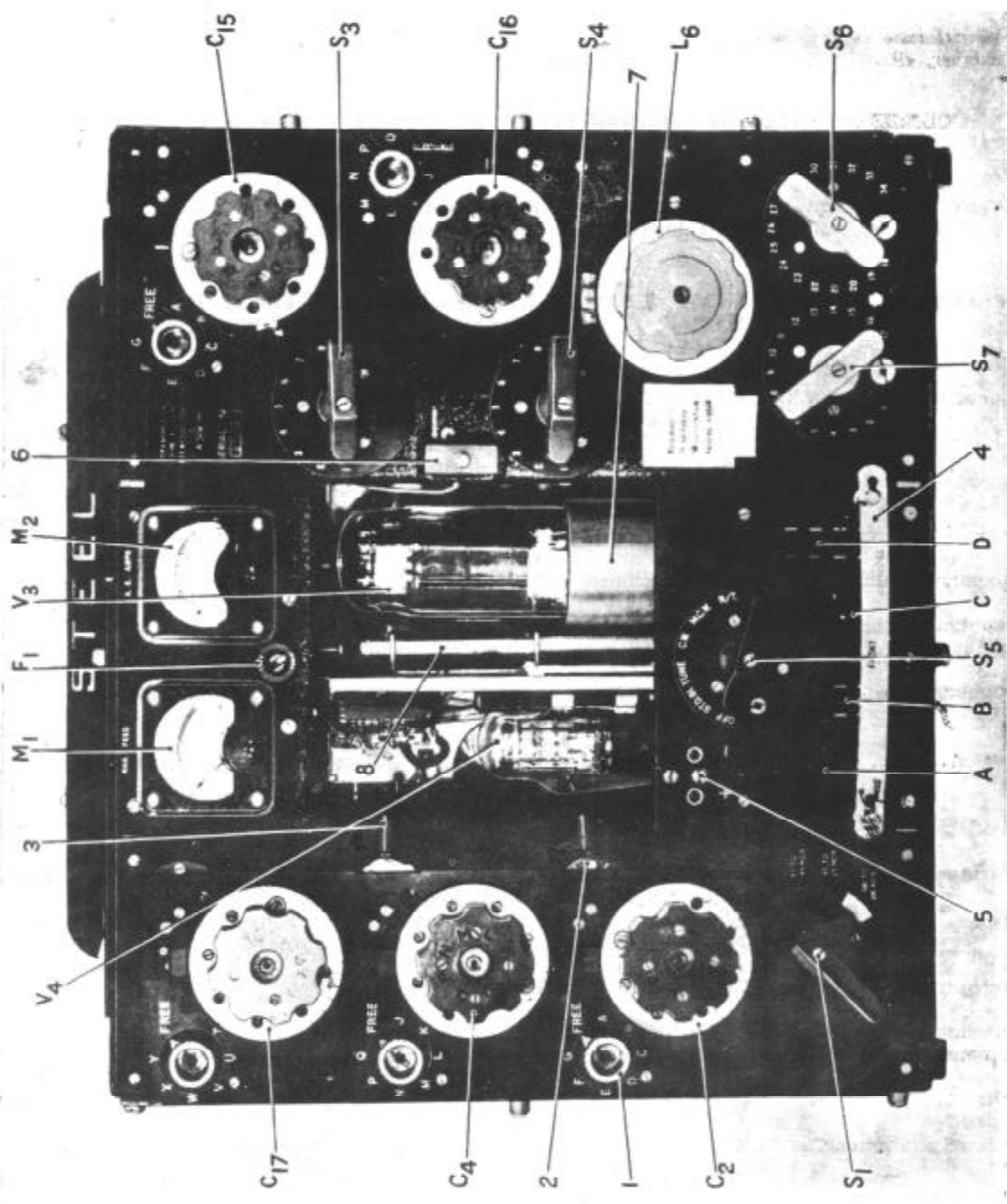

1. Selector knob of click-stop mechanism
2. 3. Vernier adjustments, M.O. tuning (operative only when click stops are in use)
4. Retaining bar for plugs and sockets
5. Microphone sockets
6. Plug for output circuit matching, RED range
7. Screening can
8. Spring-loaded pivot for anode connector

FIG. 1.—GENERAL VIEW OF T.1154M

CHAPTER 1

TRANSMITTERS, Types T.1154, T.1154A, B, C, D, E, F, H, J, K, L, M, and N

INTRODUCTION

1. Transmitters of the T.1154 series are designed primarily for installation in aircraft, to provide air-to-ground or air-to-air communication by W/T, and in all but two versions by R/T as well. Series N, is intended for installation in high-speed launches, and series D and E were introduced for mobile ground stations. Normally all these transmitters are used with receivers of the R.1155 series (see Chapter 2 of this publication). (A.L.S.)

Frequency coverage

2. Altogether there have been thirteen production varieties of the T.1154, the principal differences between them concerning frequency coverage and the provision or absence of R/T facilities. Component variations in the drive and output units, modifications of the "click-stop" mechanism for rapid selection of pre-set frequencies, and the use of steel or aluminium cases account for further versions. Table 1 enumerates the different types of transmitter and their frequency ranges. The colours stated in the table are those of the tuning controls for the ranges concerned.

TABLE 1
Frequency coverage of transmitters T.1154

T.1154, *T.1154A, T.1154B, T.1154J, T.1154N			
Range 1 (H.F.),	BLUE	10 Mc/s to 5.5 Mc/s	
Range 2 (H.F.),	RED	5.5 Mc/s to 3.0 Mc/s	
Range 3 (M.F.),	YELLOW	500 kc/s to 200 kc/s	
T.1154C, T.1154F, T.1154H, T.1154K, T.1154M			
Range 1 (H.F.),	BLUE	16.7 Mc/s to 8.7 Mc/s	
Range 2 (H.F.),	BLUE	8.7 Mc/s to 4.5 Mc/s	
Range 3 (H.F.),	RED	4.5 Mc/s to 2.35 Mc/s	
Range 4 (M.F.)	YELLOW	500 kc/s to 200 kc/s	
T.1154D, *T.1154E			
Range 1 (H.F.),	BLUE	8 Mc/s to 4.5 Mc/s	
Range 2 (H.F.),	RED	4.5 Mc/s to 2.5 Mc/s	
Range 3 (M.F.),	YELLOW	500 kc/s to 200 kc/s	
T.1154L			
Range 2 (H.F.),	RED	5.5 Mc/s to 3 Mc/s	
Range 2A (H.F.),	BLUE	3 Mc/s to 1.5 Mc/s	
Range 3 (M.F.),	YELLOW	500 kc/s to 200 kc/s	

*Note.—Transmitters marked with an asterisk provide C.W. and M.C.W. only. All others are for C.W., M.C.W., and R/T.

3. In all transmitters with three frequency ranges there are separate sets of tuning controls for each range, identified by colours as in the foregoing table. Series C, F, H, K, and M, however, use the same set of controls, coloured blue, for the two higher H.F. ranges.

4. Certain types of T.1154 are now obsolete or obsolescent and ultimately the series will be narrowed to three standard types for all applications. The position in this respect is shown in Table 2, the final standard versions being identified with a dagger. In the same table is shown the type of case, aluminium or steel, and of "click-stop" mechanism.

Pre-set frequency selection

5. The click-stop mechanism is arranged so that the tuning controls click into and are rigidly held in the correct position for pre-set frequencies. With the Multi-click system all the chosen frequencies are selected in turn as the tuning dials are rotated, and the operator sees which one is engaged at any moment by means of lettered tabs coming into view behind an aperture. The mechanism can be released to allow free rotation of the dials when setting up frequencies which have not been pre-selected.

6. The Uni-click mechanism on the other hand allows one click-stop to be brought into use at a time, the stop required being selected by turning a selector knob to the appropriate position on a lettered dial. Both mechanisms are fully described in para. 84 to 92.

TABLE 2

<i>Stores Ref.</i>	<i>Type</i>	<i>Case Aluminium (A) or Steel (S)</i>	<i>Click-stop Mechanism</i>	<i>Remarks</i>
10D/97	T.1154	A	Multi	Obsolete
10D/99	A	A	Multi	Obsolete
10D/196	B	A	Multi	Obsolescent.—Restricted to use in Halifax (B) only, but suitable for use in all bombers.
10D/198	C	A	Multi	Obsolescent.—Coastal version. Superseded by T.1154F.
10D/730	D	A	Multi	Obsolescent.—Provided for mobile ground stations, but superseded by T.1154K.
10D/731	E	A	Multi	Same construction as T.1154D.
10D/893	F	A	Multi	Obsolescent. Coastal version. Used in Halifax (G.R.) and Sunderland aircraft, and in trainers where the steel version is unacceptable.
10D/1180	†H	A	Uni	T.1154F with Uni-click mechanism. For Halifaxes and flying boats.
10D/1329	J	S	Multi	Obsolescent. Steel version of T.1154B for all bombers other than Halifaxes.
10D/1330	K	S	Multi	Obsolescent. Steel version of T.1154F. Will be superseded by T.1154M.
10D/1455	†L	S	Uni	
10D/1587	†M	S	Uni	As T.1154K with Uni-click stops.
10D/1588	N	S	Uni	Steel version of T.1154B with Uni-click stops.

Aerial systems and switching

7. When installed in aircraft the transmitters work into the aircraft fixed aerial on the H.F. ranges and into the trailing aerial on M.F. The appropriate aerial is selected by the frequency range switching of the transmitter, but to provide for occasions when the normal aerial may not be available an external aerial selector switch type J (Stores Ref. 10F/126) is provided which can override the transmitter switch and connect the H.F. output circuit to the trailing aerial or the M.F. output circuit to the fixed aerial. Other positions of this switch are arranged to cut off the transmitter H.T. supply when the aerials are earthed, or when the associated receiver is being used for loop D/F.

8. In some early installations an aerial plugboard (Stores Ref. No. 10H/681) is provided in place of the aerial selector switch and the desired aerial is connected to the transmitter, on occasions when the automatic internal switching does not fulfil the requirements, by the interchange of plug and socket connections.

9. Either carbon-granule or electro-magnetic type microphones may be used for R/T with the transmitters equipped for telephony transmission, but when electro-magnetic microphones are used it is necessary to incorporate a suitable sub-modulating device such as the intercommunication (I/C) amplifier A.1134 (Stores Ref. 10U/11500) or A.1134A (Stores Ref. 10U/90) to provide the necessary microphone gain. The change from carbon to electro-magnetic operation entails a minor internal adjustment of the transmitter (see para. 28, 29). A detailed description of the amplifier A.1134 is given in Sect. 4, Chap. 2 of A.P.1186.

Power supplies

10. Power supplies for the airborne equipment are derived from the general aircraft electrical supply system of nominal 12-volt or 24-volt rating, through two rotary transformers with the necessary smoothing and filtering circuits. One of these units (referred to as the H.T. power unit) supplies 1200 volts H.T., and the other (the L.T. power unit) provides 6.3 volts L.T. The L.T. power unit is used, also, by the receiver installation, supplying H.T. and L.T. for the receiver, in addition to transmitter L.T.

† Denotes final standard version

11. When used in a ground installation the rotary transformers may be run from accumulators "floating" across a mains rectifier such as the power unit type 115 (Stores Ref. 10K/351), or the transmitter may be supplied direct from a.c. mains through a rectifier such as the power unit type 114 (Stores Ref. 10K/350), which is tapped to provide the correct voltage inputs.

12. The overall dimensions of a transmitter, in its case, are approximately $17\frac{1}{2}$ in. by $16\frac{3}{4}$ in. by $11\frac{1}{4}$ in. The weight of the instrument, complete with its suspension units and valves, is approximately 46 lb. 10 oz. The general appearance of a transmitter T.1154M is shown in fig. 1 and this illustration is representative of the remaining types except for the click-stop mechanism of the older versions.

GENERAL DESCRIPTION

13. Before considering the circuit arrangement of the transmitter it is necessary to understand the functions of the transmitter master switch (S_5 , fig. 1). This has six (or in transmitters without R/T, five) positions, labelled as follows: OFF, STD.BI, TUNE, C.W., M.C.W., R/T. In the STD.BI position the input circuit of the L.T. power unit is completed and the transmitter valves are heated by the 6.3 volts output of that unit. When the switch is turned to TUNE, 6.3 volts from the L.T. power unit are applied to the starting relay of the H.T. machine, which on running produces 1,200 volts for the transmitter anodes. The circuit from the L.T. power unit to the H.T. starting relay passes through the aerial selector switch type J and is broken there when the switch is in the D/F or EARTH positions.

14. The remaining positions of the switch are shown in the basic circuit diagram, fig. 2. No frequency range switching is shown in this diagram, for the sake of simplicity. The annotations of the tuned circuit components are those for the BLUE range, but the general circuit is similar on all frequencies except for the aerial tuning arrangements on M.F., which are described later, and are shown inset.

Master oscillator circuit

15. It will be seen from fig. 2 that the transmitter consists of a master oscillator stage driving two pentode power amplifying valves in parallel. Only one of the P.A. valves is shown in the simplified diagram. The master oscillator valve, V_1 , an indirectly-heated triode, has its tuned circuit, $L_1 C_2$, connected between grid and anode, and its H.T. supply is fed through a tapping point on the coil. This point is also in effect the cathode tap of the circuit, being at cathode potential from the point of view of R.F. by reason of its connection to earth *via* the condensers C_{18} , C_{19} . The circuit is therefore a series-fed Hartley oscillator. In this transmitter the cathodes are connected to chassis, which is however at a positive d.c. potential with respect to the H.T. negative line because of the voltage drop across the resistances R_9 , R_{10} through which the whole H.T. current flows from the chassis back to its negative supply terminal.

P.A. and output circuits

16. The M.O. stage is connected to the directly-heated pentode power amplifier valves V_2 , V_3 through the coupling condenser C_6 . On the BLUE range the P.A. tuned circuit is the coil L_4 with the condenser C_{15} in parallel. The aerial is coupled directly to this circuit through a variable tapping controlled by the switch S_3 (fig. 1) on the front panel. Similar arrangements, using a separate set of components, apply on the RED range of all transmitters except those of series C, F, H, K, and M. In these versions the end of the aerial coil remote from the P.A. valve anodes is not normally earthed, although provision is made for earthing it, through two series condensers, in the circumstances described in para. 55. The P.A. circuit is shunt-fed through the H.F. choke HFC_1 . A feed meter, M_1 is provided, and it should be noted that it reads only the current taken by the power amplifier valves. The input fuse F_1 carries the H.T. current to all valves in the transmitter.

17. On the YELLOW range the aerial itself provides the tuned circuit capacitance. The amount of inductance in the circuit is varied in steps by means of a tapped coil, a varying portion of which is short-circuited as the tapping is altered. The coil has a sliding iron-dust core for fine variations of inductance by permeability tuning. The anodes of V_2 , V_3 are connected to the aerial coil through a variable tapping, which enables the valve loading to be adjusted to the best advantage. These arrangements are shown in the inset of fig. 2, and it will be seen that the P.A. circuit is shunt-fed as on the H.F. ranges. An aerial ammeter, M_2 , is connected between L_8 and earth, to give an indication of aerial current.

Sidetone and modulator valve

18. The indirectly-heated triode valve V_4 acts either as a 1,200 cycle (approx.) oscillator to provide keying sidetone, or sidetone together with modulation of the transmitter output on M.C.W.; or as a modulator for R/T, when speech sidetone is also available from this valve provided a carbon microphone is in use. The modulating voltages are applied to the suppressor grids of the P.A. valves. Approximately 70 per cent. modulation is effected.

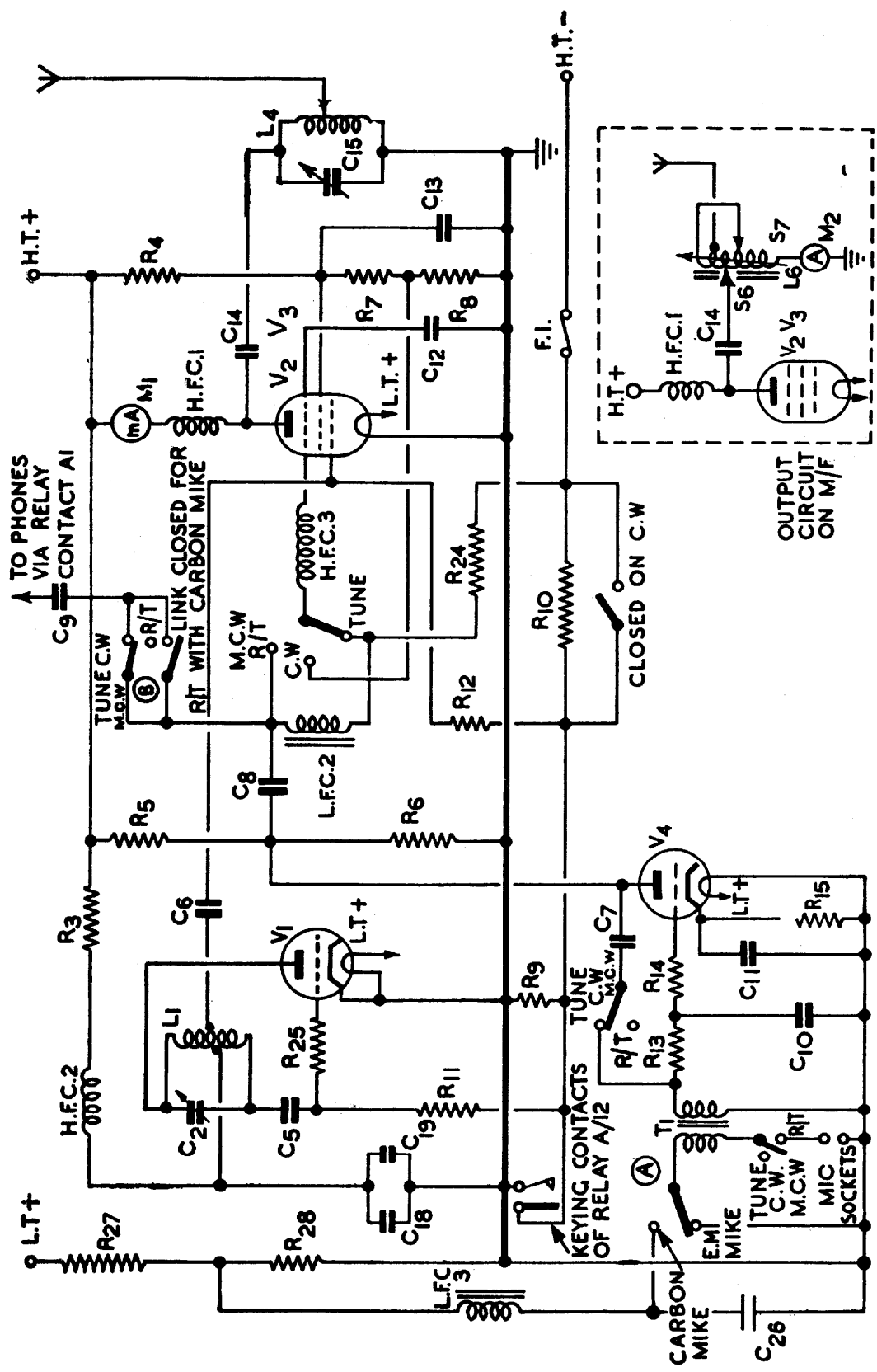

FIG. 2.—SIMPLIFIED CIRCUIT DIAGRAM, T.1154

"Tune" position of master switch

19. When the transmitter master switch is on TUNE and the key is up, the keying contacts of REL. A/12 are open, and the flow of H.T. current through the resistances R_9 , R_{10} renders the control grids of the master oscillator and P.A. valves so negative with respect to their cathodes that no oscillation takes place, and the P.A. stage passes no current. With the key down the relay contacts close, short-circuiting R_9 , so that the bias is removed from the control grids and the circuit oscillates. However, with the master switch at TUNE the resistance R_{10} is still in circuit and the suppressor grids of V_2 , V_3 are negative to cathode on account of the voltage drop across that resistance, the bias being of the order of 45 volts. This is sufficient to prevent excessive feed to the P.A. valves caused by misadjustment when tuning, and permits short-range communication to be carried on. It should be noted that the suppressor grids are at filament potential to R.F. on account of condenser C_{11} . The power output on TUNE is approximately one quarter of that on C.W.

20. When the transmitter is oscillating the M.O. valve V_1 receives automatic bias from the grid leak and condenser combination C_6 , R_{11} , the resistance R_9 being short-circuited as explained above, and the grid leak keyed to earth, *via* the keying relay contacts. The grid-stopper resistance R_8 suppresses parasitic oscillations.

21. A resistance R_3 in the H.T. positive line serves to reduce the anode voltage of the oscillator valve. When the key is up, the increased bias reduces the anode current, giving less voltage drop in R_3 and a higher anode voltage to V_1 , which helps this valve to commence to oscillate when the key is pressed. The increase of anode current then gives more drop in R_3 and the anode current then drops to the normal working value.

"C.W." position of master switch

22. On turning the master switch to c.w. the suppressor grids of V_2 , V_3 are joined to a point on the potentiometer formed by the resistances R_4 , R_7 , and R_8 connected across the H.T. supply and acquire a positive potential, although still at earth potential to R.F. by virtue of the by-pass condenser C_{11} . At the same time the resistance R_{10} is short-circuited. The positive potential on the suppressor grids is approximately 20 volts and provides full-power conditions of working. The control grids of V_2 , V_3 receive automatic bias from the grid leak and condenser R_{11} , C_6 .

23. It will be noted that the screen grids of V_2 and V_3 are also supplied from a tapping on the potentiometer formed by R_4 , R_7 , and R_8 . They are at earth potential to R.F. by reason of C_{11} .

Listening through

24. While the master switch is in the TUNE, M.C.W., or c.w. position the valve V_4 acts as an A.F. oscillator, anode-to-grid feedback being provided by the condenser C_7 . The A.F. voltages across LFC₂ are fed to the operator's telephones through contacts on the keying relay which are closed when the key is down. When the key is raised these contacts break and another relay contact connects the telephones to the output of the receiver. In this way the operator is provided with "listening through" facilities, being able to hear a station calling him in the intervals of his keying.

25. It must be appreciated that the note heard when the key is pressed is due entirely to the valve V_4 , which can be regarded in these circumstances as a valve buzzer, and gives no indication that the M.O. and P.A. stages are functioning correctly.

M.C.W. and R/T

26. With the master switch at m.c.w. V_4 continues to act as an A.F. oscillator, but now the voltages across LFC₂ are applied also to the P.A. suppressor grids *via* HFC₂ to modulate the output. At the same time the short-circuit is removed from R_{10} and the suppressor grids again receive a negative bias, which is varied by the modulating voltages.

27. On turning the master switch to R/T the anode-to-grid circuit of V_4 *via* C_7 is broken so that the valve ceases to oscillate and acts as an A.F. amplifier. The primary circuit of the microphone transformer is made, and the speech frequencies applied to the grid of V_4 appear amplified across LFC₂ and are passed to the suppressor grids of V_2 , V_3 , which again have a negative bias due to the voltage drop across R_{10} .

Use of carbon or E.-M. microphones

28. Two sockets on the transmitter panel allow for a modulating source to be connected. A plate inside the transmitter (but accessible from the back, as shown in fig. 11) engraved CARBON on one side and ELECTRO-MAGNETIC on the other can be turned round so that either label is showing

being held in position by six fixing screws. When the word CARBON is visible, link connections incorporated in the plate tap off a portion (2 volts) of the L.T. voltage from the junction of R_{27} and R_{28} for energising the microphone, and connect the operator's telephones in parallel with the input to the P.A. suppressor grids to provide him with sidetone.

29. When the plate is turned so that the word ELECTRO-MAGNETIC is showing, the microphone energising circuit is broken, as is also the link feeding sidetone to the telephones (see points A and B, fig. 2). In these circumstances it is the output of a sub-modulating amplifier (see para. 9) which is connected to the microphone sockets on the transmitter, and sidetone is provided from the amplifier.

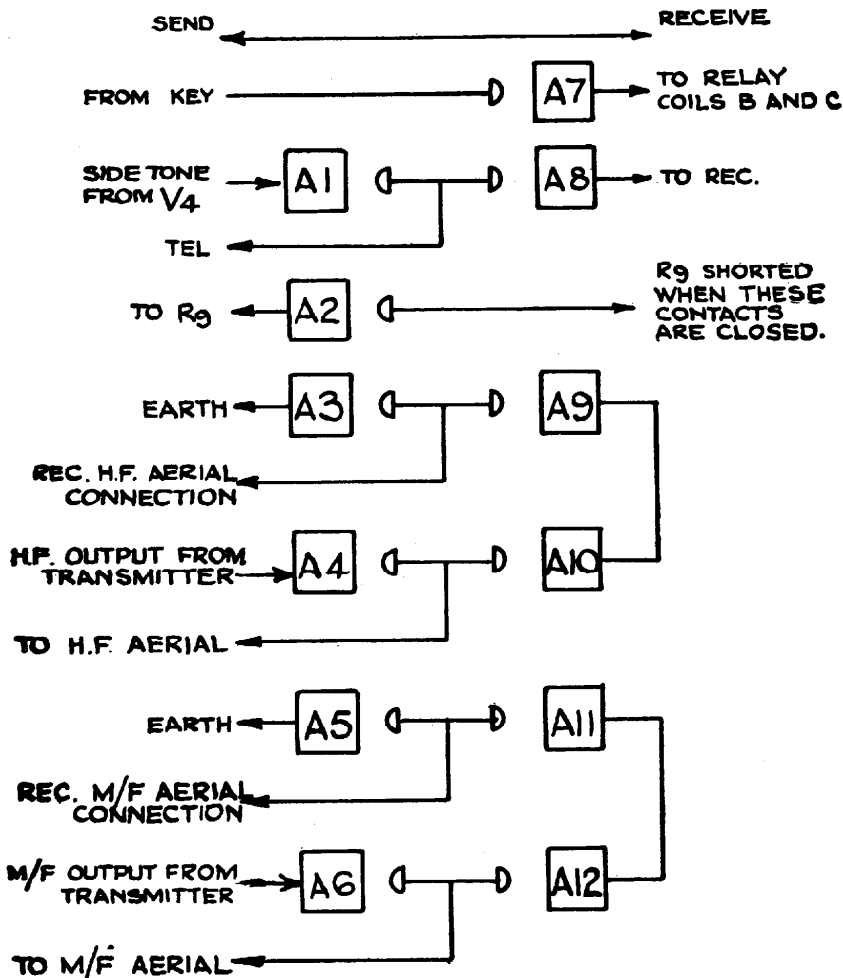

FIG. 3.—KEYING RELAY CONTACTS

Magnetic relay type 85 (keying relay)

30 Where mention has been made in the foregoing description of a relay in connection with keying and sidetone, it has referred to the magnetic relay type 85. This is a multi-contact relay with a row of moving contacts which move from side to side during keying to complete circuits through two rows of fixed contacts known respectively as the SEND and the RECEIVE contacts. It will be seen from fig. 3 that when at SEND, in addition to short-circuiting R_9 through the contacts A_2 , and connecting the telephones to the output of the valve V_4 via A_1 , the relay completes aerial connections to the transmitter via A_4 or A_6 . The particular aerial connected depends upon the position of the frequency range switch or the aerial selector switch type J. Both aerial connections from the receiver are earthed at contacts A_3 and A_5 .

31. On moving to RECEIVE the relay removes the short-circuit from R_9 , thus stopping oscillation, and connects the telephones and the aerial in use to the receiver.

Action of relay

32. The relay is operated by the 6-volt supply from the L.T. generator and is common to all versions of the transmitter. It can operate at a speed equivalent to more than 25 words a minute.

33. The relay incorporates three coils A, B, and C. The coil A is in circuit so long as the transmitter is switched on, that is, with the master-switch S_5 at any of the positions STD.BI, TUNE, C.W., M.C.W. or R/T. With S_5 in the STD.BI position the coil A only is energized and holds the relay in the RECEIVE position. The key is not in circuit. The coils can be seen in fig. 4, 5 and 6.

34. When the switch S_5 is in the TUNE, C.W., M.C.W., or R/T position the key is switched into circuit. Depression of the key energizes both B and C coils of the relay, the connection of the winding B being so arranged that its field neutralizes the field due to the holding coil A. At the instant when the nett field resulting from both coil A and coil B is zero the relay commences to move under the combined action of the spring contacts and coil C. The auxiliary contacts of the relay open, thus cutting off the current through the coil B. This sudden cessation of current in coil B causes a transient condition in the coil A which instantly reduces its current to zero. Thereafter the field of coil A is re-established, but not fully until after the elapse of a period considerably greater than the transit time of the relay. As coil C is energised simultaneously with coil B when the key is pressed, it follows that the relay motion initiated by coil B will be completed by the attraction of coil C.

35. When the key is released the relay returns rapidly to the RECEIVE position since the field of coil A is already re-established, and the current through coil C ceases as soon as the key contacts open.

Transmitters T.1154C, F, H, K, M

36. A complete circuit diagram of a transmitter providing C.W., M.C.W., and R/T communication on four frequency ranges (T.1154C, F, H, K, and M) is given in fig. 4. The transmitter master switch S_5 consists of six sections, identified on the diagram with the letters F, G, H, J, L, and M. In the OFF position of this switch, both the rotary transformer power units are idle and the equipment is inoperative.

37. In the STD.BI position a circuit is completed for the aircraft 12 or 24-volt supply from contact 4 of the Jones plug D on the front of the transmitter, through switch section H of S_5 , back to contact 3 of plug D and thence to the L.T. power unit. It will be seen that the circuit through switch section H is made in all positions of S_5 except OFF.

38. The 6-volt output of the L.T. power unit is brought into the transmitter at contact 6 of plug D and divides as follows:—

- (i) To coil A of the magnetic relay type 85, which goes over to RECEIVE.
- (ii) To heaters of V_1 and V_4 and to the filaments of V_2 , V_3 . Resistances R_{30} , R_{31} are included in the filament circuit of the P.A. valves to reduce the current they take when the transmitter is at STD.BI. In some transmitters a single .75-ohm resistance is used in place of R_{30} and R_{31} .
- (iii) To contact 3 of Socket A for supply to the receiver.

In the TUNE position of S_5 the following processes occur:—

- (iv) Limiting resistances R_{30} , R_{31} are short-circuited by sections F and G.
- (v) The 6-volt supply is switched by sections F and G as follows:—
 - (a) To contact 13 of plug E, whence it is taken *via* the aerial selector switch type J (provided this is in one of the positions other than D/F or EARTH), back to contact 14 of plug E and thence via contact 8 of plug D to the starting relay of the H.T. power unit. The 1,200-volt output of this power unit is supplied to the transmitter at plug C.
 - (b) The 6-volt circuit is also taken from contact 13 of plug E, *via* relay coil B, and relay contact A_7 to contact 13 of plug B, but no current flows while the key is up. It will be seen that while the keying relay A/12 is at RECEIVE, relay coils B and C are short-circuited by relay contacts A_7 .

39. When the key is pressed the 6-volt circuit through relay coil B is completed to earth via the key and as explained in para. 34 the flux from coil A, which has been holding the relay at RECEIVE, is neutralised, so that the relay begins to move under the pressure of the spring contacts. As soon as it does so relay contact A_7 breaks and the 6-volt circuit is diverted through coil C, holding the relay over at SEND. Relay contacts A_2 now short-circuit R_9 through pin 14 of plug B so that

the bias is removed from the control grids. The telephones are connected to the output of V_4 , via contact 16 of plug B, relay contact A_1 and section M of S_5 , enabling the operator to hear the sidetone note. V_4 is in an oscillating condition the whole time the master switch is at TUNE, since its grid is returned to the filament end of R_9 .

40. It will be noted that the total H.T. current is still flowing through R_{10} ; the suppressor grids of the P.A. valves are connected through HFC_3 and switch section L to the end of R_{10} which is negative with respect to the end to which the control grids are connected via S_5J , and so a bias on the suppressor grids is maintained.

41. When the master switch is turned to c.w. the suppressor grids are connected via S_5L to the junction of R_7 and R_9 , whence they receive a positive bias, and R_{10} is short-circuited by S_5J .

42. On turning the master switch to m.c.w., section L of S_5 applies the A.F. oscillations of V_4 , via C_8 , to the suppressor grids of V_2 and V_3 . The short-circuit is removed from R_{10} by switch section J so that the negative bias is re-established.

43. Similar conditions obtain on R/T, except that section J of S_5 disconnects the condenser C_7 between anode and grid of V_4 so that the valve ceases to oscillate and acts as an amplifier, and at the same time the microphone (or output of the external amplifier) is connected to the primary of T_1 via section L.

44. With S_5 at R/T the key is still in circuit and must be depressed for transmission to take place; alternatively a shorting switch connected across the key can be installed in a convenient position for the pilot. The key must be released, or the switch opened, to allow the keying relay to return to RECEIVE before reception can take place. The power output (when fully modulated) is approximately $\frac{1}{2}$ of that on C.W. This applies to both R/T and M.C.W. and is the result of suppressor modulation, *not* of class C operation.

Frequency range switch

45. The ganged switches S_{11} , S_{2c} select the appropriate M.O. and P.A. tuning circuits for the different frequency ranges. The same coils and condensers are used for both BLUE ranges, so section N of S_1 short-circuits a portion of L_1 on Range 1 and S_{2c} connects L_{4c} in parallel with the P.A. coil L_4 to reduce the total inductance. On Range 2 the whole of L_1 is used and L_{4c} is switched out of circuit.

46. Resistances R_1 , R_2 are connected between H.T. + and earth on Range 4 (M.F.) by section O of S_1 in order to provide a parallel H.T. load and so limit the anode voltage on V_1 , as the efficiency of the M.O. stage is considerably higher on the medium frequencies. In some transmitters a single vitreous resistance is used in place of the two resistors.

47. It will be seen that on Range 4 the anodes of V_2 , V_3 are connected by S_{2c} to the anode tapping switch S_6 , which enables any one of seventeen points of connection to the P.A. coil L_4 to be selected. On this range also S_{2c} connects across the P.A. feed meter, M_1 , the system of variable shunts provided by resistances R_{19} to R_{23} .

Variable meter shunt

48. This transmitter is set up by adjusting the output circuit until the meter M_1 reads to a fixed point on its scale. The actual input represented by this reading is higher than is desirable on the M/F range, and consequently on these frequencies the meter is made to read higher by means of additional shunts, so that when its reading is reduced to the prescribed point on the scale, the input is in fact lower than it appears to be. In this way the value of R.F. voltage on the medium frequencies is kept within limits by the operator as part of his tuning procedure. The R.F. voltage depends upon the inductance in the aerial circuit and the current through it. The object of the shunt is to prevent the voltage developed exceeding 6,000, above which the insulation of fairleads, cables, etc., might begin to break down.

49. The value of shunt is selected by the switch S_8 , which is ganged with the M.F. aerial coarse tuning switch S_7 , and so arranged that the shunt resistance is increased concurrently with an increase in aerial inductance by switching in resistances R_{20} to R_{23} as S_7 is moved from tap 10 to tap 17. These are added in series with R_{19} , which is across the meter in all positions of S_7 . The full scale deflection of the meter for the different values of aerial tap is shown in the following table:—

<i>Aerial tap</i>	<i>Full scale deflection (mA)</i>
1-9	300
10-11	255
12-13	210
14-15	165
16-17	120

C ₁₉ C ₂ C ₁₈	C ₄ C ₂₆	C ₁₇ C ₂₇	C ₁₀ C ₁₁	C ₇ C ₈	C ₅	C ₆ C ₂₁	C ₁₂	C ₁₃ C ₉	C ₁₄	C ₃₂	C ₂₂ -C ₂₅ C ₂₀	C ₁₅	C ₃₀ C ₃₁ C ₁₆					
R ₃	R ₅ R ₆	R ₂₈	R ₂₇	R ₁₃ R ₁	R ₂₆ R ₁₄ R ₁₅	R ₂	R ₁₁	R ₂₉ R ₂₄ R ₂₅	R ₁₂ R ₃₀	R ₃₁	R ₁₀	R ₉ R ₇	R ₈ R ₄	R ₁₆ -R ₁₈	R ₂₀ -R ₂₃	R ₁₉	R ₄₁	
H.F.C.2	L ₁	L.F.C.3	L ₂ L ₁	L ₃	F ₁	V ₄	L.F.C.2	V ₁	H.F.C.3	H.F.C.1	S ₅ V ₂	V ₃	L ₆ L ₄	S ₃ S ₆ S ₈	L ₄ C	S ₄	REL A/12	L ₅

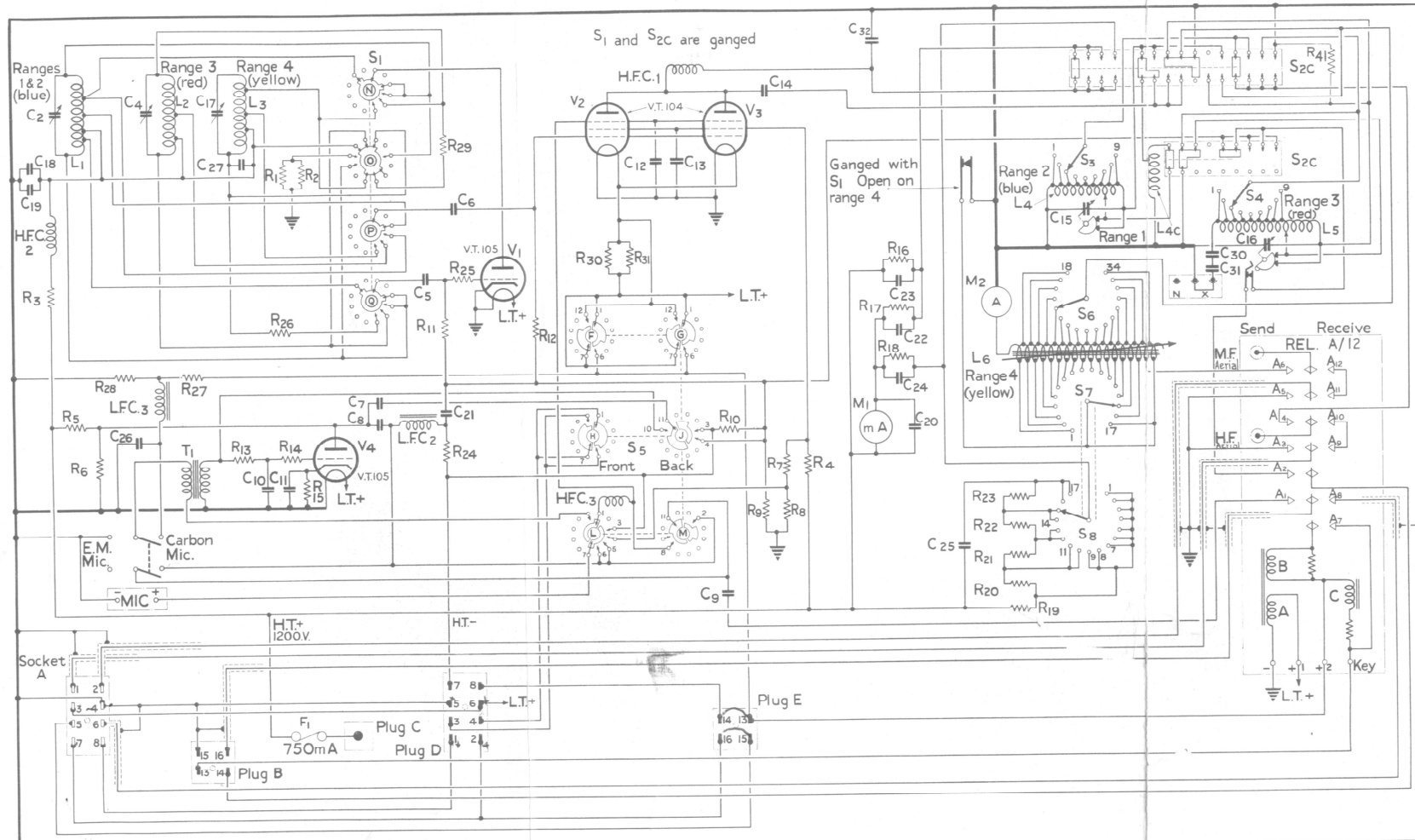

Note: S₁ and S₅ shown in extreme anti-clockwise position
Socket & plugs as viewed from front of transmitter.

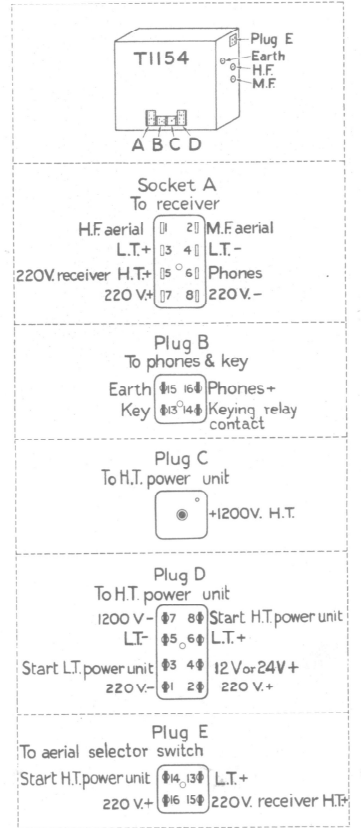
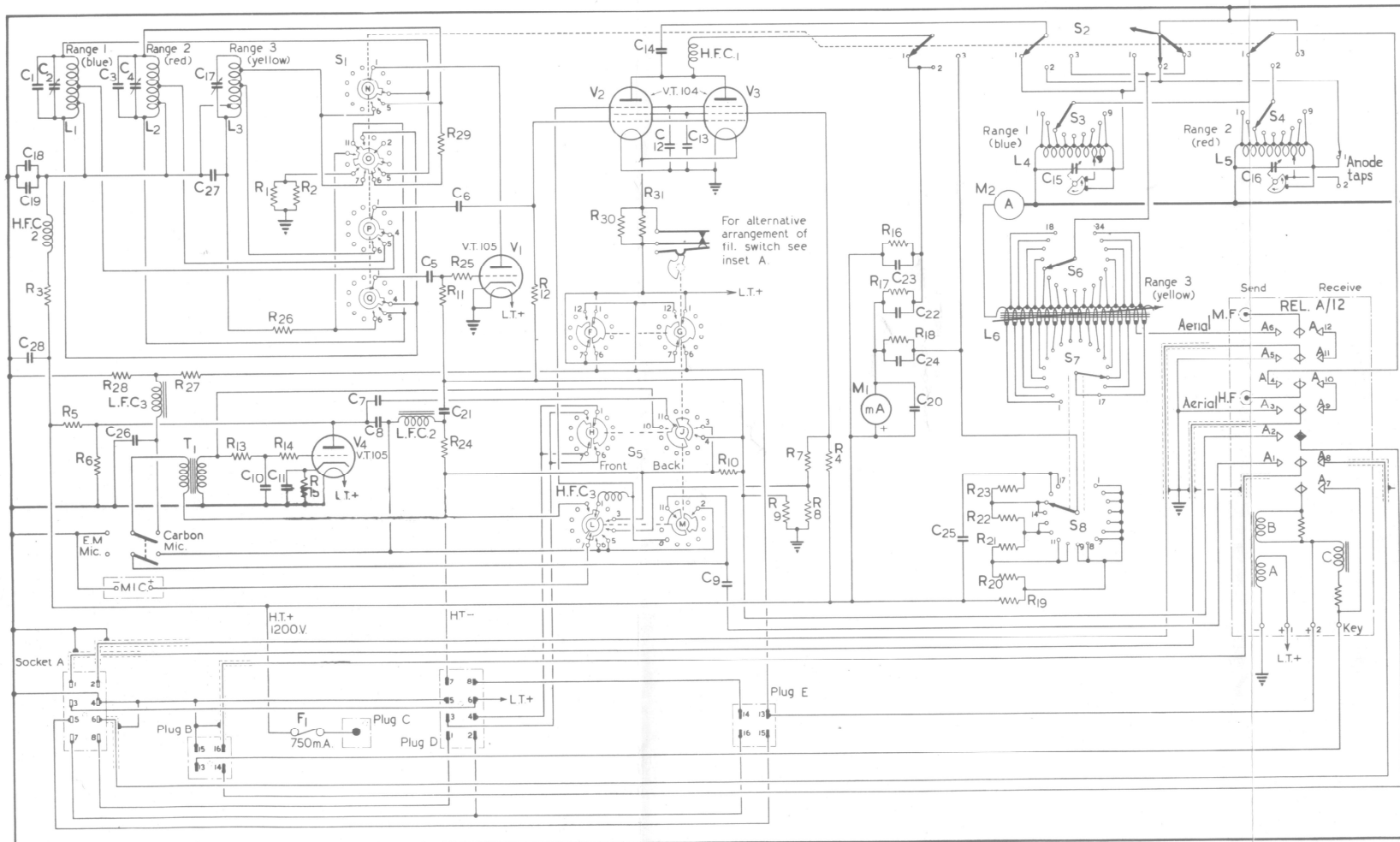

FIG. 4

CIRCUIT OF T. 1154C, F, H, K. & M

FIG. 4

C18 C19	C1 C28	C4 C26	C7 C27	C10 C11	C7 C8	C5 C6	C21 C20	C14 C13	C9	C22-C24 C20	C25	C15	C16
R3	R5 R6 R28	R27	R13	R1 R2 R26 R14 R15	R29 R11 R25	R12	R30 R31	R10	R7-R9	R4	R16-R18	R19-R23	
L1 HFC2	L2 LFC3	T1	L3	F1	V4	S1	LFC2	V1	HFC3	S5	V3	L4 S3 S7 S2 L6 S6 S8	S4 L5 REL. A/12



Note. S1 and S5 shown in extreme anti-clockwise position. Socket & plugs as viewed from front of transmitter

CIRCUIT OF T1154, T1154B, D, J, AND N

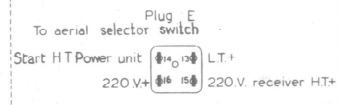
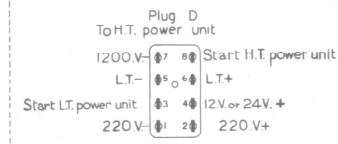
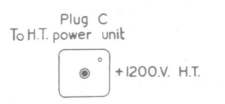
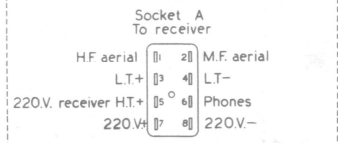
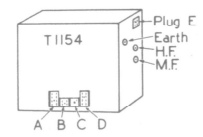
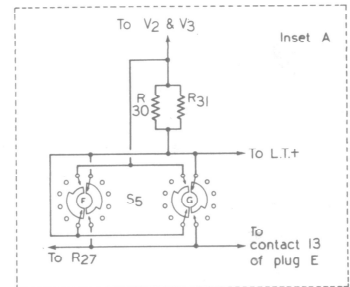
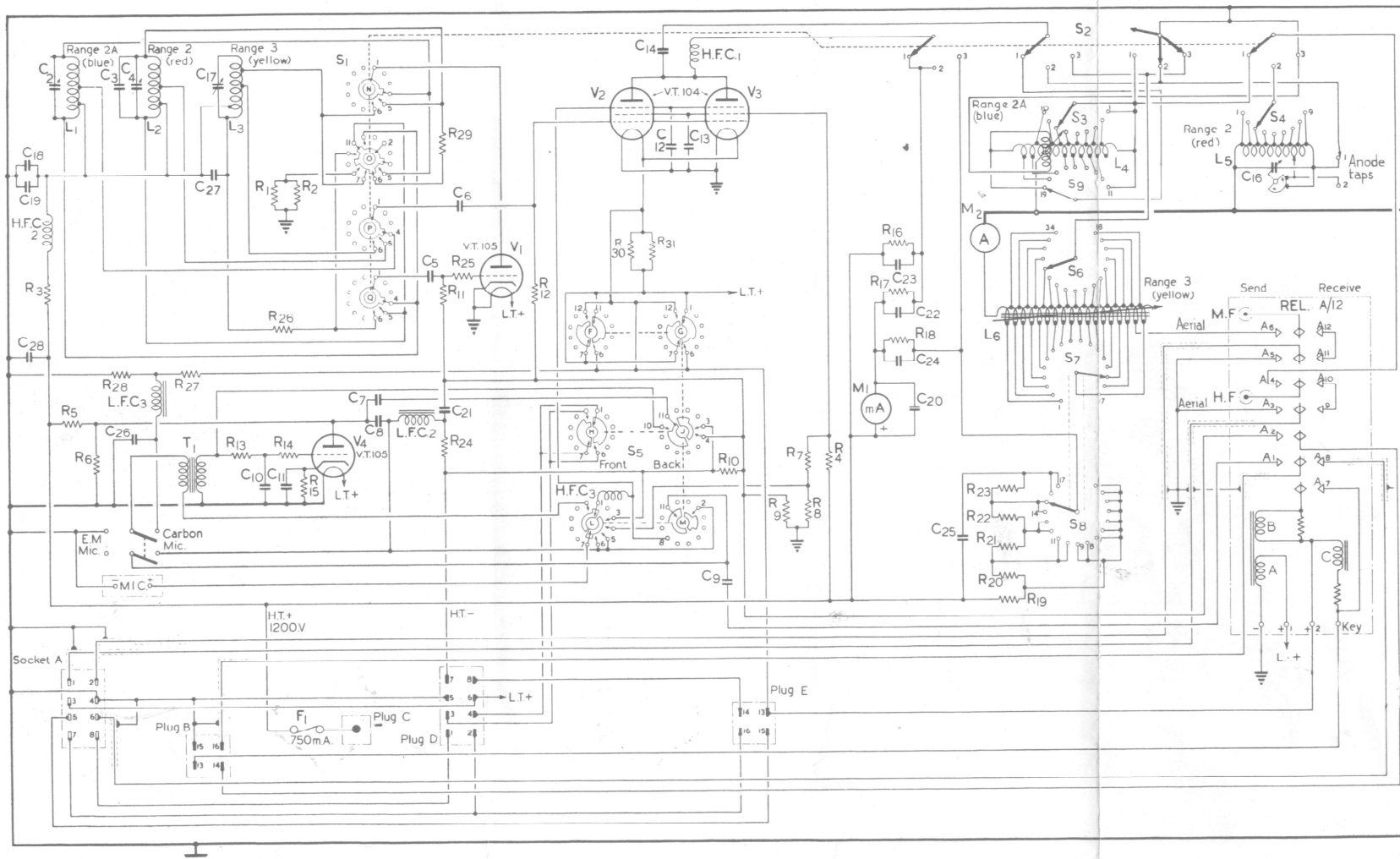

FIG. 5

FIG. 5

C18 C19	C2 C26	C4 C27	C10 C11	C7 C8	C5 C6 C21	C12 C13	C9	C22-C24 C20	C25	C16									
R3	R5	R6	R28	R27	R13	R1	R2	R29	R11	R25	R12	R30	R31	R10	R7-R9	R4	R16-R18	R19-R23	
L1 HFC2	L2 LFC3	T1	L3	F1	V4	S1	LFC2	V1	V2	HFC1	V3	L4	S3	S8	S2	S7	S9	S4	REL A/12



Note. S₁ and S₅ shown in extreme anti-clockwise position. Socket & plugs as viewed from front of transmitter.

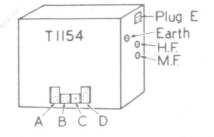

Socket A
To receiver
H.F. aerial 1 2 M.F. aerial 3 4
LT+ 5 6 LT- 7 8
220V. receiver HT+ 9 10 Phones 11 12
220V- 13 14 220V- 15 16

Plug B
To phones & key
Earth 15 16 Phones + 17 18
Key 19 20 Keying relay contact 21 22

Plug C
To H.T. power unit
+1200V. H.T. 1 2

Plug D
To H.T. power unit
1200V. 3 4 Start H.T. power unit
LT- 5 6 LT+ 7 8
Start LT. power unit 9 10 12V or 24V. + 11 12
220V- 13 14 220V+ 15 16

Plug E
To aerial selector switch
Start HT Power unit 17 18 LT+ 19 20
220V- 21 22 220V. receiver HT+ 23 24

FIG. 6

CIRCUIT OF T1154L

FIG. 6

50. On the H.F. ranges R_{10} is the meter shunt and the full scale deflection of M_1 is 300 mA. Resistances R_{17} and R_{18} are in series with the meter on the H.F. and M.F. ranges respectively.

51. An aerial ammeter M_2 is in circuit on the YELLOW range. This meter is seen on the front panel in fig. 1. An external aerial ammeter (Stores Ref. 10A/12227) is used on the H.F. ranges in all aircraft installations.

Tuning and aerial matching devices

52. It will be seen in fig. 4 that the BLUE range P.A. tuning condenser, C_{15} , and the RED range P.A. tuning condenser C_{16} have a commutator arrangement which short-circuits part of the coils concerned during 180° rotation of the condenser vanes and permits the whole coil to be tuned during the remaining 180° . This greatly increases the tuning range available and enables resonant conditions to be obtained with widely differing aerial systems.

53. A cam on C_{16} breaks two switch contacts at the moment the commutator switch makes or breaks. These contacts are in series with the keying relay and so when they open have the same effect as if the key was momentarily raised. The cut-off bias developed across R_9 is therefore applied for an instant to the control grids of the valves and arcing of R.F. across the commutator switch contacts is avoided.

54. Two further switch contacts, ganged with S_1 , are opened only when S_1 is in the Range 4 position, and short-circuit the YELLOW range coil L_6 except when it is actually in use, thus avoiding absorption effects on other frequency ranges.

55. On the RED range (Range 3) a three-point reversible socket X-N is interpolated between the aerial coil L_5 and earth. Its purpose is to enable highly resistive or reactive aerals to be satisfactorily loaded. The normal position of the socket is with the arrow (on the panel) pointing to N. In the reverse position a condenser of $.0003 \mu F$ (that is, $C_{30} + C_{31}$) is connected between the aerial end of the circuit and earth. In fig. 4 the condensers are shown in circuit.

Transmitters T.1154, T.1154A, B, J, N

56. Transmitters of these types provide three frequency ranges as shown in Table 1. The circuit diagram in fig. 5 applies to this series except that no R/T facilities are provided in the T.1154A. On the RED range two anode tapping points are provided for the P.A. valves. For working into normal aircraft aerals connection is made to tap No. 1, but if the aerial is very short it will be necessary to use tap No. 2. This adjustment is made at the time of installation and does not require to be altered. On early transmitters in this series the P.A. filament resistances R_{30} , R_{31} (see para. 38 (ii)) were switched in and out of circuit by cam-operated contacts on S_5 . Later versions adopted the alternative arrangement shown inset in fig. 5. The frequency range switch S_2 , ganged with S_1 , consists of four sections worked by a common operating bar.

57. On the frequencies covered by Range 2 in this series trouble is not experienced with arcing at the commutator switch of C_{16} and the cam-operated contacts described in para. 53 are therefore omitted.

Transmitters T.1154D T.1154E

58. The transmitters T.1154D (R/T, C.W., and M.C.W.) and T.1154E (C.W. and M.C.W. only) differ from the T.1154 and T.1154A only in respect of the modified frequency coverage on Ranges 1 and 2 and in their application. They are used in multiple-channel transmitter mobile ground stations and are supplied with power from single-phase, 50 c/s mains through a rectifier type 26. As the transmitters are not interlocked with a receiver as in airborne installations, arrangements are made whereby the relay A/12 is held permanently to SEND.

59. The output from these transmitters is worked into either local or remote aerial systems. The remote system consists of a quarter-wave inclined aerial. The local system is, normally, a triatic supported array the arrangement of which provides for anchoring eight possible aerals. The circuit of the T.1154D is given in fig. 5. The circuit of the T.1154E is similar except that R/T is not provided.

Transmitter T.1154L

60. The transmitter T.1154L covers the (A.L.S.) frequency ranges shown in Table 1. A circuit diagram is given in fig. 6. On Range 2A the P.A. tuning coil is the variometer L_4 , with ten tapings for coarse aerial tuning selected by switch S_9 , and nine anode tapping points selected by S_9 . Otherwise the circuit is similar to the other transmitters having three frequency ranges.

Aerial selector switch, type J

61. The plugs marked H.F. and M.F. on the side of transmitter are connected by sockets and flexible leads to plugs similarly labelled on the aerial selector switch type J. The leads from the aeriels themselves terminate in sockets which engage with the plugs on the switch marked FIXED AE. and TRAILING AE. It will be seen from fig. 8 that the switch has two sets of contacts, and five positions, marked NORMAL, H.F. ON TRAILING, M.F. ON FIXED, D/F, and EARTH. When the switch is at M.F. ON FIXED an external condenser, type 764 ($80 \mu\mu\text{F}$) is connected by the main contacts in parallel with the aerial tuning circuit to compensate for the smaller capacity of the fixed as compared with the trailing aerial. In the D/F position the switch connects an internal $25 \mu\mu\text{F}$ condenser in series with the fixed aerial, which is used for reception in these circumstances, and the pick-up of the long fixed aerial is brought approximately into line with that of the loop so that the two signals are about equal, thus getting the best heart-shape diagram for D/F.

62. Leads from pins 13 and 14 on transmitter plug E are taken via sockets to the switch. These carry the 6.3 volt supply for energising the H.T. power unit starting relay and it will be seen that this circuit is broken by the auxiliary contacts in the D/F and EARTH positions of the switch. With the switch at EARTH, both aeriels are directly earthed at the switch and the connections to the transmitter and receiver are broken.

63. The 220-volt receiver H.T. supply also passes through the switch between contacts 15 and 16 of transmitter plug E. It is arranged that the receiver H.T. is interrupted if the receiver master switch is turned to one of the D/F positions while the type J switch is in any position other than D/F, as in all positions except D/F and EARTH the transmitter can be operated, and the visual indicator might be burned out by induction, or its needles damaged.

64. All the plug and socket connections to the switch are shown in the installation diagram, fig. 21, Chap. 2.

The aerial selector plug board

65. On a limited number of early installations, an aerial selector plug board is fitted instead of the aerial switching unit, type J. The connections of the plug board are shown in fig. 7. Changing over the sockets on the centre pair of plugs makes it possible to obtain M/F transmission on fixed aerial or H/F transmission on trailing aerial should either aerial become defective.

66. When the aerial plug board is used the socket, type 175 (Stores Ref. 10H/425), which engages with plug E on the transmitter, must have its pins 13 and 14 and pins 15 and 16 short-circuited in order to complete the input circuit to the H.T. power unit.

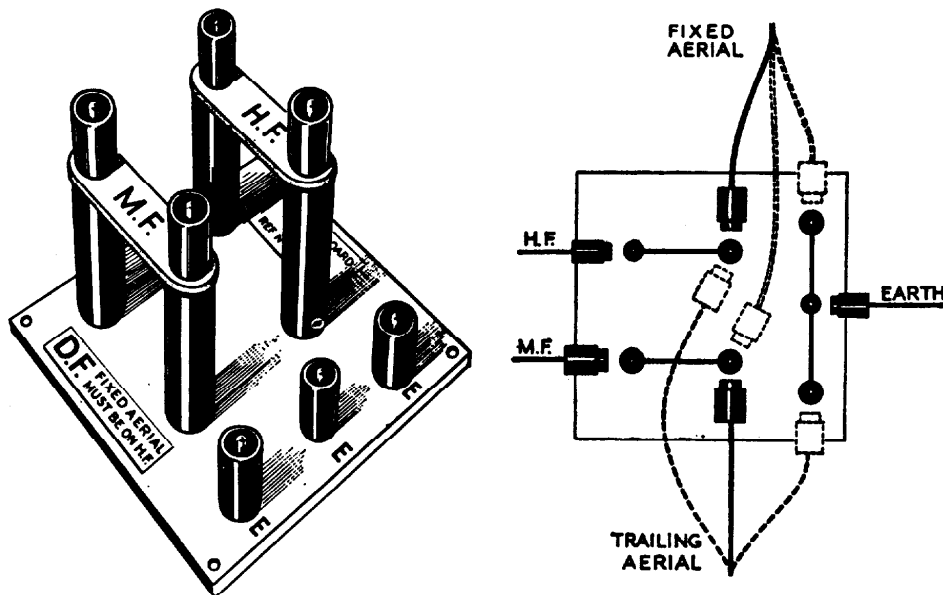
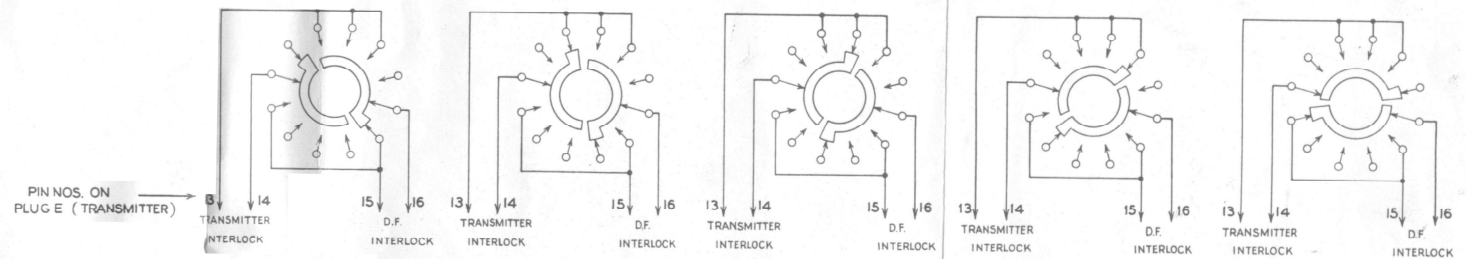
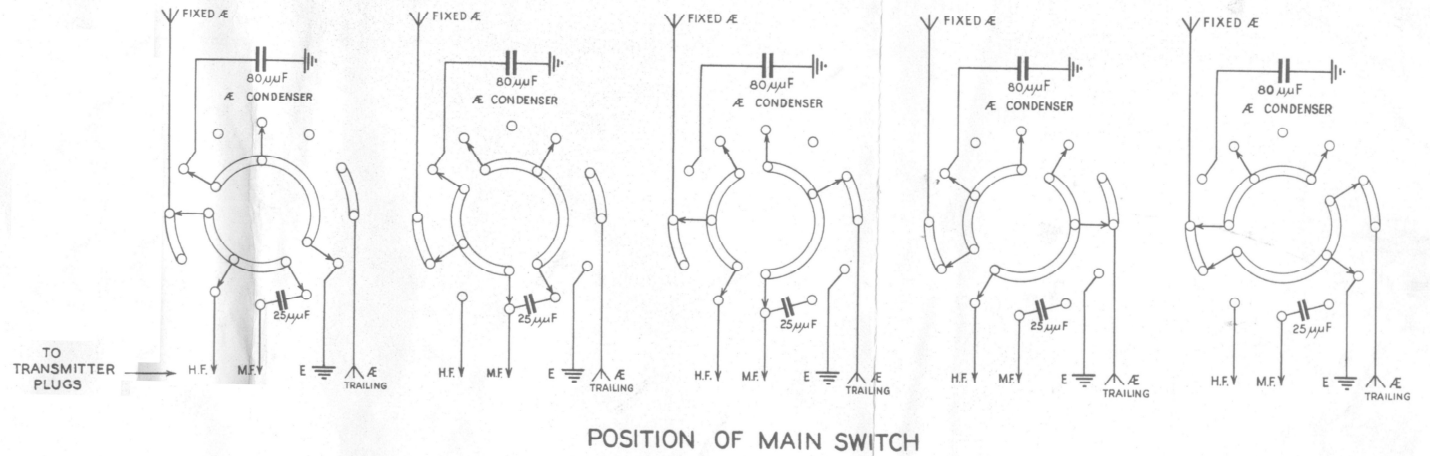
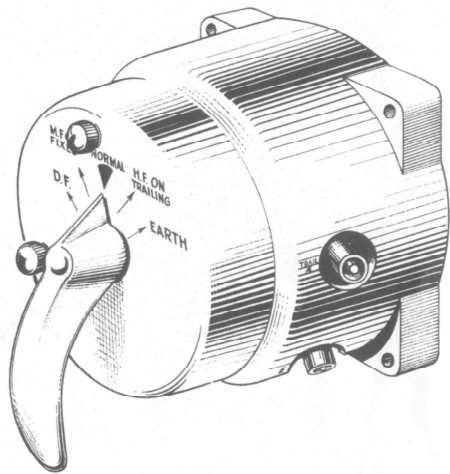

FIG. 7.—AERIAL PLUG BOARD

Power supply circuits

67. Although the power units are dealt with later in the chapter, two simplified diagrams, fig. 9 and 10, are included here to assist in tracing the switching circuits. The input from the aircraft,



AERIAL SWITCHING UNIT, Type J
THEORETICAL CONNEXIONS

D.F.
POSITION 1

MAIN SWITCH
FIXED $\text{A}\epsilon$ TO H.F. & M.F.

AUXILIARY SWITCH
TRANSMITTER INTERLOCK
OPEN CIRCUIT
D.F. INTERLOCK CLOSED CIRCUIT

M.F. ON FIXED
POSITION 2

MAIN SWITCH
FIXED $\text{A}\epsilon$ TO M.F. & $\text{A}\epsilon$ LOADING CONDENSER

AUXILIARY SWITCH
TRANSMITTER INTERLOCK
CLOSED CIRCUIT
D.F. INTERLOCK OPEN CIRCUIT

NORMAL
POSITION 3

MAIN SWITCH
FIXED $\text{A}\epsilon$ TO H.F.
TRAILING $\text{A}\epsilon$ TO M.F.

AUXILIARY SWITCH
TRANSMITTER INTERLOCK
CLOSED CIRCUIT
D.F. INTERLOCK OPEN CIRCUIT

H.F. ON TRAILING
POSITION 4

MAIN SWITCH
TRAILING $\text{A}\epsilon$ TO H.F.

AUXILIARY SWITCH
TRANSMITTER INTERLOCK
CLOSED CIRCUIT
D.F. INTERLOCK OPEN CIRCUIT

EARTH
POSITION 5

MAIN SWITCH
FIXED & TRAILING $\text{A}\epsilon$ 'S
TO EARTH

AUXILIARY SWITCH
TRANSMITTER INTERLOCK
OPEN CIRCUIT
D.F. INTERLOCK CLOSED CIRCUIT

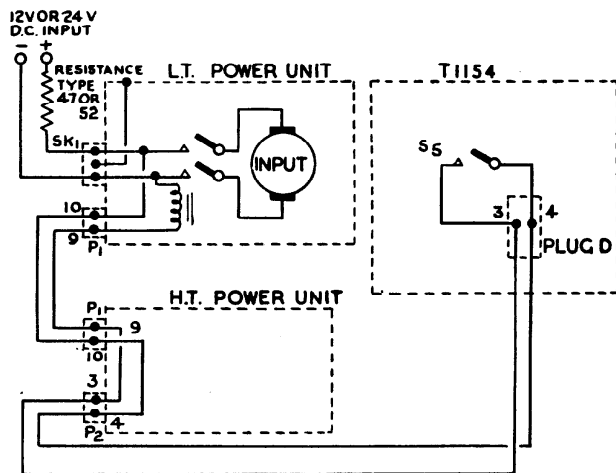

FIG. 9.—INPUT AND STARTING CIRCUIT, L.T. POWER UNIT

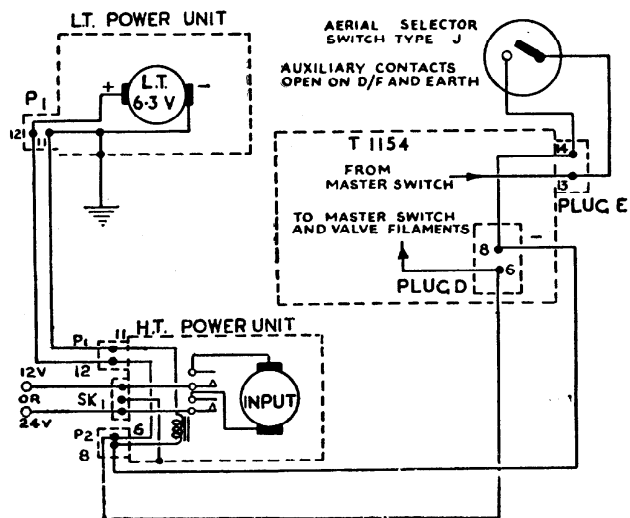
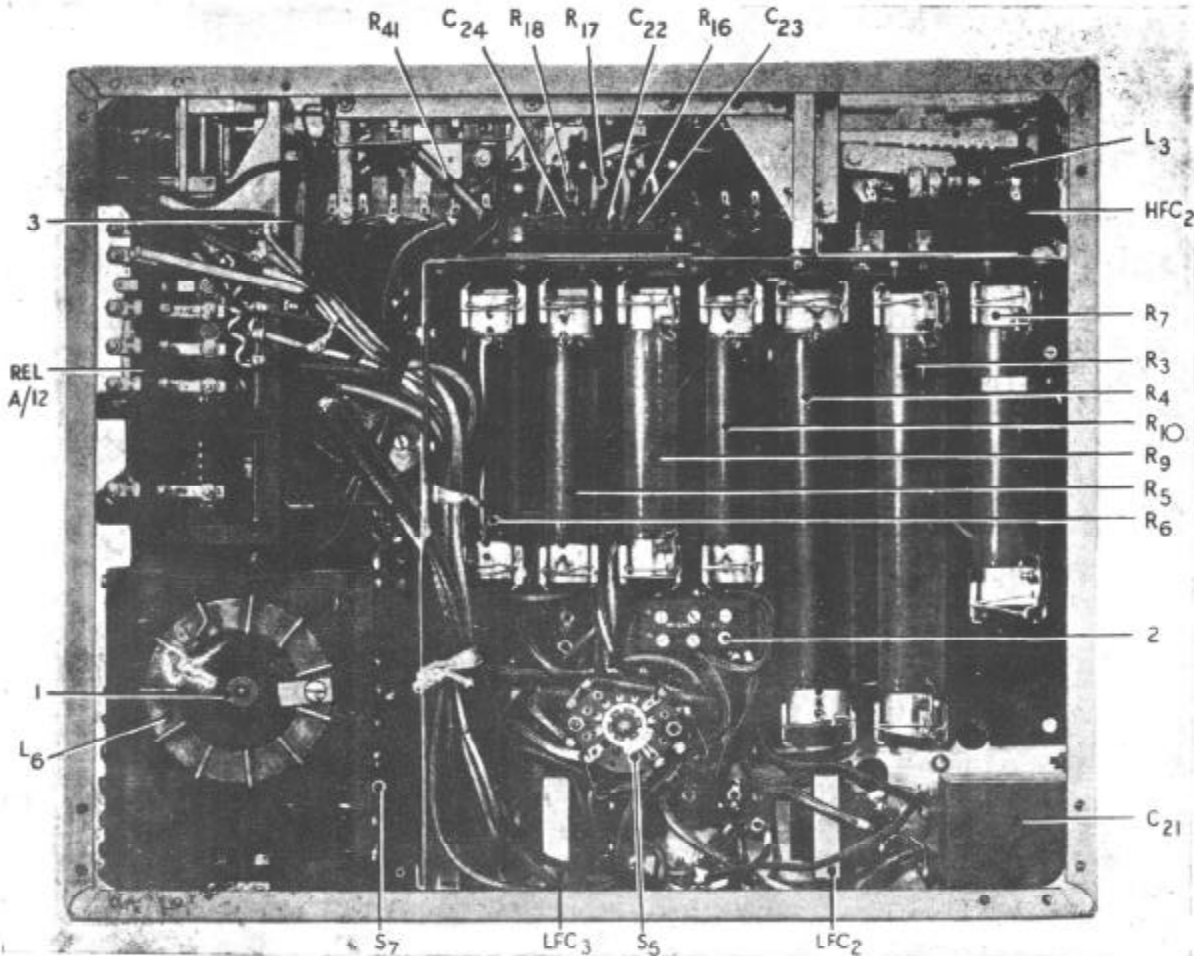

FIG. 10.—INPUT AND STARTING CIRCUIT, H.T. POWER UNIT

electrical system is taken through plug and socket connections on the L.T. and H.T. power units to the transmitter, and after passing through the master switch therein is returned by the same route to the starting relay of the L.T. power unit (see fig. 9). The 6.3 volt output of the machine is taken *via* plugs and sockets on the H.T. power unit to the transmitter, whence a circuit in parallel with the valve filaments passes to the aerial selector switch type J, and back through the transmitter again to the H.T. power unit, where it is applied to the starting relay (see fig. 10). Starting of the H.T. power unit is therefore dependent upon the L.T. supply being established.

CONSTRUCTIONAL DETAILS

68. A view of a transmitter T.1154M is given in fig. 1. The cover over the valve compartment has been removed, showing the sidetone and modulator valve, V_4 , on the left, and one of the P.A. valves, V_3 , on the right. In transmitters T.1154, T.1154A, B, D, E, J, and N, the terminals for the alternative anode taps (see para. 56) are located at the top right-hand side of the valve compartment. The master oscillator valve, V_1 , is behind V_4 . This transmitter has the Uni-click mechanism for setting up to pre-set frequencies. One of the knobs for selecting the desired click-stop is indicated at (1). If a knob is turned to the FREE position none of the click-stops on the control concerned is operative.



- | | | |
|--|---|----------------------------|
| 1. Sliding core for fine tuning of L_4 | 2. Reversible plate for operation with carbon or E.M. microphones | 3. Keying relay resistance |
|--|---|----------------------------|

FIG. 11.—REAR VIEW OF T.1154M

69. On the H.F. ranges a pre-set frequency can be varied by plus or minus 0.1 per cent. by means of the vernier controls for the M.O. condensers seen at (2) and (3).

70. Seven click-stops are provided on each M.O. range, lettered as follows. Ranges 1 and 2, A to G; Range 3, J to Q; Range 4, S to Y. Only on Ranges 1, 2, and 3, are the P.A. dials click-stopped, the lettering being the same as on the M.O. dials.

71. The various controls in the illustration are given the same references as are used in the circuit diagram, fig. 4, and their functions have already been dealt with in the general circuit description. Socket A and plugs B, C, and D at the front of the transmitter are indicated by their reference letters. The Jones plugs and sockets which engage therewith are kept in position by the retaining bar (4).

72. The sockets for the input from a carbon microphone or from an intercommunication amplifier are shown at (5). At (6) is seen the reversible plug which provides for the connection of condensers C_{30} and C_{31} between L_3 and earth as described in para. 55. When the plug is inserted as shown, with the letter N against the arrow marked on the panel, the condensers are out of circuit.

73. The fuse F_1 is of the glass tubular type and is rated at 750mA. Four spare fuses are carried in clips behind the cover of the valve compartment.

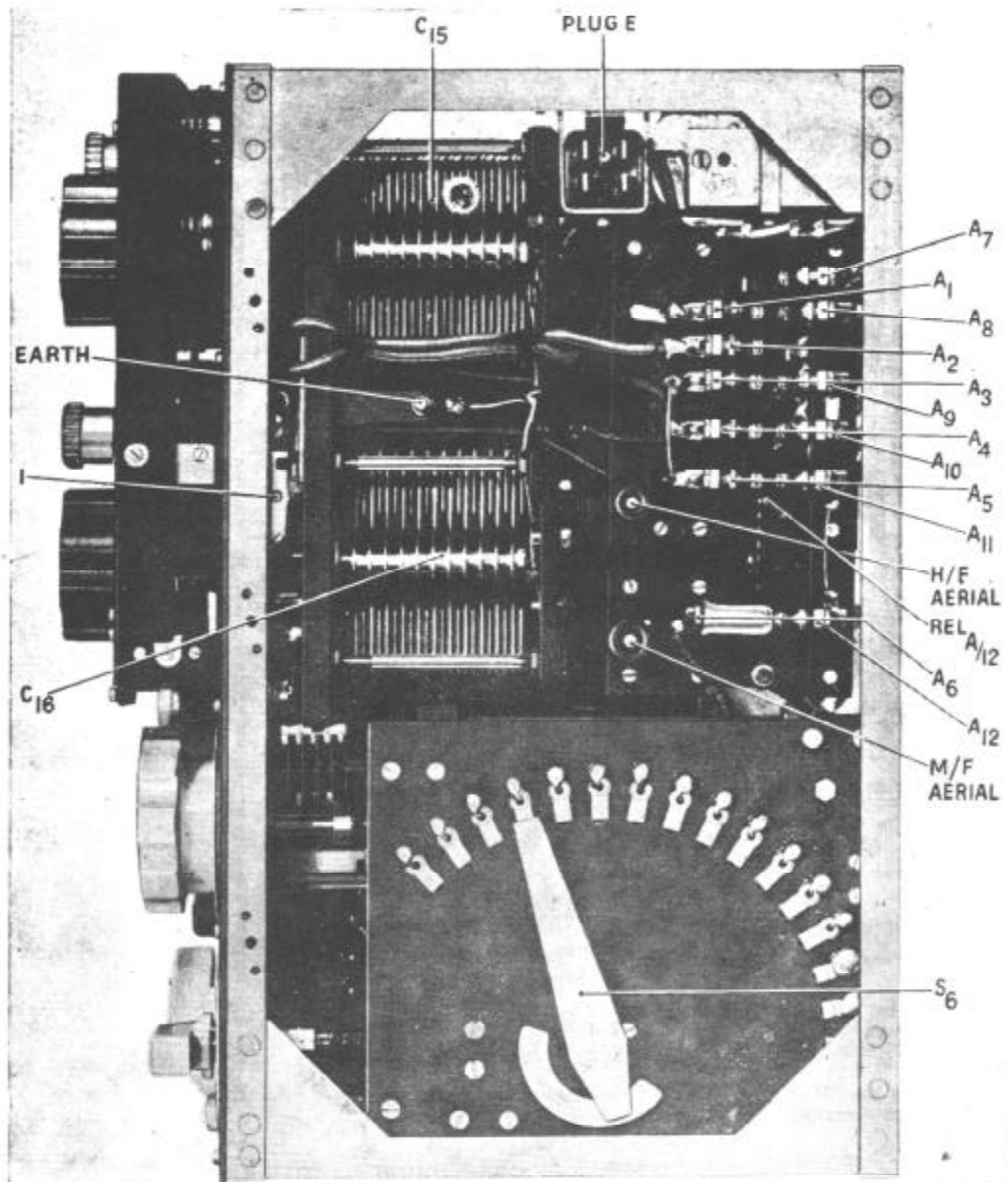

1. Contacts of cam-operated switch on C_{14}

FIG. 12.—T.1154M, KEYING RELAY AND OUTPUT END

74. Cylindrical screens (7) are fitted over the bases of both P.A. valves. The anode connectors to the P.A. valves are mounted on vertical spring-loaded rods (8). These rods pivot so that the connections can be swung clear of the top caps when the valves have to be removed. One of the connectors can be seen in place on the top cap of V_2 at (2) in the top view of the transmitter, fig. 14. The meter M_2 is the aerial ammeter and is in circuit on Range 4 (M/F) only.

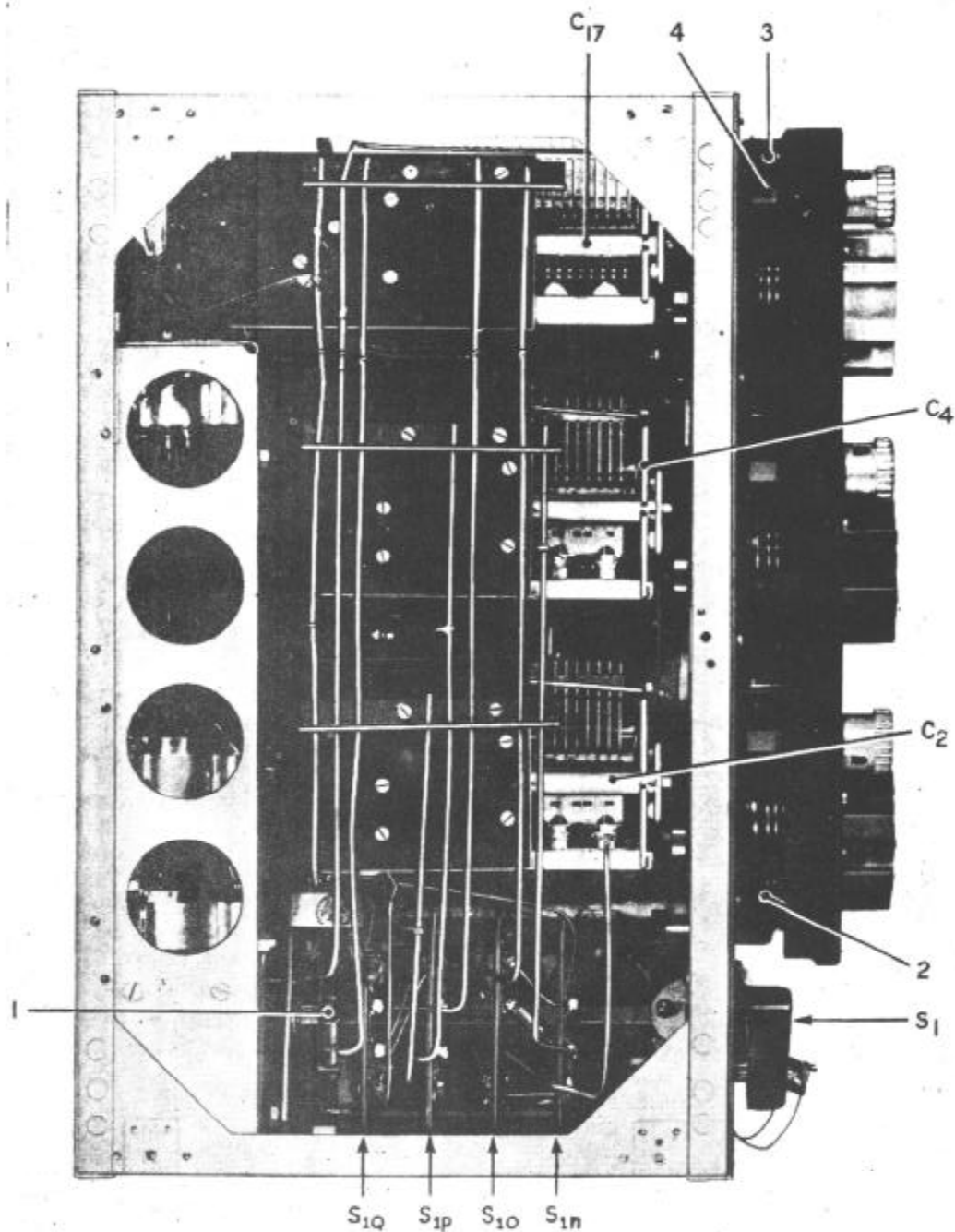

1. Operating link of frequency range switch

2. Click-rings of click-stop mechanism

3. Ends of click-stop selector levers

4. Click-stop selector cam

FIG. 13.—T.1154M, M.O. AND FREQUENCY SWITCH END

75. A rear view of the transmitter, removed from its case, is given in fig. 11. Some of the contacts of the frequency range switch, S_{2C} , can be seen at the top centre of the illustration behind the meter resistances R_{16} , R_{17} , R_{18} (see para. 50). The moving contacts of this switch are mounted on a bar that slides horizontally. The view of the relay A/12 shows the RECEIVE contacts. One of the two 1.5 ohm vitreous resistances associated with this relay is indicated by (3). Under the relay assembly is the Range 4 tuning coil, L_4 , the sliding iron-dust core of which is seen at (1). Some of the contacts of the Range 4 aerial tapping switch S_7 , can be seen on the right of the casing enclosing the coil.

76. The reversible plate for adapting the transmitter to be used with carbon or electro-magnetic microphones is shown at (2). It is reversed by removing the six fixing screws, and replacing it so that the engraving for the required microphone type is showing.

77. Another view of the relay A/12, showing all moving and fixed contacts, is given in the end view of the transmitter, fig. 12. The contacts are labelled in conformity with fig. 3. The aerial and earth plugs and plug E for the interlock connection to the aerial selector switch type J are also shown. The cam-operated contacts on C₁₄ (see para. 53) can be seen at (1).

78. The other end view of the transmitter, fig. 13, shows the four wafers of the frequency range switch S₁. The operating link (1) of S₁, works the sliding switch S_{2c} at the top of the chassis through a system of cranks and rods. In this illustration some of the click rings of the click-stop mechanism are shown at (2). The ends of one set of the click-stop levers that engage with the rings to hold the dials in the selected positions are indicated by (3). A selector cam (see para. 91) is shown at (4). The vertical parallel wires in this illustration are connections between S₁ and the associated condensers and inductances for the four frequency ranges.

79. A view of the transmitter from the top is given in fig. 14. The whole of the switch S_{2c} is visible, together with one of the cranks (1) which operate it. An anode connector is shown in position on the top cap of the P.A. valve V₂ at (2). The view also shows the coil L_{4c} which is switched in parallel with L₄ to reduce the total P.A. tuning inductance on Range 1.

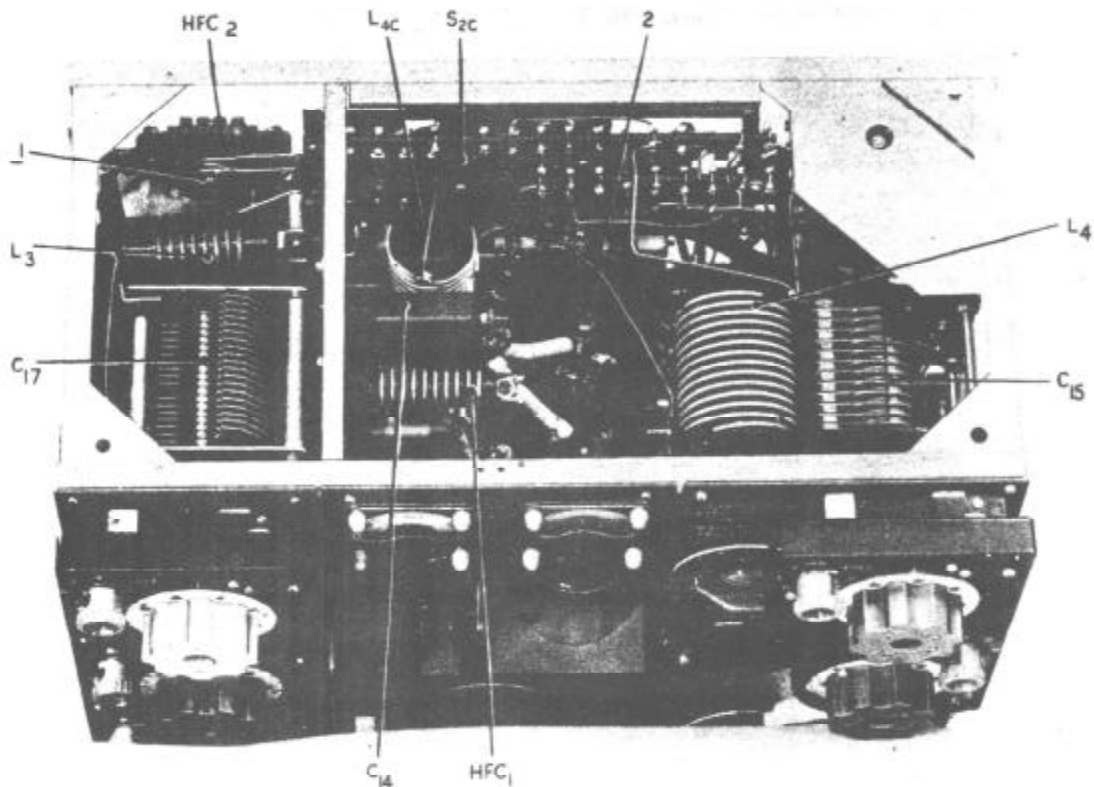

1. Operating crank for S_{2c}
2. Pivoted connector to P.A. valve anode cap

FIG. 14.—TOP VIEW OF T.1154M

80. In the underside view of the transmitter, fig. 15, the spring-loaded bar (1) carries the contact which short-circuits the Range 4 P.A. coil L_4 on the H.F. ranges. It is operated by a cam on S_7 , which in this view is in the M.F. position, the contacts being broken. The P.A. valve filament resistances R_{30} , R_{31} , which may be either vitreous or wire wound, are carried on the panel (2). The contacts of the anode and aerial tapping switches S_6 , S_7 , are rotated by gearing, part of which is seen at (3).

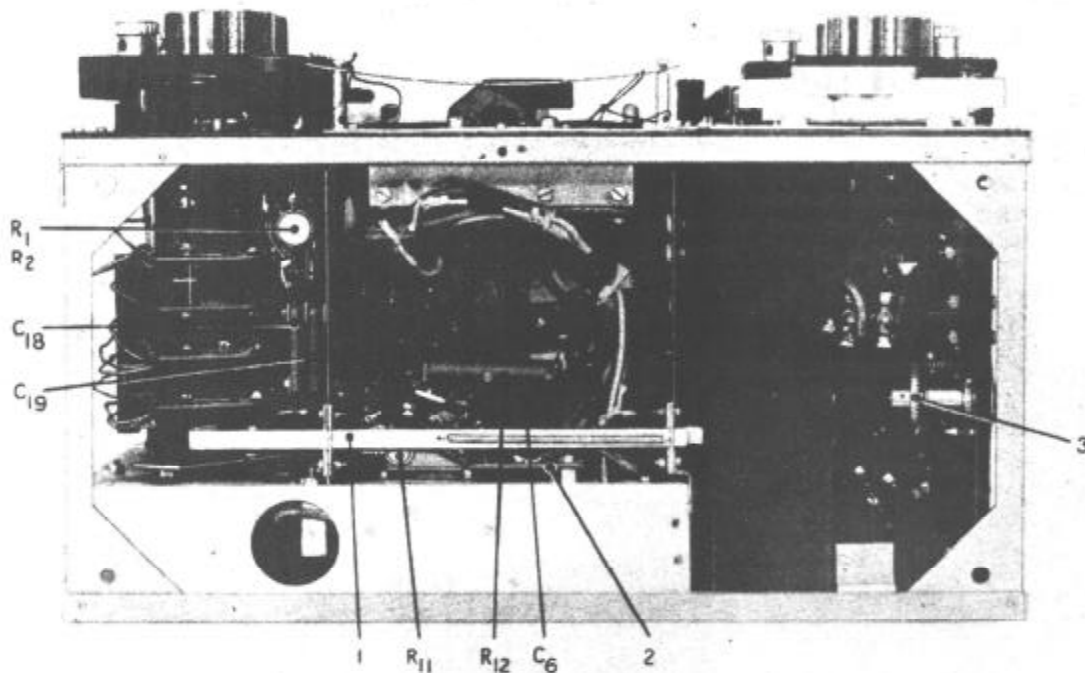

- | | | |
|--------------------------------------|--|---|
| 1. Short-circuiting bar for
L_4 | 2. Mounting for P.A. valve
filament resistances | 3. Bevel drive of M.F range
anode tapping switch |
|--------------------------------------|--|---|

FIG 15—UNDERSIDE VIEW OF T.1154M

81. A semi-circular commutator switch having two switch brushes is fitted to the spindles of the condensers C_{18} and C_{19} . This commutator switch is so arranged that the condenser completes one-half revolution with the brush contacts open and the other half revolution with the brush contacts closed. When the brush contacts are closed, part of the inductance L_4 or L_5 is short-circuited. The angular setting of the commutator permits the condenser to sweep from maximum to minimum capacitance with the commutator brush contacts open. In the same manner the condenser sweeps from minimum to maximum capacitance with the contacts closed. As the opening and closing of the commutator contacts alters the inductance value of L_4 or L_5 , a greater range of tuning is achieved. This affords the tuning margin for coupling to a diversity of aerials.

82. The drive (M.O.) and output (P.A.) units of the transmitter are removable as individual assemblies. The drive unit includes the three M.O. tuning condensers and their click-stop mechanisms, the associated inductances, and the frequency range switch, S_1 . The output unit consists of a magnifier unit (P.A. tuning condensers and coils with click-stop mechanism and aerial tap switches, H.F. ranges), and a tuning unit (M.F. range iron-dust core coil, with aerial and anode tap switches). A list of the type and reference numbers of the units is given in the following table:—

Transmitter	Drive unit Type	Stores Ref. 10D/	Output unit Type	Stores Ref. 10D/
T.1154	2	117	2	108
T.1154A, B	7	521	8	12140
T.1154C	6	495	7	498
T.1154D	13	732	10	738
T.1154E	14	733	11	739
T.1154F	20	1910	23	1553
T.1154H	30	1973	34	1965
T.1154J	31	1974	35	1966
T.1154K	32	1975	36	1967
T.1154L	33	1976	37	1968
T.1154M	34	1977	38	1969
T.1154N	35	1978	39	1970

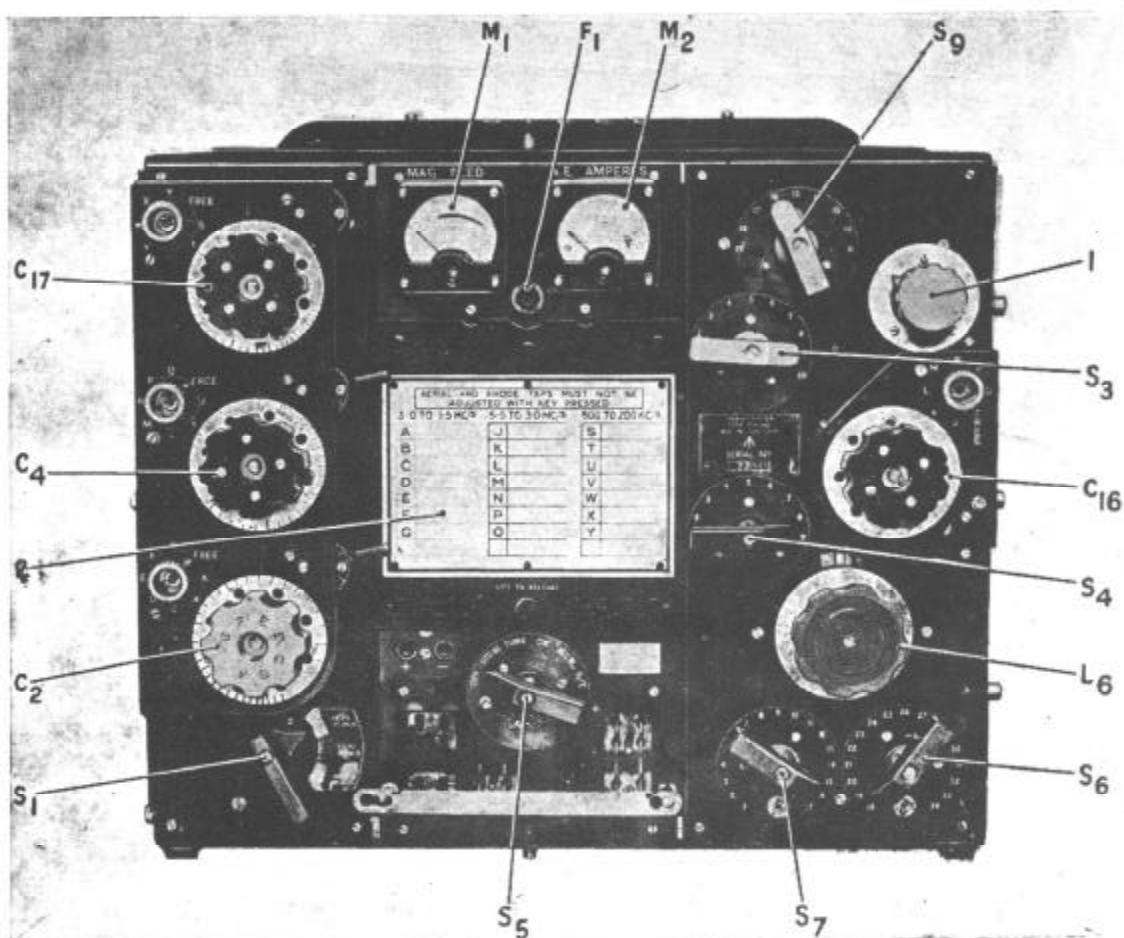

1. Variometer control, Range 2A
2. Cover of valve compartment, with calibration table

FIG. 16.—T.1154L, FRONT VIEW

83. Three views of a transmitter T.1154L are given in fig. 16 to 18. Fig. 16 shows the altered panel layout compared with the other transmitters in the series. The rotating coil of the variometer L_4 for Range 2A is controlled by the knob (1). Switches S_3 and S_8 are respectively the aerial and anode tap controls for this range. The cover plate (2) of the valve compartment carries the table for entering click-stopped frequencies and switch settings. This is similar on all transmitters, except that on those with the multi-click mechanism eight frequencies can be click-stopped on each range instead of seven. In the end view, fig. 17, the rotor (1) of the variometer L_4 is visible. Another view of the variometer is given in fig. 18. This transmitter has a ganged four-section toggle-operated frequency range switch similar to that fitted to transmitters T.1154, T.1154A, B, D, E, J, and N. The operating bar is shown at (1) in fig. 18.

Multi-click mechanism

84. Fig. 19 shows the multi-click type of click-stop mechanism fitted to the earlier types of transmitter (see Table 2). It is applied to the drive of the three M.O. tuning condensers and to the P.A. condensers for the H.F. ranges. The mechanism consists of eight split rings (click-rings) mounted behind the condenser knob, and able either to rotate with the knob or to remain free on the spindle. Eight notched, spring-loaded levers normally bear on top of the rings, and a lettered tab on each ring engages with the notch in its appropriate lever as the condenser is rotated, holding the spindle rigid until the knob is turned further. On the face of the condenser knob are eight screws, lettered to correspond with the rings. When a screw is tightened it causes its own ring to rotate with the condenser, and when slackened the knob can be rotated without the ring turning.

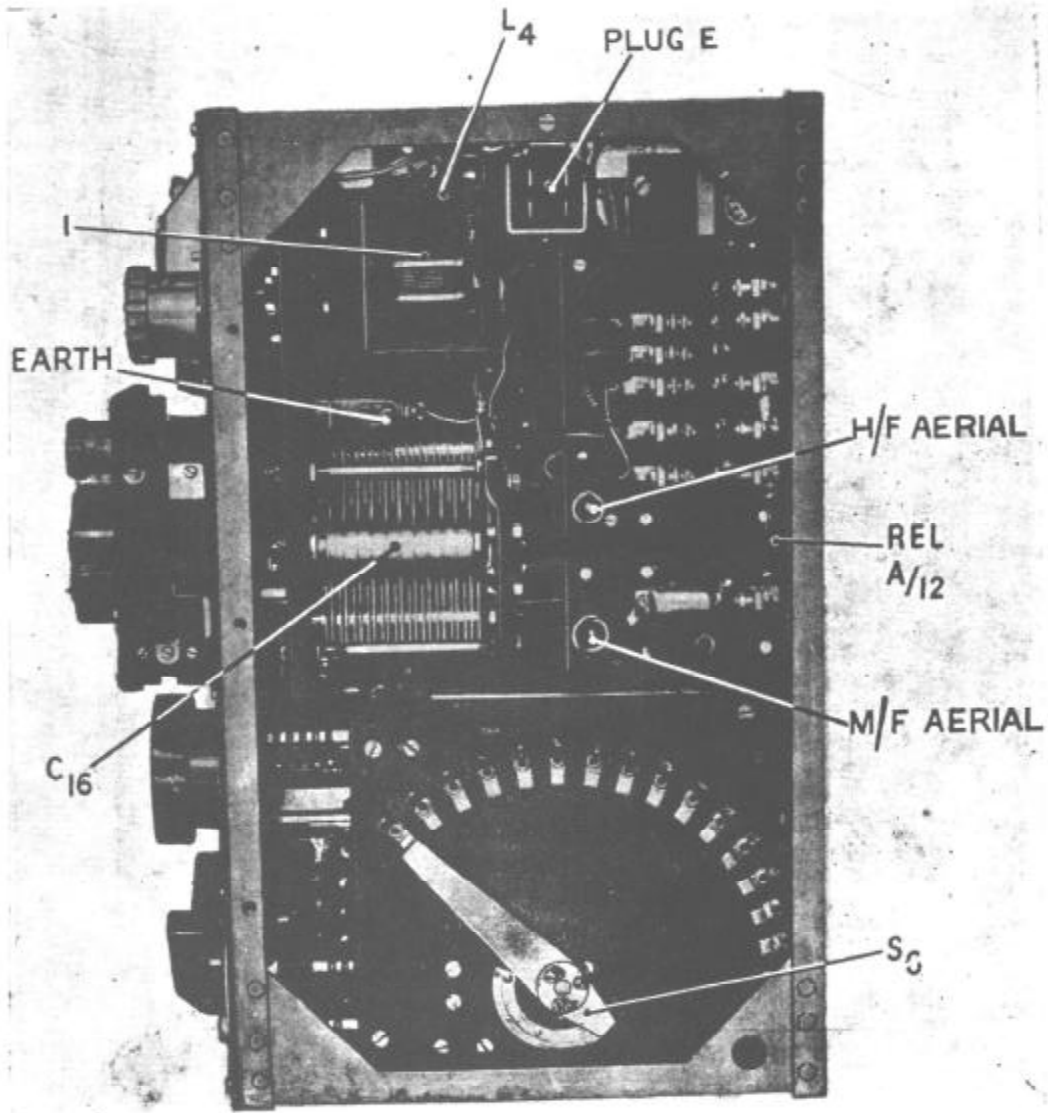

1. Rotor of P.A. tuning variometer, Range 2A

FIG. 17.—T.1154L, END VIEW SHOWING RANGE 2A VARIOMETER

85. A BLUE range condenser knob is shown in the figure. On this range the rings and their holding screws are lettered A to H as shown. On the RED range the lettering is J to R and on the YELLOW range S to Z.

86. To use the mechanism, a letter is chosen for the frequency it is desired to set up, and the condenser is rotated until the tab bearing the letter is felt to engage with the notch in its lever. The appropriate screw on the face of the condenser knob is then slackened, after which the condenser can be turned to tune to the required frequency without the click-ring moving. When this has been done the screw is tightened and subsequently every time this click-stop engages the condenser will be firmly held in the correct setting for the frequency chosen. An aperture in the cover over the mechanism enables the lettered tabs to be seen as they come into position under the notches in their levers.

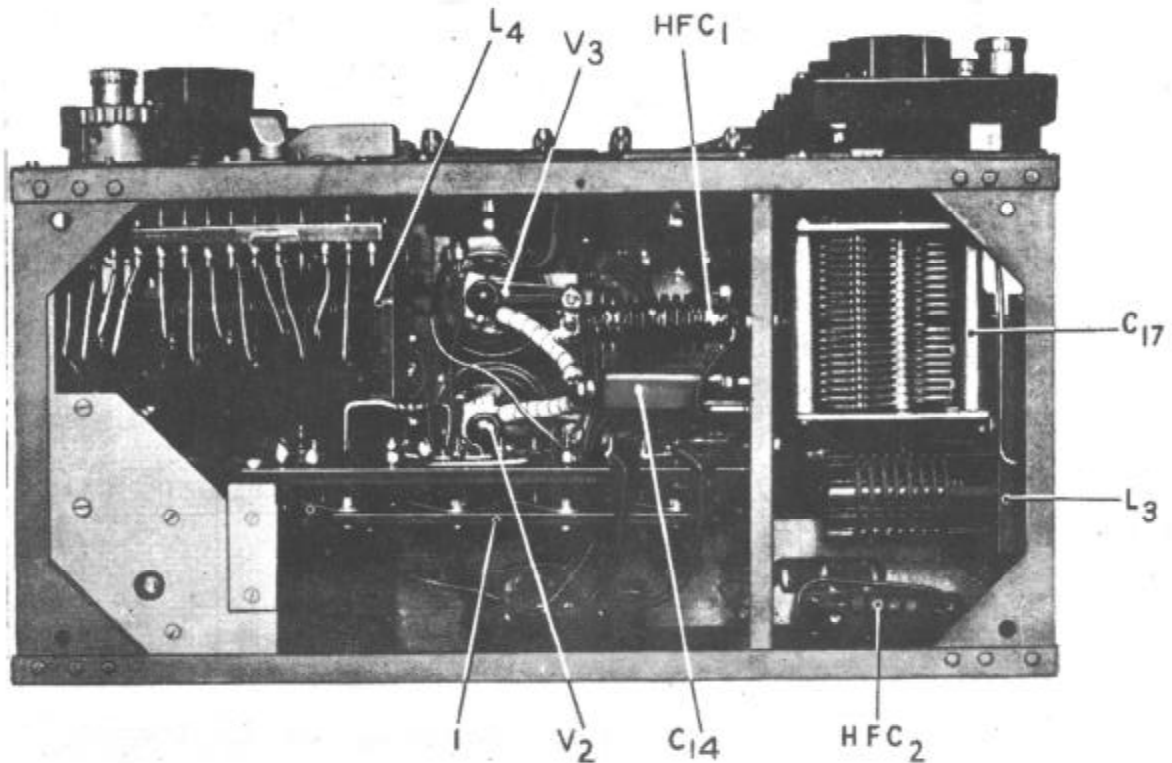

1. Operating bar of four-section frequency range switch

FIG. 18.—T.1154L, TOP VIEW

87. A control knob is provided on each mechanism, operating a cam which will lift all the levers clear of the click-rings so that the condensers can be rotated freely. In this case a friction drive comes into action on the condenser spindle to prevent the condenser shifting off its setting due to vibration.

88. The click-stop mechanisms on the M.O. condensers for the H.F. ranges are provided with compensating handles to shift the slotted levers backwards and forwards. Any click-ring engaged with a lever is therefore slightly rotated and this provides a variation of frequency of about plus or minus 0.1 per cent.

Uni-click mechanism

89. The advantage of the Uni-click mechanism, fitted to the transmitters as shown in Table 2, is that only one click-stop is brought into action at a time on a given range. Like the Multi-click mechanism, it is provided on all M.O. tuning condensers and on the P.A. condensers for the H.F. ranges. It will be observed that only one click-stop mechanism is fitted on the P.A. side of the T.1154L (see fig. 16). This is because it is only on Range 2 of this transmitter that condenser tuning of the P.A. stage is used, Ranges 2A and 3 having variometer and permeability tuning respectively.

90. The construction of the mechanism is shown in fig. 20. It consists of two main assemblies, the click-lever assembly on the transmitter panel and the click-ring assembly on the control knobs.

91. The click-lever assembly consists of a cradle accommodating eight spring-loaded levers which ride on the periphery of a slotted octagonal cam. When the selector knob is turned to any one of its eight positions (seven are identified by letters and the eighth is labelled FREE) the cam rotates, and one lever at a time drops into its associated slot on the cam, the form of which prevents the remaining seven levers from dropping. Each of the seven front levers is notched; the eighth lever (at the back of the assembly) carries a cork-lined brake shoe and falls when the pointer of the selector knob is at FREE. On the compensating type of click-lever assembly (Stores Ref. No. 10D/973), a small compensating lever mounted in an eccentric bearing provides a means of moving the group of spring-loaded levers to and fro through a very small distance so that if the frequency of the transmitter has drifted slightly from that to which it was pre-set, the operator can make the small frequency correction necessary without interfering with the pre-set click-stop. This type is fitted to the M.O. control knobs of the H.F. ranges and permits a variation of frequency of about 0.1 per cent. On the non-compensating type (Stores Ref. No. 10D/974), as fitted to the P.A. controls this facility is not provided.

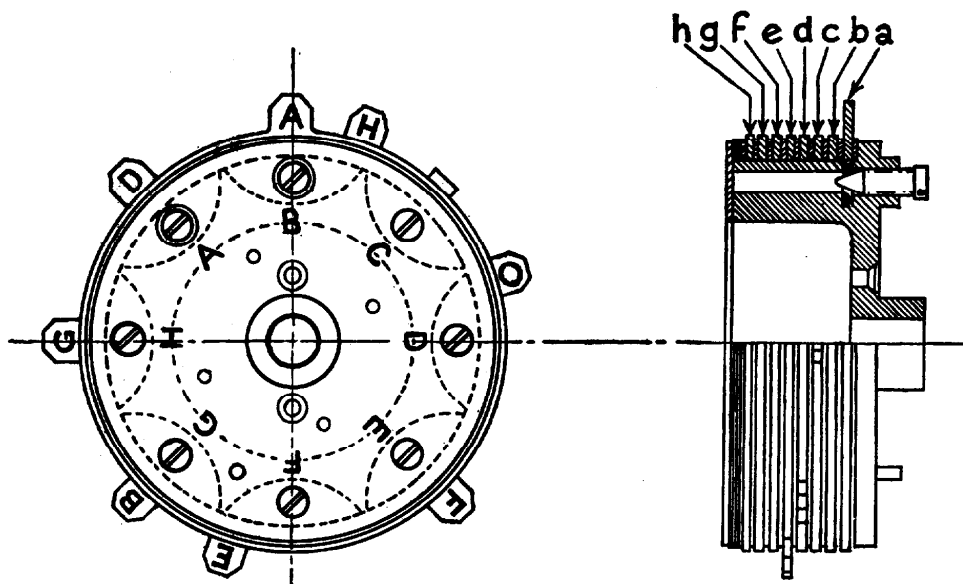

FIG. 19.—MULTI-CLICK MECHANISM

92. The click-ring assembly comprises seven separate rings, each having one projecting tooth shaped to fit into the notch on its associated selector lever. Locking screws, identified by letters embossed on the control knob, are provided, one for each ring. When a screw is tightened, the ring associated with it is held fast and rotates with the knob. Loosening the screw frees the ring and renders it independent of movements of the control knob. The ring controlled by each screw is positioned immediately below the lever which will fall when the selector knob pointer is turned to the corresponding letter; thus, when the selector knob points to G, the lever G will fall. If the screw G is then loosened the ring will be held in position and the knob can be turned to any required frequency without disturbing the ring; by tightening the screw this frequency is pre-set, as the tooth on the ring controlled by the screw G will always click into the same position when the selector knob is turned to G again.

VALVES AND POWER SUPPLIES

93. Two types of valve are used in the transmitter. The M.O. and modulator valves are type VT.105 (Stores Ref. 10E/216). These are non-metallised, indirectly-heated triodes, mounted on standard 5-pin bases. Valves with a ceramic base must always be used in the M.O. position. Some valves of the type have an ordinary moulded base and are eligible for use only in the modulator stage. The valves take 0.7 amp. heater current at 6 volts. The anode voltage rating is 250 V.

94. The power amplifier valves are directly-heated pentodes of type VT.104 (Stores Ref. 10E/215) taking 1.3 amp. filament current at 6 volts and rated at 1250 V. on the anode. They have a standard ceramic 5-pin base, and the anode connection is brought out to a top cap.

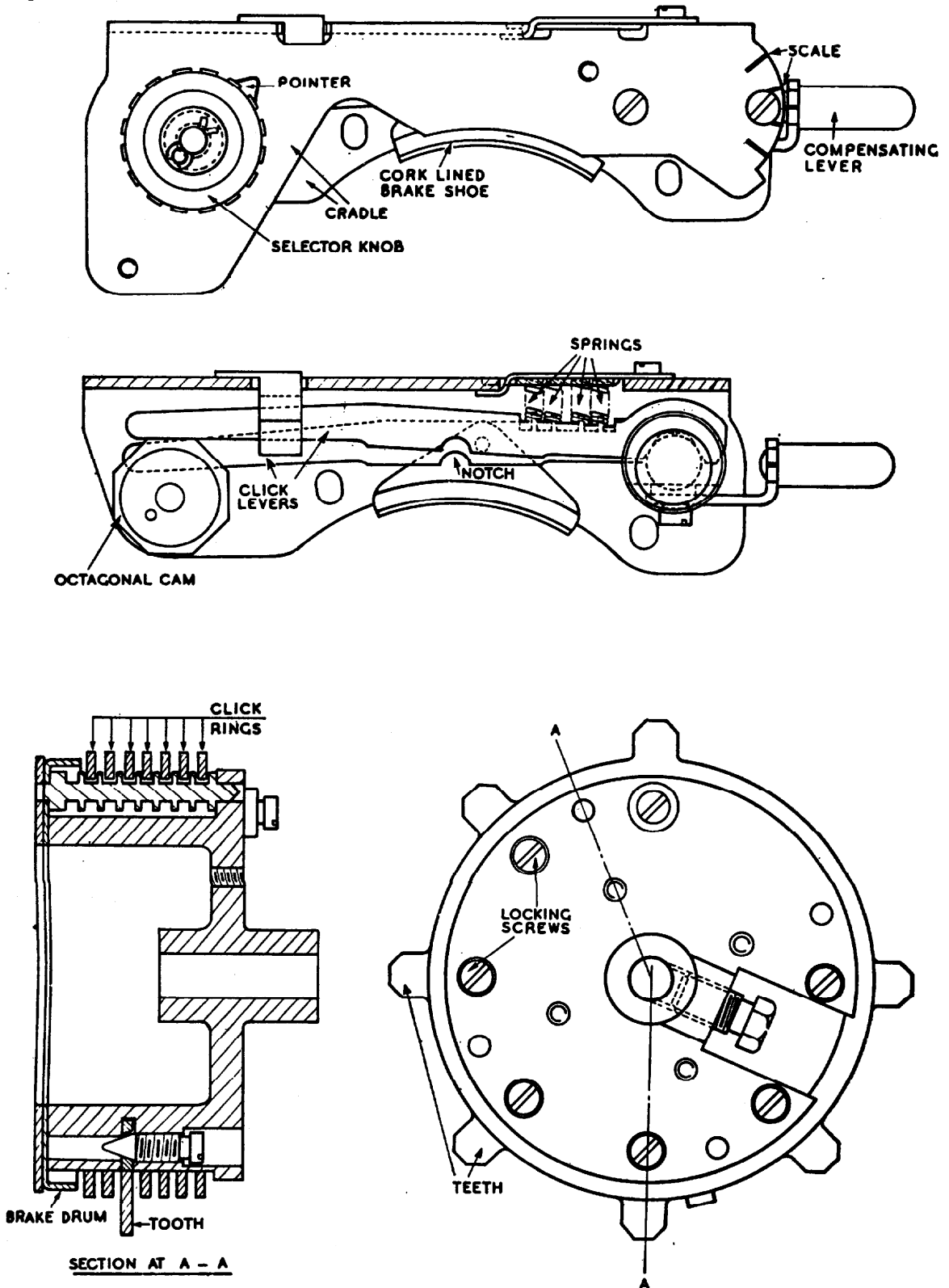

FIG. 20.—UNI-CLICK MECHANISM

L.T. power units

95. Two rotary transformer power units provide the supplies for the transmitter and its associated receiver R.1155, and are available for either 12 V. or 24 V. input. They are known respectively as the L.T. power unit and the H.T. power unit, the former supplying also H.T. for the receiver. A list of the various types of L.T. power units is given below:—

<i>Stores Ref.</i>	<i>Type</i>	<i>Input (Nominal)</i>	<i>Input (Actual)</i>	<i>Rated Outputs (d.c.)</i>
10K/19	34	12 V.	10.3 V.	217 V. 110 mA., 7 V., 13 amps.
10K/61	34X	14 V.	14 V.	245 V. 110 mA., 8.1 V., 13 amps.
10K/13065	34A	12 V.	10.3 V.	217 V. 110 mA., 7 V., 13 amps.
10K/20	35	24 V.	18.5 V.	217 V. 110 mA., 7 V., 13 amps.
10K/13066	35A	24 V.	18.5 V.	217 V. 110 mA., 7 V., 13 amps.

96. The L.T. power units type 34 and 34X are now obsolete.

97. Types 34A and 35A are modifications of the original types 34 and 35 to permit of their use in aircraft where an additional R.1155, operated by the navigator, is installed. They incorporate an extra relay which interrupts the H.T. supply to the navigator's receiver when the transmitter H.T. power unit is started up. A modification to the H.T. power unit is also involved.

98. The L.T. power unit type 34X had an arrangement whereby a 2 V. 20 amp. hr. accumulator was switched into circuit to increase the input when the aircraft generator was off charge.

H.T. power units

99. The H.T. power units are listed below:—

<i>Stores Ref.</i>	<i>Type</i>	<i>Input (Nominal)</i>	<i>Input (Actual)</i>	<i>Rated outputs (d.c.)</i>
10K/17	32	12 V.	13.2 V.	1,200 V., 200 mA.
10K/13063	32A	12 V.	13.2 V.	1,200 V., 200 mA.
10K/1474	32B	12 V.	13.2 V.	1,200 V., 200 mA.
10K/18	33	24 V.	27.4 V.	1,230 V., 200 mA.
10K/13084	33A	24 V.	27.4 V.	1,230 V., 200 mA.
10K/1470	33B	24 V.	27.4 V.	1,230 V., 240 mA.

100. Power units type 32A and 33A are used in conjunction with the L.T. power units type 34A and 35A in aircraft with a navigator-operated R.1155. Types 32B and 33B are arranged so that when in operation 12 V. or 24 V. is applied to a relay which earths the aerial of the TR.9 or TR.1196 in the aircraft or marine craft.

101. A full description of all these power units, and of the modifications required to convert the basic types to the A or B varieties, is given in A.P.1186D, Vol. I, Sect. 8, Chap. 5.

Power supplies of ground installations

102. Transmitters type T.1154D and type T.1154E obtain the input to their power units from a rectifier type 26 (Stores Ref. 10D/745). This is a 230 V. 50 c/s instrument forming part of the tender, signals, type 309, which accommodates the mobile ground station T.1154D or E—R.1188.

103. When the T.1154-R.1155 installation is used on the ground for training purposes the input to the rotary power units may be obtained from 200-250 V. 50 c/s a.c. mains *via* a power unit type 115 (Stores Ref. 10K/351), with two 12-volt accumulators in series "floating" across it. Alternatively the rotary transformer power units can be dispensed with and the necessary d.c. inputs for transmitter and receiver derived direct from 200-250 V. 50 c/s mains *via* a power unit type 114 (Stores Ref. 10K/350). Both these power units are described in A.P.1186E, Vol. I, Sect. 6, Chap. 4.

INSTALLATION

104. A diagram of a typical T.1154/R.1155 installation is given in fig. 21, Chap. 2 of this publication. It will be seen that the transmitter is the main focal point for all the wiring. The connectors from the power units plug into the transmitter and so also do the two aeriels, fixed and trailing, and the receiver inter-connection. The D/F circuits alone (loop and visual indicators) plug into the receiver. The transmitter is placed on top of, or to one side of, the receiver.

Resistance units, types 47, 52, 52A

105. Since the voltage of the aircraft accumulators will alter between charge and no-charge conditions a resistance cut-in arrangement is included in the positive lead from the aircraft accumulator to the L.T. power units, types 34, 34A, 35, or 35A. This compensates for the variation,

and maintains the L.T. output of the power unit between 6.5 and 7 volts. The resistance unit is included on the typical installation diagram, fig. 21, Chap. 2. The resistance is switched in and out of circuit by means of an auxiliary relay, type 219 (Stores Ref. 10F/493) on 12-volt systems, or by relay type 220 (Stores Ref. 10F/494) on 24-volt systems. The resistance unit type 47 is designed for 12-volt and the unit type 52 or 52A for 24-volt installations.

106. In the resistance type 52A, an additional resistance element, type 4773 (Stores Ref. 10W/16125) is connected between terminals 6 and 7 of the unit to improve the heater voltage regulation. There is no connection to terminal 7 in the type 52 unit, and the full resistance is in circuit with the lead to the generator on terminal 6.

107. It will be seen from para. 95 that the actual input of the L.T. power units used with 24-volt aircraft systems is only 18.5 volts. Part of the resistance type 52 or 52A is therefore always in circuit irrespective of whether the aircraft generator is charging or not.

108. With the leads connected to terminals 1 and 6 (or 1 and 7 on type 52A) the whole resistance is in circuit. This condition is not always required, and instructions for determining the correct terminal to which to connect the lead from the resistance to the L.T. power unit are given in para. 119.

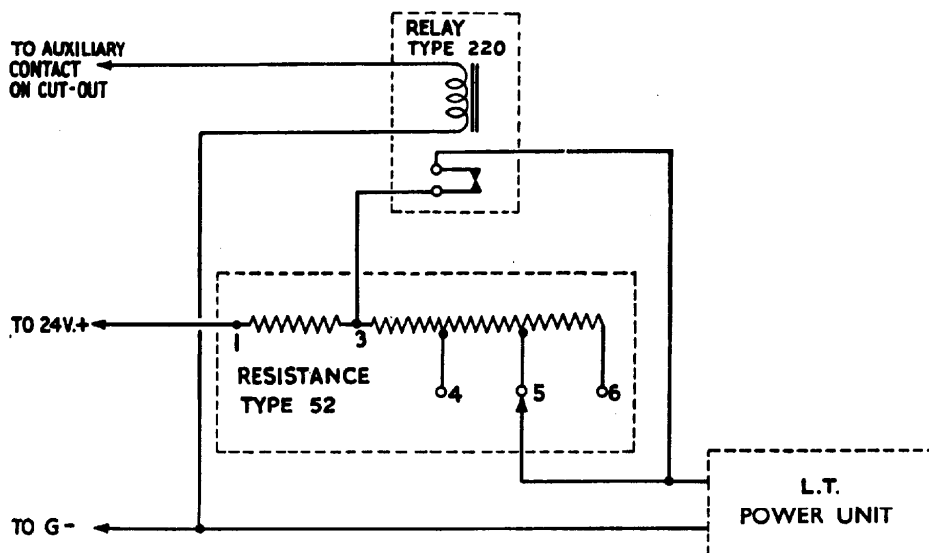

FIG. 21.—CONNECTIONS OF RESISTANCE, TYPE 52

109. A Londex relay type 219 (12-volt) or type 220 (24-volt) is connected across all or part of the resistance. When the aircraft accumulator is not charging, the relay contacts are closed and the part of the resistance across which the relay is connected is short-circuited. When the voltage of the aircraft generator rises sufficiently to close the cut-out and begin charging the accumulator, the relay is energised from an auxiliary contact on the cut-out so that its contacts break and the resistance is brought into circuit. A simplified diagram of this arrangement with the type 52 resistance is given in fig. 21. The relay is connected between terminal 3 of the resistance and the terminal from which the lead is taken to the input of the L.T. power unit (in this case terminal 5), so that the part of the resistance between terminals 1 and 3 is always in circuit. With the type 47 resistance, in 12-volt installations, the relay is connected across the whole of the portion of resistance in use.

110. On some early installations the relay was operated by a manual switch, the switch being closed by the operator in order to break the relay contacts when the aircraft generator was charging.

Connectors, plugs, and sockets

111. Details of the connections to the individual pins of the plugs and sockets on the transmitter are given in the insets to fig. 4 to 6. The types of connector between each plug and socket on the transmitter and the other items of equipment in the installation are given in the installation diagram and schedule in Chap. 2.

112. The connection from the microphone sockets on the transmitter is taken through a plug type 217 and a suitable length of Dumet 4 to the intercomm. panel of the aircraft. The earth connection consists of Uniflex 19 terminating at the transmitter in a socket type 135, and in a hook end at the earth terminal.

113. The transmitter may be back, table, or base mounted (depending upon the aircraft layout), using the mountings quoted in the installation schedule, Chap. 2, fig. 21.

114. Due to the heavy current taken by the apparatus, separate cables are used for the H.T. and the L.T. power units and these are taken to the aircraft main distribution panel. Each supply is separately fused. With a 12-volt system 70-amp. minimum fuses are used; in a 24-volt installation a 20-amp. fuse is used for the L.T. power unit and a 60-amp. for the H.T. power unit. The recommended supply cables are 37-amp. cable in the 12-volt and 19-amp. cable in the 24-volt installation. The supply leads need not be of metal-screened cable.

Type 47 and 52 resistance positioning

115. In the positive supply lead to the L.T. power unit is connected the variable pre-set resistance, type 47, type 52 or type 52A, mentioned in para. 105. This resistance should be positioned in the run of the wiring so that the length of leads is not thereby greatly increased. As the power dissipated by this resistance may be of the order of 100 watts it is essential to keep it away from anything that might be damaged by heat. It should be mounted vertically and in an open space so that air may freely circulate through it. Although once set the resistance does not require any further attention, on one aircraft of each type an adjustment of the tappings in the air is very desirable.

116. The function of this resistance is to maintain the input voltage to the L.T. power unit approximately constant whether the aircraft is on the ground or in the air with the battery on charge. There would normally be a difference of perhaps 4 volts between these two conditions and it has been found that this variation has a detrimental effect on the valve filaments. A certain section of the resistance is therefore inserted in circuit in the air.

Setting the resistance

117. With the type 47 resistance (12-volt) there is no resistance permanently in circuit and the necessary amount is switched in when the aircraft is airborne. With the type 52 or 52A resistance (24-volt) a certain part of the resistance is always in circuit. To determine the correct value of resistance to use it is advisable to make a test, first on the ground, and then in the air, with the aircraft main electrical generator delivering its normal voltage.

118. Assuming that the aircraft has a nominal 24-volt supply and that the resistance is a type 52, ensure that the positive input lead is taken to terminal 1 of the resistance. Arrange to measure the valve heater voltage of one of the transmitter valves by connecting a voltmeter across the pins. Connect the positive lead from the L.T. power unit to terminal 6 of the resistance so that all the resistance is in series with the L.T. power unit. Switch on the power unit by turning the master switch in the transmitter to STD.BI and measure the valve heater voltage. It will probably be around 5 volts, which is much too low. Bring the tapping down from 6 to 5 and so on until the valve heater voltage is somewhere between 6.5 and 7 volts. That tapping is the one to which one side of the relay connection (fig. 21) must be made. It is usually "3", so that the portion of resistance between 1 and 3 is always in circuit, on the ground or in the air. The aircraft accumulator should not be on charge during this test. The correct tapping for the lead from the power unit to the resistance must be ascertained in the air as below.

119. When the aircraft is airborne, and the engine-driven generator charging normally, again measure the valve heater voltage across the pins of one of the transmitter valves, beginning again with the lead from the L.T. power unit connected to terminal 6 on the resistance unit. The reading should be approximately 6.3 volts. If below this figure, the connection from the L.T. power unit will have to be made to terminal 5, or even to terminal 4 of the resistance. The actual value on resistance in circuit at the different tapping points on resistances type 47 and 52 are as shown below:—

<i>Tap No.</i>	<i>Type 47</i>	<i>Type 52</i>
3	0.10 ohms	0.38 ohms
4	0.11 ohms	0.695 ohms
5	0.12 ohms	0.715 ohms
6	0.13 ohms	0.735 ohms

External equipment

120. The aerial switching unit, type J, or aerial plug board, which is sometimes used in place of it, is positioned between the transmitter and the aerial lead-in points so that the "run" of the aerial leads is clean and short. It is easily accessible for operational purposes. Although some

few aircraft were fitted with plug boards upon delivery, selector switches are generally installed later. All leads, therefore, are made long enough to reach the appropriate sockets in the switch even though the switch is not fitted at the time.

121. With the aerial plug board in use, it is necessary to short-circuit the pins 13 and 14, 15 and 16 of the socket type 175, which engages with transmitter plug E. This is done by using a dummy socket appropriately wired.

122. The aerial ammeter (Chap. 2, fig. 21, item 128) supplied for use on the H.F. ranges is an external fitting and is positioned in the run of the H.F. aerial lead between the transmitter and the aerial switch or plug board. The lower fixing bolt for this ammeter is attached to a bracket of insulating material such as wood or plastic and not to the metal structure.

123. A small fixed condenser (Chap. 2, fig. 21, item 63) is supplied for use with the aerial selector switch only; its function is to load the fixed aerial for M.F. operation. This condenser need not be installed in an accessible position.

124. All aerial leads between the transmitter and the selector switch and between the switch and the aerial lead-in points are of stout, high-voltage cable such as Unispark 7 or an approved alternative. The run is kept as short as possible. These aerial leads are stood away from adjacent metal work, particularly sharp points and angles, not only to reduce losses but also to avoid the possibility of brush discharge and breakdown. A minimum spacing of $1\frac{1}{4}$ in. between the conductor and the nearest metal work is aimed at but not always achieved. On medium frequencies the R.F. voltage between aerial terminals and earth may reach 6,000.

125. Fixed aerial lead-in insulators and trailing aerial fair-leads are installed with the possibility of the 6,000 volts in mind. The fixed aerial, though normally used for H.F., may be used for M.F. should the trailing aerial be lost.

OPERATION

126. The procedure on the H.F. ranges, except Range 2A of the T.1154L, will be considered first. Fig. 1 and 16 should be consulted for the positions of controls and meters.

127. Set switch S_1 to the frequency range required, and ensure that the aerial tapping switch for this range (S_2 or S_3) is on tap No. 1. All controls for a given range can be identified by being of the same colour. See that the Type J switch, if installed, is at NORMAL. With transmitters T.1154C, F, H, K, and M the three-point socket on the panel (see para. 72) should be inserted with the letter N against the arrow.

128. Turn the master switch, S_5 , to STD.BI. The L.T. power unit will then start up, and transmitter and receiver valve filaments will glow. After a few seconds' pause, turn S_5 to TUNE, whereupon the H.T. power unit will start.

129. The M.O. condenser (C_2 or C_4) for the range in use must now be adjusted for the frequency required. The condenser dials are calibrated in frequencies, but the normal procedure in aircraft is to back-tune to the receiver R.1155, which will either have been tuned to the station with which it is desired to communicate, or set to the required frequency by means of its own calibrated dial.

130. Check that the control knob (1, fig. 1) of the click-stop mechanism for the range in use is at FREE. Press the key, and rotate the M.O. condenser until the magic eye tuning indicator on the receiver closes (displays minimum shadow). During this process the receiver master switch should be at OMNI., and the receiver volume control adjusted so that the magic eye just closes and reopens, without overlap, when the transmitter passes through the position of resonance.

131. When the eye closes, the operator should check the setting of the M.O. dial by its calibrated scale to ensure that it is not on a harmonic of the required frequency.

132. The M.O. stage being now set up, the P.A. stage is tuned by rotating C_{15} or C_{16} (with their click-stops at FREE) until a dip is observed on the meter M_1 . If more than one dip occurs, the deeper dip indicates the correct tuning point. The two dips, if close together, are caused by the fact that there is some overlap between the frequency coverage of the P.A. tuned circuits with the commutator switches on the condensers open and closed. One combination of inductance and capacity, however, gives the greater efficiency and is indicated by the deeper dip. On some frequencies, of course, minor dips due to harmonics will be encountered. Remember that C_{15} and C_{16} rotate through a full 360° .

133. Raise the key, and move S_3 or S_4 to tap No. 2. Again adjust C_{15} or C_{16} for maximum dip. Continue this process, advancing S_3 or S_4 one tap at a time, until M_1 dips to just below the green line marked on its scale. The green line represents an input of 65 mA.

134. The aerial tap switches S_3 and S_4 must not be moved while the key is pressed, or arcing will occur at their contacts.

135. When tuning the P.A. on the RED range the reading of M_1 will momentarily fall to zero when the cam-operated contacts on C_{16} break (see para. 53). This must not be confused with a dip.

136. When the dip on M_1 has been loaded up approximately to the green line as described, the master switch S_5 is turned to c.w. On pressing the key, the pointer of M_1 should now rise to the beginning of the red sector of its scale (100mA) and aerial current should be indicated on the external aerial ammeter if fitted. The reading of this meter will vary widely with different aerials and is to be regarded merely as an indication that R.F. output is present.

137. Should M_1 exceed 115 mA with S_5 on C.W., the aerial tap switch must be turned back one position and the P.A. stage retuned.

Tuning T.1154L on range 2A

138. To tune the transmitter T.1154L on Range 2A the M.O. stage is set up as described in para. 126 to 131. Referring to fig. 16, the aerial tap switch, S_9 , is placed on tap No. 10 and the anode tap switch, S_8 , on tap No. 19. With the key pressed, rotate the variometer control (1) to find a dip. Reduce the setting of S_9 one tap at a time, lifting the key at each adjustment, and on each tap rotate the knob (1) until the setting of S_9 is found on which the deepest dip on M_1 is obtainable. Now reduce the setting of S_9 one tap at a time, rotating the variometer (1) and if necessary adjusting S_8 at each step as before until the meter M_1 dips only a trifle below the green mark on its scale. Switch S_9 must not be moved with the key depressed. The master switch, S_5 , may then be turned to c.w., when the reading of M_1 will go up to approximately 100 mA on pressing the key.

Tuning procedure on M.F.

139. To tune all transmitters on the YELLOW range (M.F.), the frequency range switch S_1 is first turned to the appropriate position, and the anode and aerial tap switches, S_8 , S_7 , are set at taps No. 18 and 17 respectively. The procedure for switching on and for tuning the M.O. stage is the same as on the H.F. ranges.

140. With the transmitter master switch, S_5 , on TUNE, press the key and rotate the control knob of L_6 to find a dip on M_1 . Reduce the setting of S_7 one tap at a time, tuning with L_6 at each step, until the deepest dip is obtained.

141. The setting of S_8 is now increased one tap at a time, again pressing the key and rotating L_6 to find a dip at every adjustment, until M_1 dips to just below the green line on its scale. Move S_8 to c.w. and press the key. The reading of M_1 should now increase to approximately 100mA and aerial current should be indicated on M_2 .

142. It will sometimes be found that on a given setting of S_8 , the dip on M_1 is well below the green line, whereas on the next tapping higher, the dip is above the line. In these circumstances S_8 should be turned back to the position on which the dip was too deep, and the aerial switch S_7 should be advanced one tap (i.e. its setting reduced). A new dip will then be found when L_6 is rotated and the loading up procedure can again be proceeded with.

143. Switches S_8 and S_7 must never be moved while the key is pressed.

R/T and M.C.W. operation

144. The tuning procedure for R/T or M.C.W. operation is exactly the same as that already described, except that when M_1 has been loaded up to the green line, the master switch S_5 is turned to m.c.w. or to R/T, as required, instead of to c.w. The reading of M_1 will then remain approximately on the green line when the key is pressed (since the suppressor grids of V_2 and V_3 still have a negative bias) but will fluctuate when modulation takes place. The key must be depressed, or the pilot's shorting switch closed, the whole time R/T transmission is taking place.

Notes on use of click-stops

145. When a frequency is to be click-stopped, the letter to be used is selected first and the click-stop with that letter engaged as described in para. 84 onwards. It is more convenient to set up the click-stop with the highest letter on the range first (e.g. G or H on Range 1, according to whether the Uni-click or Multi-click mechanism is fitted). The vernier levers on the M.O. dials are set to the second position from the bottom. Slacken the appropriate screws on the face of the condenser dials so that the click-stop will remain engaged while the normal tuning procedure is carried out.

146. After tuning, tighten the screws again. Write the frequency allotted to the click stop chosen in pencil on the table on the cover of the valve compartment, together with the setting of the aerial and anode tap switches. On transmitters with the Multi-click mechanism, the click-stop letter should also be written on the scale behind the condenser knob, against the indicating pointer engraved on the cover over the mechanism. Unless this is done it is difficult for the operator to see when a desired click-stop is engaged, the lettered tabs on the click-rings being small, and visible only momentarily as they pass behind the aperture in the cover. With this mechanism, also, frequencies should not be click-stopped if separated by less than 25 kc/s. on the BLUE range, 10 kc/s. on the RED range, and 1 kc/s. on the YELLOW range. There is no restriction on spacing between frequencies when using the Uni-click mechanism.

147. If frequency settings alter due to temperature changes at height, the vernier levers on the M.O. dials (H.F. ranges only) are moved *upwards* to reduce frequency and *downwards* to increase frequency. A variation of about 0.1 per cent. is obtainable.

148. No click-stop facility is provided on the M.F. range output circuit tuning control, since M.F. operation is normally on the trailing aerial and setting-up must be carried out in flight.

Emergency working

149. If the normal aerial for the frequency required is not available, H.F. transmission on trailing aerial or M.F. on fixed can be carried out by turning the type J switch to the appropriate position, or shifting the plugs on the aerial plugboard. It will then be necessary to release the output circuit click-stop and re-tune.

150. When transmitting H.F. on trailing aerial with transmitters T.1154C, F, H, K, and M, better results will be obtained if the three-point socket labelled N-X on the panel is reversed so that the letter X is against the arrow.

Operating figures

151. Table 3 gives typical specimen figures of anode and total input currents to the transmitter, and aerial currents. It must be understood that the aerial currents will vary widely between different installations and are given only as a rough guide. The figures are for the T.1154M, but on the common frequencies are applicable to the other types.

TABLE 3
Typical performance figures

Freq.	Ae tap	Anode tap	C.W.			M.C.W.			Remarks
			Aerial amps.	Anode mA	Total mA	Ae amps.	Anode mA	Total mA	
16.7 Mc/s.	2	—	1.0	143	231	0.7	88	175	Range 1
10.0 Mc/s.	2	—	0.6	99	187	0.4	66	154	Range 1
6.5 Mc/s.	5	—	0.95	121	200	0.55	66	146	Range 2
5.0 Mc/s.	6	—	0.95	154	242	0.65	77	165	Range 2
3.5 Mc/s.	2	—	1.4	121	209	0.95	72	149	Range 3
2.5 Mc/s.	4	—	1.6	121	209	0.9	72	143	Range 3
500 kc/s.	1	30	1.55	116	200	1.0	70	155	Range 4
400 kc/s.	5	30	1.6	116	204	1.0	61	145	Range 4
300 kc/s.	9	29	1.6	120	208	1.0	61	145	Range 4
200 kc/s.	14	21	1.0	116	155	0.7	75	130	Range 4

Indications of meter M₁

152. Full-scale deflections of the meter M₁ on the M.F. ranges for various settings of the aerial tap switch, S₇, were given in para. 49. Some intermediate indications are shown in Table 4 since it is found that operators are often perturbed by the apparently high inputs recorded when tuning up on the M.F. range and are liable to hasten the process unduly.

TABLE 4
Feed meter readings

Meter division	True current in mA				
	Tap 1-9	Tap 10-11	Tap 12-13	Tap 14-15	Tap 16-17
6½	65	55	45.5	36	26
10	100	85	70	55	40
30	300	255	210	165	120

153. The green line on the scale is marked at 6½ divisions and the red sector runs from 10 to 30 divisions. On taps 1 to 9 and on the H.F. ranges the meter calibrations show the true current taken by the P.A. valves.

154. When power supplies and valves are in order, the meter should read at least 200 mA if the transmitter is switched to the YELLOW range, switches S₆ and S₇ are on taps 18 and 17 respectively, and the key is pressed with the master switch at TUNE. The M.O. and P.A. circuits must not be in resonance for this test and it may be necessary to swing the control of L₆ to obtain the highest reading. In the circumstances described the indicated input of 200 mA represents an actual input of about 80 mA.

Airborne fault-finding

155. Finding and rectifying faults on this equipment must be considered from the points of view both of the aircrew wireless operator and the ground mechanic. These paragraphs are written to review some of the most common troubles experienced by operators, and all are capable of easy cure in the air if tackled with a good understanding of the equipment. Charts and tables of faults can never be a complete substitute for such an understanding.

156. Where a fault develops in the air which the operator is unable to remedy on account of his comparatively limited resources, he can do much towards its speedy rectification on the ground if his understanding of the equipment is such that he can report accurately on the symptoms and suggest where the trouble lies. The unsatisfactory statement that "the transmitter is u/s" must have wasted many man-hours among mechanics detailed to investigate faults, and it is essential that from their earliest acquaintance with the equipment operators should be thoroughly cross-examined as to the symptoms of the troubles they experience, and encouraged to attempt to localise the fault by a process of reasoning. The following list of common failures is addressed particularly to instructors.

No input

157. When this is reported, do not hesitate to satisfy yourself that the operator knows the difference between input and output. No reading on the external aerial ammeter for the H.F. ranges is sometimes reported in this way. When this point is cleared, ascertain whether the H.T. power unit rotary transformer was running. If not, was the type J switch in the D/F or EARTH positions, or was the cable between transmitter plug E and the type J switch disconnected at either end. (The socket under the switch may shake loose, and in some installations is hard to see). A less probable fault than the foregoing, but not to be overlooked by operators, is failure of the H.T. power unit input fuse on the aircraft electrical panel.

158. If the H.T. power unit was running, the cable from the power unit to transmitter plug C should have been checked at both ends, and then the transmitter fuse F₁. Spare fuses for F₁ are carried behind the cover of the valve compartment.

159. Operators must understand that the H.T. power unit will not start unless the L.T. power unit is running, but failure of the latter would normally be indicated by no receiver signals. If in doubt, the operator can look inside the transmitter valve compartment and see that the filaments are glowing normally.

160. Impress upon operators that disconnection of the screened cable linking the H.T. and L.T. power units will prevent both from running.

Input low and dip absent or sluggish

161. Operators must assure themselves that the aircraft charging system is working normally before beginning to change valves. If the reading of the voltmeter on the aircraft electrical panel

is normal, suspect the P.A. valves. If the filament of one is dim, remove it. Re-tune the transmitter using one valve. If both valves look normal, remove each valve in turn and see with which one the better input and dip is obtained. The faulty valve must *not* be replaced in the transmitter.

Note.—If the transmitter is used with one P.A. valve, this valve will be overloaded and must be removed on conclusion of the flight. Transmission should be limited to the minimum necessary for the safety of the aircraft.

High input, no dip

162. Operators must be trained to recognise the normal reading of M_1 , when S_2 is at TUNE and the key is pressed (but the P.A. circuit is not in resonance). If this is slightly exceeded and no dip can be found, the M.O. valve, V_1 , should be changed. It may be replaced by the modulator valve V_4 , provided V_4 has a ceramic base. In these circumstances there will be no sidetone on C.W., and R/T and M.C.W. transmission will be impossible.

No dip

163. If interrogation of the operator does not elicit any amplifying symptoms, it may be suspected that the frequency range switch, S_1 , was in the wrong position. When this trouble is reported on the M.F. range only, a likely cause is the operator's failure to remove the earthing plug at the trailing aerial winch.

Sharp dip, but transmitter will not load up

164. A disconnection between the transmitter and the aerial will cause the above symptom. On the H.F. ranges it may occur through the aerial plug vibrating loose on the transmitter, either of the sockets underneath the external aerial ammeter falling out, or either the H.F. or H.F. AERIAL sockets becoming disconnected at the type J switch.

No output

165. This is usually a manipulation failure, due to using too high a setting of the aerial tap switches (indicated by the needle of M_1 rising above the prescribed limits on C.W.) or to tuning up on the wrong dip. Operators sometimes overlook the fact, however, that there is a short-circuiting switch on the external aerial ammeter. This is operated by two press-buttons labelled SHOR TED and IN CIRCUIT. If the SHOR TED button is accidentally pressed, the ammeter will show no reading.

No sidetone

166. If no sidetone is heard with the transmitter master switch at TUNE and the key pressed the valve V_4 should be changed, assuming that the telephone circuit is known to be in order by signals being heard from the receiver when the key is raised.

No modulation

167. If sidetone is normal with key pressed on TUNE, the valve V_4 is in order. The operator should therefore check that the microphone plug is home in the sockets on front of the transmitter, that all plugs are secure on the aircraft intercomm. panel and that, if an amplifier type A.1134 or A.1134A is in use, the amplifier is switched on, and that the ABC switch on the amplifier is in position c. He must ensure that the reversible plate at the back of the transmitter is fitted with the wording CARBON OR ELECTROMAGNETIC showing as appropriate.

GENERAL FAULT-FINDING AND SERVICING

168. The following instructions are more detailed than the operational hints already given and are intended for the use of mechanics working on the ground.

169. If the transmitter operates normally when connected up to the external supply used for ground testing it is almost certain that the trouble is due to the aircraft supply accumulator, the condition of which should be tested. This should give a minimum of 10.5 or 21 volts (according to the type fitted) on load. If, however, no results are obtained, a cursory examination should be made before removing the instrument from the aircraft in order to ascertain whether any obvious faults exist. Cables and plugs should be shaken from side to side so that the presence of broken connections or loose joints can be detected.

170. Next a new set of valves may be tried, after which, if no result is obtained, the aircraft fuses should be checked. If the fitting of a new set of valves is found to effect a cure, it is advisable that the old valves should be replaced one at a time in order to discover the actual valve (or valves) which is faulty.

Substitution tests

171. If the tests referred to have failed to produce any result it is suggested that the method of substitution should be tried next in order to determine the broad location of the fault. The instrument should be removed from the aircraft by slackening off the locking bolts at the back and lifting it off its shock-proof supports. Another instrument, known to be in working order, should now be fitted in its place, switched on and checked for normal operation in the usual way.

172. By this means it is reasonable to assume that if no results are obtained or the symptoms are the same as before, the trouble is due to some outside cause such as the power units or external wiring in the aircraft, etc., whilst if the transmitter functions in a proper manner the fault will lie in the instrument itself.

Trouble outside transmitter

Power units do not start

173. First of all the master switch of the transmitter should be placed in the STD.B1 position, when the L.T. power unit should start up. This can be confirmed by placing the back of the hand on the top cover or listening for the slight hum made by the rotary transformer when it is running. If the unit fails to start the supply socket situated at one end should be withdrawn and the voltage across the two outside sockets measured on a testmeter type D or other suitable instrument, when a reading of 12 or 24 volts should be obtained.

174. Should, however, the meter show no reading the input cabling should be examined and tested. In order to do this the socket should be withdrawn from the unit and the other end of the cable disconnected from the aircraft supply. The ends of the two leads can then be checked for continuity by placing across them the testmeter type D or similar instrument. It should be observed that the centre contact is for earthing purposes only.

175. The input cabling to the H.T. unit may also be checked at the same time so as to avoid the necessity of having to do so at a later date. Apart from the continuity test of the leads, a check should also be made to ascertain whether the leads are shorting to the external screening of the cabling, by placing the meter across one end of each lead and the screening itself.

176. The foregoing remarks apply to the testing of all cables and leads in the aircraft installation. In a number of cases, however, it will be found that leads are too long for a meter to be conveniently connected across the two ends, and in these circumstances the screening can be used for the checking of continuity. One end of the lead to be tested should be connected direct to the screening and the meter placed across the other end and the screening, but before testing in this manner, a check must first be made in order to make sure that the lead is not shorting to the screening. An installation diagram is given in fig. 21, chap. 2, which will assist in tracing the relative positions of the cables.

177. If these tests reveal no defects, the L.T. power unit itself will have to be examined. First of all the cover should be removed after undoing the four securing screws on the top and, with the master switch set to STD.B1 the double-contact relay situated under the input plugs may be closed manually by means of a piece of insulating material such as a pencil. If the unit now starts up a new relay can be fitted or the unit can be replaced by a new one and the faulty relay attended to at some more opportune moment.

178. Should no cure, however, be effected there is little more that can be done, other than the examination and cleaning of the commutator and carbon brushes, after which a new unit will have to be fitted if there is no improvement.

L.T. unit starts but not H.T. unit

179. If the L.T. unit starts up but the H.T. unit fails to do so when the master switch on the transmitter is set to TUNE, the cause of the trouble will probably lie in the starter relay, which is energised from the L.T. unit. This is situated underneath the input plug in the H.T. unit and, after removal of the cover, can be closed manually as described above. If the unit then starts, the leads in the two cables connecting the L.T. unit to the H.T. unit and from the plug P₂ of the H.T. unit to the transmitter plug D should be tested individually for continuity as already described. The switch, type J, should be in one of the three transmit positions, that is NORMAL, H.F. ON TRAILING or M.F. ON FIXED, and if correctly placed, then the leads in the four-way cable from it to the transmitter should be tested.

Power units start but no input to transmitter

180. Should both the power units start up but the transmitter not operate, an examination for the presence of L.T. and/or H.T. can be made. The former may be checked by removing the valve cover on the front of the transmitter and observing whether the valve filaments glow, whilst the latter may be tested by measuring the voltage between a P.A. valve anode cap connector and the chassis, when a reading of approximately 1,200 volts should be obtained.

181. If one or both units appear to give no output, new ones should not be fitted until the leads between them and the transmitter have been checked for continuity as already described. It will be observed from fig. 9 and 10 that the L.T. unit is connected to the transmitter *via* the H.T. unit.

182. The absence of keying, as evidenced by a lack of sidetone in the telephones, indicates trouble in the key or its associated leads, which should be checked for continuity and good fitting in their socket block. The key itself may be examined for easy movement and cleanliness of the contacts, a new one being fitted if the old one is in any way suspected. These remarks also apply to the telephones and their leads, which are connected to the same socket block.

183. If radiation is taking place this will be indicated by the external ammeter on the two H.F. ranges, provided the IN CIRCUIT button is pressed. Should no results be obtained, the type J switch should be inspected. The control lever should be checked for ease of movement and the condition of the shrouded plugs should be examined. Owing to the robust construction of this switch it is unlikely to be the cause of much trouble unless it has sustained obvious damage, and therefore renewal should be effected only if further tests produce no result.

184. The aerial cables may be inspected next for damage, and for continuity and good fitting at the sockets which connect up to the type J switch after which the aeriels themselves may be examined, particular attention being paid to the insulators. It is possible that the fault may be in the ammeter, which can be tested very rapidly by disconnecting its two leads and connecting a spare one temporarily in its place.

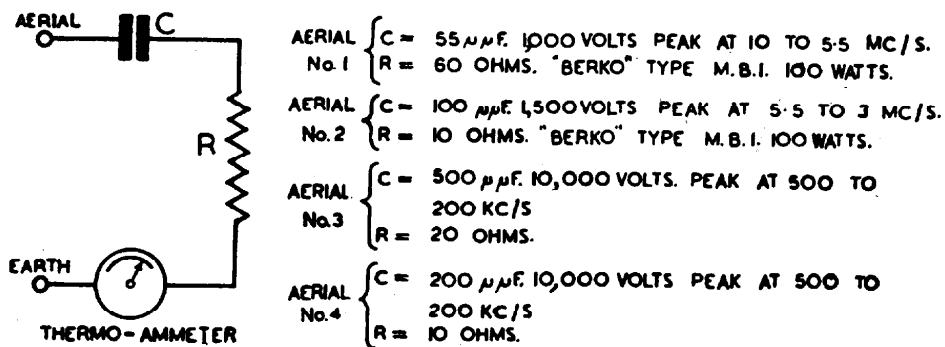

FIG. 22.—DUMMY AERIAL CIRCUIT

Trouble inside transmitter

General

185. After removal from the aircraft the instrument should be withdrawn from its case by unscrewing the ten screws round the outside of the case, three on the right-hand side, five on the left-hand side, one on the top, and one on the bottom. The screws on the front panel do not hold the chassis to the case. An examination should first be made for any obvious faults, either mechanical or electrical, such as damaged variable condensers or inductances, broken connections, blistered resistances and "flash-over" marks on the chassis.

186. The transmitter should now be set up as though for operation in order that further tests may be conducted. Key, phones, L.T. and H.T. units should be connected up to their plugs and sockets. An appropriate dummy aerial should be connected across aerial and earth. If one is not available particulars for making up such a fitting are given in fig. 22. As a temporary measure an ordinary 60-watt lamp may be used on the two H.F. ranges. An aerial approximating to that on the aircraft can be used for final checking after repairs have been effected, but it is inadvisable to use this during testing owing to the wide field of radiation.

187. If the fuse blows repeatedly an examination should be made for a short-circuit between the main H.T. line and chassis. With the power units disconnected and a new fuse fitted a reading

of approximately 27,750 ohms should be obtained between the pin of the H.T. + plug, Plug C, and chassis on the two H.F. ranges; all resistances in the H.T. circuit such as R_3 , R_4 , R_5 , and R_{22} , should be examined for a short-circuit to chassis or signs of overheating, which can be detected by browning or blistering. Condensers, such as C_{13} , C_{14} , C_{15} (only on M.C.W. and R.T.), C_{12} , C_{15} , and C_{16} , should be similarly checked, the easiest method in this case being that of disconnecting them (one end being sufficient except in the case of C_{15} and C_{16}) one by one from the circuit until the reading already given is obtained and the faulty component thus traced.

Transmitter not working on any range

188. If the transmitter is found to be inoperative on all ranges and the relay A/12 cannot be heard to click when the key is pressed, a thorough examination of the relay itself and all associated

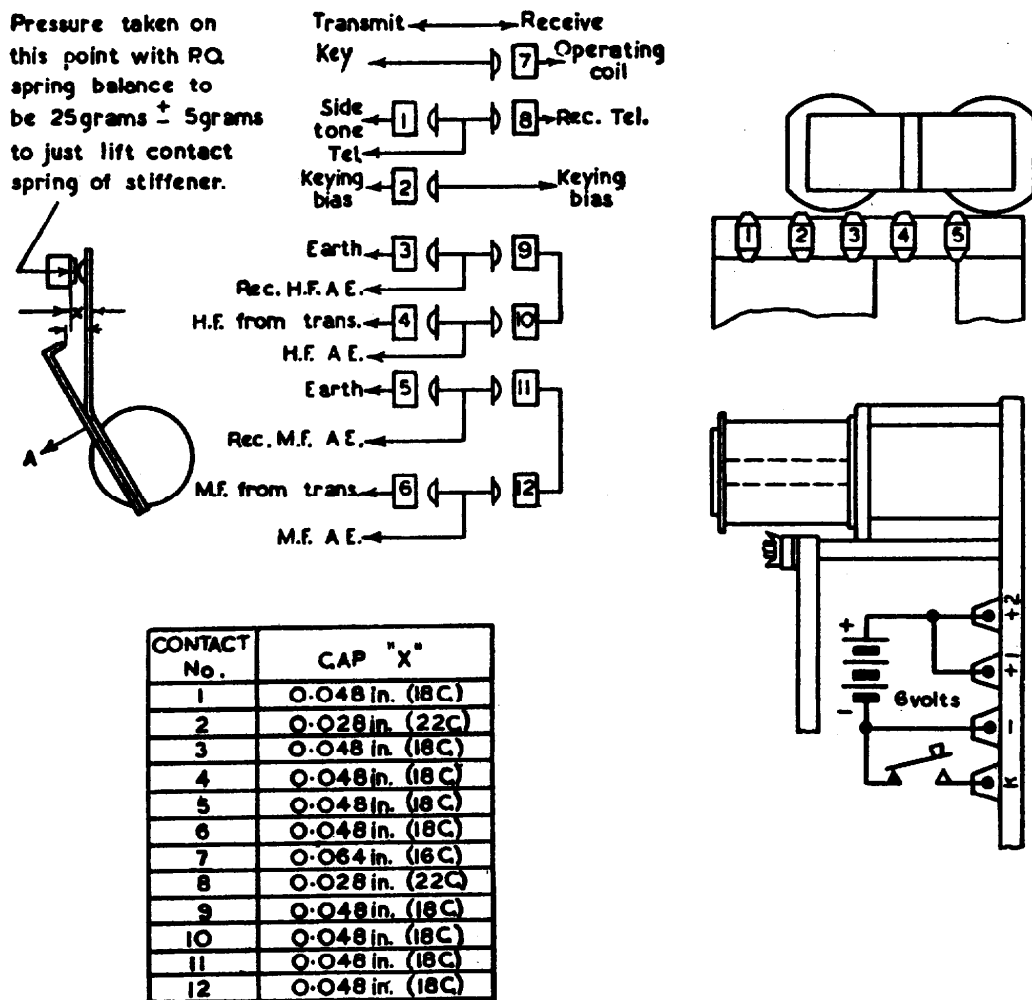

RELAY ADJUSTMENTS

Adjustments are to be made by setting the screw contacts Nos. 1-12 to the required positions as indicated. On no account must the stiffener strips A be bent to facilitate the adjustment. A suitable type of gauge can be made from a 3-in. length of piano wire of the correct diameter; bend the wire at 90° at $\frac{1}{8}$ in. from one end.

COIL TESTS

- Coil A, terminals 3 and 4
- Coil B, terminals 1 and 2
- Coil C, terminals 2 and 5
- Coil C, terminals 2 and K with series resistance

KEYING TEST

Connect battery and key as indicated.

FIG. 23.—ADJUSTMENT AND TESTS OF MAGNETIC RELAY, TYPE 85 (KEYING RELAY)

connections should be made. The wires from the telephone and key plug, Plug B, to the relay should be carefully checked and the relay inspected for mechanical and electrical faults; particulars for gap adjustments and coil tests are given in fig. 23.

189. The relay spindle should swing absolutely freely in its bearings and roll from side to side under its own weight when the relay is tilted. All blade tips and stiffeners should be approximately in line and the pressure between them should be checked by means of a spring gauge (see fig. 23). This should be within the limits of 20 to 30 grams.

190. The coils should be tested for open circuits, the correct terminal test points for each coil being given in fig. 23. These terminal numbers are clearly marked on the relay itself. If any coil is found to have broken down a repair can be effected only if the break is at one of the ends, otherwise either a new coil or a complete relay unit will have to be fitted.

191. After carrying out repairs the resistance of the individual coils may be checked and the following figures should be obtained:—

$$\begin{aligned}\text{Coil A between terminals 3 and 4} &= 12.045\Omega \pm 0.6\Omega \\ \text{Coil B between terminals 1 and 2} &= 1.515\Omega \pm 0.1\Omega \\ \text{Coil C between terminals 2 and 5} &= 2.1\Omega \pm 0.1\Omega\end{aligned}$$

192. The response to keying may also be checked by connecting up a 6 volt supply as indicated in fig. 23.

193. If the relay operates but no reading is obtained on the feed meter M_1 , the meter itself should first of all be checked, the simplest method being that of substitution. The presence of H.T. may next be ascertained by taking the voltage between the top caps of the output valves and chassis when a reading of approximately 1,200 should be obtained. A thorough inspection of the H.T. line should be made if there is no result.

194. All the large clip-in resistances R_3 – R_7 , R_9 and R_{10} at the back of the chassis should be tested; their correct values will be found by reference to the appendix of this chapter. The relay contact clearances should be checked in order to ascertain whether they conform to the particulars given in fig. 23, and if not should be adjusted accordingly. When replacing the resistances in their clips care should be taken to see that the 12,000 + 2,000 ohm one, R_7 , on the right-hand side (looking at the back of the chassis) is correctly inserted, that is with the tap towards the top of the instrument.

195. If the relay operates and a reading is obtained on M_1 but there is an absence of tuning as indicated by the feed meter needle not dipping, a test should be made to find out whether the M.O. stage is working. The M.O. unit is mounted on the right-hand side of the transmitter when viewed from the back, and its operation can be checked by means of a R.F. indicator which can be made up quite simply. A single turn of stoutish covered wire (fairly stiff flex will do) of sufficient diameter to slip comfortably over the M.O. inductances L_1 , L_2 , or L_3 , with a pilot lamp holder connected across the ends is required. This should be fixed to a strip of ebonite or other insulating material (even a piece of wood will answer the purpose) and a 3.5 volt bulb screwed into position in the holder. When this indicator is passed near or over the inductances, a glow from the lamp will show whether the stage is working.

196. If the M.O. is found to be inoperative the H.T. voltage may be checked at the anode pin of the valve holder V_1 . This should vary from 160 approximately on 200 Bc/s to 240 approximately on 10 Mc/s with the master switch in the TUNE, M.C.W., or R/T position; in the c.w. position the readings will be slightly increased. If no readings are obtained the H.T. supply from plug C should be checked through R_8 , the H.F. choke HFC₃, and the inductances L_1 , L_2 , and L_3 . The wiring generally should be examined for loose connections, the resistances R_{10} and R_{11} tested and the condenser C_4 replaced by a new one.

197. All the wiring to the M.O. section of the range switch should be inspected and the switch itself examined for good contact and mechanical damage. In the case of serious trouble, the M.O. unit as a whole can be removed by undoing the seven screws on the front panel, and a new one fitted in its place. A list of M.O. units (drive units) appears in the appendix.

198. If the M.O. is functioning correctly but no output is obtainable, a thorough examination of the output wiring should be made, and the associated section of the range switch inspected. The grid leak R_{12} should be tested and the condenser C_6 replaced. The output inductances should be checked for short-circuited turns, particularly at tapping points, and the rotor vanes of the condensers C_{15} and C_{16} should be examined to see that they run true and are mid-way between the stator vanes. The commutator switch contacts on these two condensers should be checked for contact and also that they are functioning correctly relative to the rotors. The position should be such that a full sweep of the condenser is obtained with the contacts short-circuited or open.

Transmitter not working on one range

199. If the transmitter is found to be inoperative on one range only and the feed meter needle will not dip when tuning is attempted, a test should be made by means of the R.F. indicator referred to in para. 195, to ascertain whether the M.O. circuit of the particular range is working. If not, the M.O. circuit concerned may be generally examined, and in this respect it should be borne in mind that such items as the grid condenser and H.T. feed resistances need not be tested since they are common to all ranges, but the inductance and switch section of the particular range and the connections to them should be checked.

200. If the M.O. is functioning a thorough examination of the output circuit in question should be made. As in the previous paragraph, the remarks regarding components common to all three ranges applies, so that the investigation will consist mostly of an inspection of the range switch section concerned and its associated wiring.

201. If tuning can be effected, as indicated by the feed meter needle dipping, but the aerial will not load up, an inspection should be made of the aerial tap switch and inductance of the range affected. The output panel is on the left-hand side of the instrument, when viewed from the back, with Range 1 and 2 inductance L_4 at the top, Range 3 inductance L_5 in the middle, and the inductance L_6 of the M.F. range at the bottom. Like the M.O. unit, the output unit can, in the event of serious damage, be withdrawn from the main chassis by undoing the six fixing screws on the front panel and the screw holding the lug at the back, and a new one fitted in its place. A list of P.A. units (output units) appears at the end of the appendix.

Modulator trouble

202. Where there is no modulation on M.C.W., as indicated by an absence of sidetone in the telephones when the key is pressed, and no R/T, an examination of the modulator circuit in general will have to be made. This includes the anode resistance R_3 and the choke LFC_2 , as well as the resistances R_{13} and R_{14} ; and the condenser C_{10} should also be inspected.

203. If the transmitter is operating on M.C.W. but there is an absence of R/T, the trouble probably lies in the microphone circuit. The leads from the microphone to its socket in the front panel should be inspected and the windings of the microphone transformer T_1 should be tested for continuity. The microphone link plate at the back of the chassis should be examined to see that the fixings have not become loose and the plate slipped out of its correct position. When using carbon microphones, the polarizing voltage at the microphone sockets should be checked and a reading of 2 volts obtained. If no result is obtained the trouble will lie in the resistances R_{17} , or R_{18} , the primary of T_1 , or possibly in the microphone itself.

204. If M.C.W. and R/T are both operative but there is an absence of sidetone the condenser C_{21} should be replaced by a new one and an inspection of the associated wiring made. The wiring to the relay from plug B should be examined and also the adjustment of the relay contacts as explained in para. 189.

205. Should R/T be working but there is no M.C.W. or sidetone, a renewal of C_7 may be made and the associated wiring carefully checked including an examination of the resistance R_6 and switch contacts.

Point-to-point testing

206. Should the fault still remain reference may be made to the list of point-to-point tests given in the following table. These provide a check as to the correctness of the major part of the wiring, and can be applied not only as a test to an instrument in which repairs have been carried out, but also as a means of localising the trouble in a faulty transmitter. All annotations refer to those in the theoretical circuit diagrams.

TABLE 5
T.1154—Point-to-point Tests

Pin 4 Plug D to Pin 3 Plug D. All positions of S_6 except off	<0.05 Ω
Pin 4 Plug D to Earth. All positions	>5 megohms
Pin 6 Plug D to Pin 3 Socket A	<0.02 Ω
Pin 6 Plug D to keying relay + 1 terminal	<0.02 Ω
Pin 6 Plug D to + fils. V.T.105 valves. All switch positions	<0.02 Ω
Pin 6 Plug D to + fils. V.T.104 valves (except on STD.B1)	<0.02 Ω
Pin 6 Plug D to keying relay + 2 terminal	} All switch positions except off and STD.B1
Pin 6 Plug D to Pin. 13 Plug E	
Pin 5 Plug D to - fils. of valves and earth	<0.02 Ω
Pin 5 Plug D to Pin 4 Socket A	<0.02 Ω
Pin 8 Plug D to Pin 14 Plug E	<0.03 Ω
Pin 1 Plug D to Pin 8 Socket A	<0.02 Ω
Pin 2 Plug D to Pin 7 Socket A	<0.02 Ω
Pin 2 Plug D to Pin 16 Plug E	<0.03 Ω
Pin 15 Plug E to Pin 5 Socket A	<0.03 Ω

TABLE 5—continued

Pin 1 Socket A to H.F. aerial terminals, relay at RECEIVE ...	<2Ω
Pin 2 Socket A to M.F. aerial terminals, relay at RECEIVE ...	<2Ω
Pins 1 and 2 Socket A to earth, relay at SEND ...	<2Ω
Pin 6 Socket A to Pin 16 Plug B, relay at RECEIVE ...	<2Ω
Pin 7 Plug D to R ₁₄ ...	<0.02Ω
H.T. Plug C to feed meter M ₁ ...	0.02Ω
H.T. Plug C to earth, Ranges 1 and 2 ...	27,750Ω
Anode M.O. Valve V.T.105 to H.T. Plug C, H.F. Ranges ...	50,000Ω
Anode M.O. Valve V.T.105 to H.T. Plug C, M.F. ...	25,000Ω
Anode M.O. Valve V.T.105 to earth, M.F. ...	19,000Ω
Cathode M.O. Valve V.T.105 to earth ...	0.02Ω
Grid M.O. Valve V.T.105 to earth ...	20,050Ω
Grid M.O. Valve V.T.105 to Pin 14 Plug B, relay at SEND ...	15,050Ω
Anode Mod. Valve V.T.105 to H.T. Plug C (R ₄ removed) ...	75,000Ω
Cathode Mod. Valve V.T.105 to earth ...	820Ω
Grid Mod. Valve V.T.105 to earth ...	13,000Ω
Anode P.A. Valves V.T.104 to H.T. Plug C, Ranges 1, 2, and 3 ...	50Ω
Suppressor P.A. Valves V.T.104 to earth, TUNE ...	5,350Ω
Suppressor P.A. Valves V.T.104 to earth, c.w. ...	2,000Ω
Suppressor P.A. Valves V.T.104 to earth, m.c.w. ...	10,350Ω
Suppressor P.A. Valves V.T.104 to earth, r/t ...	10,350Ω
Suppressor P.A. Valves V.T.104 to Pin 7 Plug D, TUNE ...	70Ω
Suppressor P.A. Valves V.T.104 to Pin 7 Plug D, c.w. ...	7,000Ω
Suppressor P.A. Valves V.T.104 to Pin 7 Plug D, m.c.w. ...	5,000Ω
Suppressor P.A. Valves V.T.104 to Pin 7 Plug D, r/t ...	5,000Ω
Grid P.A. Valves V.T.104 to earth ...	25,000Ω
Grid P.A. Valves V.T.104 to Pin 7 Plug D, TUNE ...	20,350Ω
Grid P.A. Valves V.T.104 to Pin 7 Plug D, c.w. ...	20,000Ω
Grid P.A. Valves V.T.104 to Pin 7 Plug D, m.c.w. ...	20,350Ω
Grid P.A. Valves V.T.104 to Pin 7 Plug D, r/t ...	20,350Ω
Screens P.A. Valves V.T.104 to junction R ₄ and R ₇ ...	0.03Ω
Screens P.A. Valves V.T.104 to earth ...	14,000Ω
Screens P.A. Valves V.T.104 to H.T. Plug C ...	20,000Ω
Pin 7 Plug D to Pin 14 Plug B. All switch positions except c.w. Relay at SEND ...	350Ω
Pin 7 Plug D to Pin 14 Plug B, c.w., relay at SEND ...	<0.1Ω
Pin 16 Plug B to condenser C ₉ , relay at SEND ...	<0.5Ω
Pin 13 Plug B to KEY on keying relay ...	<0.02Ω
Pin 15 Plug B to earth ...	<0.02Ω
Pin 14 Plug B to Pin 15, relay at SEND ...	5,000Ω
Pin (-) microphone socket to earth ...	<0.02Ω
Pin (+) microphone socket to earth, link at CARBON MICROPHONE, switch at r/t ...	25Ω
Pin (+) microphone to earth, link at E.M. MICROPHONE, switch at r/t ...	7Ω
Pin (+) microphone socket to Pin 6 Plug D, link at CARBON MICROPHONE, switch at r/t ...	29Ω
Across R ₁₇ , on OFF and STD.BI ...	10Ω
Junction R ₁₇ and R ₁₈ to Pin 6 Plug D on TUNE, c.w., m.c.w., and r/t ...	5.5Ω
C ₈ to anode M.O. Valve V.T.105, M.F. Range ...	2.5Ω
C ₈ to C ₉ , M.F. Range ...	510Ω
Across R ₂₈ on RED range ...	150Ω

Insulation resistance

207. The following test of insulation may be carried out, and a reading greater than 5 megohms should be obtained when 500 volts d.c. is applied between points named:—

- Pin 7 Socket A and Pin 8 Socket A
- Pin 5 Socket A and Pin 8 Socket A
- Pin 7 Socket A and Frame
- Pin 8 Socket A and Frame
- Pin 5 Socket A and Frame
- Pin 4 Plug D and Frame (Master switch in all positions).

208. A flash test of the H.T. wiring of the transmitter can also be made and should be carried out in the following manner:—

- (i) All valves must be removed.
- (ii) All large clip-in resistances at the back must be removed.
- (iii) Apply 2,500 volts for one minute between H.T. + pin, plug C, and chassis.

Mechanical inspection

209. Having rectified any fault it is suggested that a mechanical inspection should be made before replacing the instrument in the aircraft, and the following points should be checked.

- (i) All joints are mechanically sound and properly soldered.
- (ii) Moving controls do not foul the wiring, particularly the master switch and relay contacts.
- (iii) All controls touch the stops provided on the panel at the extremes of their movement.
- (iv) Click action on the switch knobs is not masked by friction to such an extent that the tapping points cannot be easily located by feel alone.
- (v) Valves are pushed home in their holders and valve shields are tight on their bases.
- (vi) Meter zero adjustments are correct.
- (vii) All tuning knobs have smooth action throughout their range of movement.
- (viii) Each click stop locates firmly and definitely with not less than 0.020 in. lift of the levers.
- (ix) When the set screw of any particular click ring is released, the knob is free to rotate whilst the click ring remains stationary.
- (x) Range switch has free movement and contacts are making satisfactorily
- (xi) Large resistance clips are not loose on their panel and resistances are not loose in the clips.
- (xii) The tap on the 14000Ω resistance, R₇, R₈, is not touching the side of the case and is not loose on the resistance.
- (xiii) The corona shield on the relay is in position on the M.F. aerial contact.
- (xiv) End play does not allow the edges of the relay armature to rub on the moulding and the armature is free enough to swing by its own weight when the transmitter is tilted.
- (xv) All braided leads are securely fitted to prevent braiding touching other terminals.

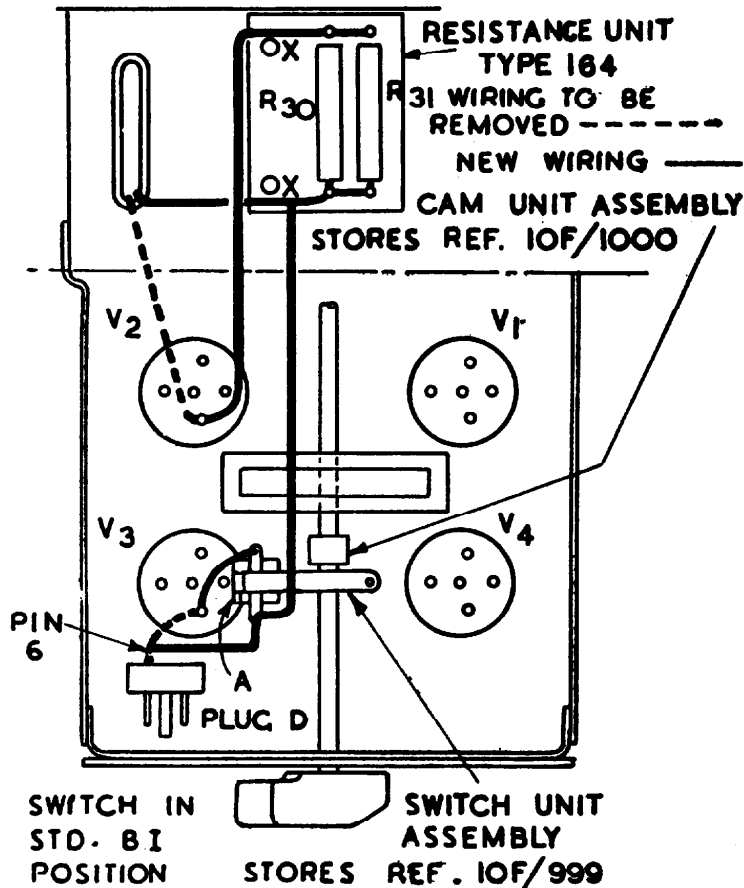

FIG. 24.—FITTING OF RESISTANCES R₃₀ AND R₃₁

MODIFICATIONS TO TRANSMITTERS AND ASSOCIATED EQUIPMENT

Fitting of resistances R₃₀, R₃₁

210. Early transmitters in the T.1154 series were not provided with the parallel resistances R₃₀, R₃₁, which limit the current through the P.A. valve filaments when S₁ is at STD.B1. Later production models included these resistances, and modifications were made by the manufacturers to a wafer of S₁ to provide for their being switched into circuit on STD.B1 only. This is the arrangement shown in fig. 4 and inset in fig. 5.

211. Instructions were also issued to enable units to add the resistances and the associated switching themselves, a cam-operated switch being supplied for fitting to the spindle of S_2 , as shown in the main diagram of fig. 5. The components required are as follows:—

Resistance unit, type 164, Stores Ref. 10W/4606 (comprising resistances R_{20} , R_{21}).

Cam unit assembly, Stores Ref. 10F/1000.

Switch unit assembly, Stores Ref. 10F/999 (comprising the switch contacts operated by the cam unit assembly).

212. The procedure for carrying out the modification in C.W., M.C.W., and R/T transmitters is as follows. These instructions should be read in conjunction with fig. 24. They were promulgated in leaflet A.P.1186/A.162—W.

- (i) Remove the valves from the transmitter.
- (ii) Remove the transmitter from its case, placing it inverted on the bench with the panel to the front. Identify the valve holder compartment.

Mounting of filament resistances

- (iii) Replace the two screws at "X" by two 6 B.A. $\times \frac{1}{4}$ in. cheese-head brass screws.
- (iv) Fit the resistance unit, type 164, to these screws and secure by means of 6 B.A. washers and nuts. Coat the nuts and projecting ends of the screws with shellac varnish.

Mounting of filament switch

- (v) Slacken off the screws of the cam unit assembly and separate the two parts. Place the cam unit on the switch rod as shown with the section containing the two screws underneath. Tighten sufficiently to retain the unit on the switch rod.
- (vi) Fit the switch unit assembly to the valve holder screw A. The switch unit assembly has a tapped hole to accommodate the screw which should be coated with shellac varnish before fitting.
- (vii) Set S_2 to the position engraved STD.BI.
- (viii) Slide the cam unit into position so that the indent in the switch arm blade engages centrally in the groove of the semi-circular cam. Tighten the fixing screws of the cam unit assembly, and coat with shellac varnish.
- (ix) Rotate the switch handle and check that the contacts of the switch unit assembly are closed at all positions except STD.BI. It is also important to check that the contacts are open when the switch handle is rotated to the STD.BI position from either direction.

Modification to wiring of transmitter

- (x) A lead connects from pin No. 6 of the 8-pin plug, type 212 (Stores Ref. 10H/438), to the positive heater socket of the adjacent V.T.104 valve holder V_2 . Disconnect this lead at the valve holder pin and transfer it to the front spill of the switch unit assembly.
- (xi) From this latter tag connect a length of No. 18 s.w.g. tinned copper wire encased in Grade E insulating tubing to one of the lower soldering tags of the resistance unit, type 164. This lead is to pass under any components on the way.
- (xii) Solder an insulated lead between the heater socket referred to in sub-para. (x) and the free soldering tag of the switch assembly unit.
- (xiii) In certain transmitters type T.1154B, a lead which passes through the elongated hole in the back of the compartment connects to a V.T.104 heater socket V_2 as shown. This lead is to be disconnected at the heater socket and re-connected to the lower soldering tag of the resistance unit, type 164.
- (xiv) Connect a suitably insulated lead between the upper soldering tag of the resistance unit, type 164, and the V.T.104 heater socket V_2 as shown.
- (xv) Replace the transmitter in its case and replace the valves and front panel.

Resistance R₇

213. Some issues of the resistance R_7 , type 1046 (Stores Ref. 10W/1046) have the centre tapping clips of such a length that in certain circumstances of rotation of the resistance in its mounting the clip might touch the case of the transmitter.

214. Instructions for remedial measures have been issued in the leaflet A.P.1186/A.139—W. The modification consists in cutting off the surplus length of clip. Care should be taken not to fracture the porcelain tube and to ensure that the screw and nut securing the lead to this clip are still tight after the cutting operation.

M.F. range aerial tuning coil

215. In certain cases the rack-retaining pin on the iron core of the M/F range aerial tuning coil of the transmitter has become loose. This defect can be remedied in the manner described in the leaflet A.P.1186/A.140—W. The following is the sequence of operations:—

- (i) Remove the screws on the top, bottom, and sides of the transmitter, securing the case to the transmitter. Withdraw the transmitter.
- (ii) Identify the M.F. aerial tuning coil control knob, shown as L₆ on fig. 1. Remove the control knob by unscrewing the single fixing screw at its centre.
- (iii) Remove the core retaining strip screwed to the coil former and situated at the back of the transmitter, visible in fig. 11. On removing the fixing screw it may be found to be made from an insulating material; if this is so and it is damaged or broken, it is to be replaced by a 2 B.A. brass screw, cheese head, $\frac{3}{8}$ in. (Stores Ref. 28S/2066).
- (iv) Turn the control spindle in a counter-clockwise direction until the rack is out of mesh with the skew gear wheel. Withdraw the core and rack from the back of the coil.
- (v) Bind linen thread No. 40 (Stores Ref. 32B/456) tightly around the spindle over the pin securing the rack to the core. This should extend about $\frac{1}{8}$ in. on each side of the pin.
- (vi) Cover the linen thread with bakelite or shellac varnish (shellac (Stores Ref. 33A/172) in methylated spirits).
- (vii) Turn the control spindle until the driving pin at the front panel end is horizontal.
- (viii) Engage the core and rack with the skew gear wheel. The rack will require guiding into position and this can be accomplished from the right-hand side of the transmitter. Turn the control spindle clockwise applying slight pressure to the core to ensure that the rack is drawn into mesh.
- (ix) Replace the control knob and check to ensure that the core travels the whole length of the coil with a complete rotation of the control knob between stops. In the fully counter-clockwise position of the control knob, the core should be approximately $\frac{1}{8}$ in. below the back edge of the end of the coil former.
- (x) Remove the control knob. If the core does not travel the whole length of the coil, rotate the knob 180 deg. and replace it.
- (xi) Replace the core retaining strip.
- (xii) Replace the transmitter in the case and secure with the screws previously removed.

Transmitter case screws

216. It has been found that the "coin-slot" 4 B.A. screws securing the transmitter to the case are apt, by continued use, to strip their threads. Units have been instructed in leaflet A.P.1186/A.142—W to replace at the first opportunity, any such stripped screws by the special replacement screws, case securing, coin-slot, $\frac{1}{8}$ in. Whit. (Stores Ref. 10D/590), demanded from the appropriate Maintenance Unit. Before fitting the new screws, the holes have to be tapped out to $\frac{1}{8}$ in. Whit.

Additional element for type 52 resistance

217. To improve heater voltage regulation, instructions have been given for units to connect a resistance type 4773 (Stores Ref. 10W/16125) across terminals 6 and 7 of the resistance unit type 52. Care should be taken to check that this cannot make contact with other elements in the resistance unit. The label on the unit should be amended to read "Resistance Unit Type 52A" (Stores Ref. 10W/16024).

Security of sockets

218. Sockets type 173 (Stores Ref. 10H/423) fitted with an early type of brass insert, are apt, under vibration, to fall out of engagement with the external aerial ammeter used on the H.F. ranges (Stores Ref. 10A/12227). Such inserts can be identified by the fact that they finish about $\frac{1}{4}$ in. short of the moulded socket body. They are to be replaced by new inserts (Stores Ref. 10H/1970). Access to the inserts is obtained by unscrewing the two moulded portions of the socket. The old ones are to be carefully unsweated from the cables and replaced by the new. The socket, when fitted with the new insert, should withstand a pull of 4 lb. as measured by a spring balance.

219. Early issues of sockets type 172 (Stores Ref. 10H/422), type 135 (Stores Ref. 10H/319), and type 136 (Stores Ref. 10H/320) were liable to fall out of the type J-switch under vibration. If the pull required to remove them is less than 4 lb. as tested by a spring balance, the two parts of the moulded socket body are to be unscrewed and an additional spring (Stores Ref. 10H/1971) fitted over the existing one. To re-assemble the socket body it may be necessary to reamer out the central hole in the forepart of the moulded body to allow entry of the insert when fitted with the additional spring. The pull-off should again be tested, and if still unsatisfactory a new socket of the appropriate type demanded. Authority for the above modifications was given in leaflet A.P.1186/E.78—W.

Breakdown of milliammeter type D (T.1154C, F. H, K, and M)

220. Cases have occurred in service where the anode feed meter in the above transmitters has been burned out due to coupling existing between the external connecting leads and the Range 1 amplifier coil. The following procedure for re-positioning the leads was therefore promulgated in leaflet A.P.1186/A.199—W:—

- (i) Withdraw the chassis from its case.
- (ii) Remove the front cover of the valve compartment.
- (iii) Identify the amplifier feed meter (M_1 in fig. 1).
- (iv) From one terminal of the meter, a lead connects to the H.T. fuse. Disconnect this lead from the fuse.
- (v) Remove the four meter securing screws and tilt the meter forward in order to simplify removal of the leads.
- (vi) Remove and discard the lead which connects from one terminal of the meter to the junction of R_{17} and R_{18} .
- (vii) Remove and discard the lead which connects from the fuse to R_{16} .
Note.—The condenser C_{30} is to remain connected across the meter M_1 .
- (viii) Connect one end of each of two leads of 22 s.w.g. tinned copper wire (Stores Ref. 5E/1781), encased in tubing, insulating H.T., grade D (Stores Ref. 5F/1796), to each terminal of the meter.
- (ix) Re-mount the meter in its panel by means of its cover and its four screws.
- (x) Re-connect the lead which was disconnected in operation (iv) to the H.T. fuse.
- (xi) Pass the two leads connected to the meter in operation (viii) through the screening *via* the hole directly beneath the H.T. fuse into and along the roof of the compartment containing the V.T.105 valves. Pass the leads to the rear of this compartment and up through the space between C_{14} and the range switch, under the latter to R_{16} , R_{17} , and R_{18} .
Note.—The lead from the meter terminal which is connected to the H.T. fuse is to be connected to R_{16} ; the remaining lead is to be connected to the junction of R_{17} and R_{18} .
- (xii) Replace the valve compartment cover.
- (xiii) Replace the chassis in its case.

Re-wiring of H.T. fuse

221. It has been found that greater protection can be given to transmitters of all types by transferring the H.T. fuse F_1 from the positive lead to the negative lead. To modify transmitters in which this alteration has not been carried out, the following procedure has been laid down in leaflet A.P.1186/A.197—W:—

- (i) Remove the lead between pin 7 of plug D and R_{24} ($5,100\Omega$ or $4,700\Omega$) in the resistance tray
- (ii) Transfer the H.T. lead from plug C to pin 7 above, shortening as necessary.
- (iii) Connect a lead of 18 s.w.g. tinned copper wire (Stores Ref. 5E/1779), encased in tubing, insulating, grade E (Stores Ref. 5F/1910) from plug C, through the slit in the side of the resistance tray to the bottom end of R_3 ($50,000\Omega$) and R_4 ($20,000\Omega$). Approx. 3 ft. of wire and tubing should be demanded.
- (iv) Remove the lead between the end spill of the fuseholder and the milliammeter. Transfer any other leads from the same fuseholder spill to the milliammeter terminal.
- (v) Connect an insulated lead (see para. (iii)) from the end spill of the fuseholder to the top end of R_{10} (350Ω). The lead will pass under HFC_1 and C_{14} and through the existing hole in the top of the resistance tray; a grommet should be fitted before passing the lead through the hole.

Replacement for resistances R_{11} and R_{12}

222. Should failures occur of the resistance type 1049 (R_{11}) or resistance type 1050 (R_{12}) instructions have been given in leaflet A.P.1186/A.183—W to replace them by the following components:—

Circuit Ref.		Stores Ref.		Nomenclature
R_{11}	10W/1916	...	Resistance type 1916, $15,000\Omega$
R_{12}	10W/56	...	Resistance type 563, $20,000\Omega$

APPENDIX 1

VALUES AND TYPES OF COMPONENTS

CONDENSERS

T.1154C

Annotation, fig. 4	Value	Type	Stores Ref. 10C/
C ₂ , C ₄	11-135 μF	3333	11062
C ₅	-0002 μF	943	2038
C ₆	-0002 μF	943	2038
C ₇	50 μF	944	2039
C ₈	.5 μF	955	2053
C ₉	-001 μF	897 or 1647	965 or 3381
C ₁₀	-0002 μF	946 or 1593	2041 or 3279
C ₁₁	-01 μF	188 or 1503	8496 or 3103
C ₁₂	-004 μF	947	2043
C ₁₃	-01 μF	188 or 1503	8496 or 3103
C ₁₄	-004 μF	948	2043
C ₁₅	7-205 μF	Part of magnifier unit, type 3 (10D/499)	(10D/499)
C ₁₆	7-205 μF		
C ₁₇	22-5-346 μF		
C ₁₈	-005 μF		
C ₁₉	-005 μF	949	2044
C ₂₀	-004 μF	956 or 1502	2055 or 3102
C ₂₁	.5 μF	955	2053
C ₂₂	-0003 μF	950 or 1501	{ 2045 or 3101
C ₂₃	-0003 μF		
C ₂₄	-0003 μF		
C ₂₅	-001 μF	1647	3381
C ₂₆	2 μF	1031	2220
C ₂₇	40 μF	1648	3383
C ₂₈	-0006 μF	1676	3415
C ₂₉	-0006 μF	1676	3415
C ₃₀	-004 μF	1505	3105

T.1154F, H, and K

Condensers are the same as in T.1154C with the following exceptions:—

Annotation, fig. 4	Value	Type	Stores Ref. 10C/
C ₁₀	-0002 μF	178	8388
C ₁₂ , C ₂₀	7-205 μF	Part of magnifier unit, type 6 (10D/943) in T.1154F and K	D/943)
C ₁₃ , C ₁₉	-0045 μF		
C ₂₅	-0034 μF	1502	3102
C ₂₈	-002 μF	3903	11199

T.1154M

Condensers are the same as in T.1154C with the following exceptions:—

Annotation, fig. 4	Value	Type	Stores Ref. 10C/
C ₁₀	-0002 μF	178	8388
C ₁₂ , C ₁₉	-0045 μF	3523	11554
C ₂₂ , C ₂₃ , C ₂₄	-0003 μF	3712	12000
C ₂₅	-001 μF	2195	4250
C ₂₇	40 μF	2007	3938
C ₂₈	-004 μF	1505	3105
C ₂₉	-002 μF	3903	11199

T.1154, T.1154A, B, D, E, and J

Annotation, fig. 5	Value	Type	Stores Ref. 10C/
C ₁	10 μF	942	2018
C ₂	11-135 μF	3333	11062
C ₃	6 μF	976	2086
C ₄	11-135 μF	3333	11062
C ₅	.0002 μF	943	2038
C ₆	.0002 μF	943	2038
C ₇	50 μF	944	2039
C ₈	.25 μF	955	2053
C ₉	.001 μF	897 or 1647	965 or 3381
C ₁₀	.0002 μF	946 or 1593	2041 or 3279
C ₁₁	.01 μF	188 or 1503	8496 or 3103
C ₁₂	.004 μF	947	2043
C ₁₃	.01 μF	188 or 1503	8496 or 3103
C ₁₄	.004 μF	948	2043
C ₁₅	7-205 μF	} Part of magnifier unit, type 1 (10D/106) in T.1154; type 2 (10D/107) in T.1154A, B, J and L; type 4 (10D/736) in T.1154D; Type 5 (10D/737) in T.1154E; and type 7 (10D/2238) in T.1154N	}
C ₁₆	7-205 μF		
C ₁₇	22.5-346 μF	3332	11061
C ₁₈	.005 μF	949	2044
C ₁₉	.005 μF	949	2044
C ₂₀	.004 μF	956 or 1502	2055 or 3102
C ₂₁	.5 μF	955	2053
C ₂₂	.0003 μF	} 950 or 1501	} 2045 or 3101
C ₂₃	.0003 μF		
C ₂₄	.0003 μF		
C ₂₅	.001 μF	1647	3381
C ₂₆	2 μF	1031	2220
C ₂₇	40 μF	1648	3383
C ₂₈	.004 μF	1505	3105

T.1154N

Condensers are the same as in T.1154, T.1154A, B, D, E, and J, with the following exceptions:—

Annotation, fig. 5	Value	Type	Stores Ref. 10C/
C ₅	.5 μF	955	2053
C ₆	.001 μF	2195	4250
C ₇	.0002 μF	178	8388
C ₈	.01 μF	3886	12343
C ₉	.005 μF	3523	11554
C ₁₀	.004 μF	750	518
C ₁₁	.0003 μF	3712	12000
C ₁₂	.001 μF	2195	4250
C ₁₇	40 μF	2007	3938

T.1154L

Condensers are the same as in T.1154, T.1154A, B, D, E, and J, with the following exceptions:—

Annotation, fig. 6	Value	Type	Stores Ref. 10C/
C ₅	6 μF	976	2086
C ₆	.5 μF	955	2053
C ₇	.001 μF	2195	4250
C ₈	.0002 μF	178	8388
C ₉	.01 μF	3886	12343
C ₁₀	.005 μF	3523	11554
C ₁₁	.004 μF	750	518
C ₁₂	.0003 μF	3712	12000
C ₁₇	.001 μF	2195	4250
C ₂₇	40 μF	2007	3938

RESISTANCES

T.1154C

Annotation in fig. 4	Value ohms	Type	Stores Ref. 10W/
R ₁	51,000	868	677
R ₂	51,000	868	677
or R ₁ and R ₂ (one resistance)	24,000	6119	6119
R ₃	50,000	1043	1043
R ₄	20,000	1044	1044
R ₅ , R ₆	75,000	1045	1045
R ₇ , R ₈	12,000 + 2,000	1046	1046
R ₉	5,000	1047	1047
R ₁₀	350	1048	1048
R ₁₁	15,000	1049	1049
R ₁₂	20,000	1050	1050
R ₁₃	680	1053	1053
R ₁₄	7,500	1051	1051
R ₁₅	820	1052	1052
R ₁₆ -R ₁₈	10 + 19.5 + 19.5	1056	1056
R ₁₉ -R ₂₃	10+2.9+5.3+12.6+69.2	1055	1055
R ₂₄	5,100 or	942 or	877 or
	4,700	917	1872
R ₂₅	510	868	677
R ₂₇ , R ₂₈	10 + 6	1054 or	1054
		6833	6833
R ₂₉	150	1931	1931
R ₃₀	1.5	8208	8208
R ₃₁	1.5	8208	8208
R ₃₂	100	1903	1903
R ₃₃	1 M	95	7908

T.1154F, H, and K

Resistances are the same as in T.1154C with the following exceptions:—

Annotation in fig. 4	Value ohms	Type	Stores Ref. 10W/
R ₁	50,000	1042	1042
R ₂	51,000	7211	7211
or R ₁ and R ₂ (one resistance)	24,000 or	6119	6119
	27,000	6839	6839
R ₁₁	15,000	1916	1916
R ₁₂	20,000	563	56
R ₂₄	5,100	6106	6106
R ₂₅	560	868	677
R ₂₉	150	2875	9640
R ₃₂	100	561	53

T. 154M

Resistances are the same as in T.1154C, with the following exceptions:—

Annotation in fig. 4	Value ohms	Type	Stores Ref. 10W/
R ₁ , R ₂	50,000	1042	1042
or R ₁ and R ₂ (one resistance)	24,000 or	6119	6119
	27,000	6839	6839
R ₁₁	15,000	1916	1916
R ₁₂	20,000	563	56
R ₂₄	5,100	942	877
R ₂₅	560	1106	1106
R ₂₉	150	2875	9640
R ₃₀ and R ₃₁ (or may be two resistances of 1.5 ohms as in T.1154C)	.75	2008	8453
R ₃₂	100	498	11635

T.1154, T.1154A, B, D, E, and J

Annotation in fig. 5	Values ohms	Type	Stores Ref. 10W/
R ₁ , R ₂ or R ₁ and R ₂ (one resistance)	51,000 each 24,000	868 6119	677 6119
R ₃	50,000	1043	1043
R ₄	20,000	1044	1044
R ₅ , R ₆	75,000	1045	1045
R ₇ , R ₈	12,000 + 2,000	1046	1046
R ₉	5,000	1047	1047
R ₁₀	350	1048	1048
R ₁₁	15,000	1049	1049
R ₁₂	20,000	1050	1050
R ₁₃	680	1053	1053
R ₁₄	7,500	1051	1051
R ₁₅	820	1052	1052
R ₁₆ -R ₁₈	10 + 19.5 + 19.5	1056	1056
R ₁₉ -R ₂₃	10 + 2.9 + 5.3 + 12.6 + 69.2	1055	1055
R ₂₄	5,100 or 4,700	942 or 917	877 or 1872
R ₂₅	51	934	851
R ₂₆	510	868	677
R ₂₇ , R ₂₈	10 + 6	1054 or 6833	1054 6833
R ₂₉	150	1931	1931
R ₃₀ and R ₃₁	1.5	8208	8208

T.1154L and N

Resistances are the same as in the T.1154, T.1154A, B, D, E, and J, with the following exceptions:—

Annotation, fig. 5	Value ohms	Type	Stores Ref. 10W/
R ₁ , R ₂ or R ₁ and R ₂ (one resistance)	50,000 each 24,000 or 27,000	1042 6119 6834	1042 6119 6834
R ₄	20,000	306	9820
R ₁₁	15,000	1916	1916
R ₁₂	20,000	563	56
R ₂₅	560	1106	1106
R ₂₉	150	2875	9640
R ₃₀ , R ₃₁ or R ₃₀ and R ₃₁ (one resistance)	1.5 each .75	8208 2008 or 2007	8208 8453 8452

CHOKES, H.F. AND L.F.

T.1154B, D, F, H, J, K

Annotation in fig. 4 or 5	Value	Type	Stores Ref. 10C/
HFC ₁	8.8mH	70	578
HFC ₂	1.5mH	86	2054
HFC ₃	15.5mH	200	3809
LFC ₂	1H	49	582
LFC ₃	.325H	71	2289

T.1154

Annotation in fig. 5	Value	Type	Stores Ref. 10C/
HFC ₁	8.8mH	88	2087
HFC ₂	1.5mH	86	2054
LFC ₂	1.21 - .99H	46	579
LFC ₃	.8 - .5H	48	581

T.1154A and E

Annotation in fig. 5	Value	Type	Stores Ref. 10C/
HFC ₁	8.8mH	70	578
HFC ₂	1.5mH	53	79
* LFC ₁	.22H	47	580
LFC ₃	1H	49	582

T.1154L and N

Annotation in fig. 5 or 6	Value	Type	Stores Ref. 10C/
HFC ₁	8.8mH	70	578
HFC ₂	1.5mH	53	79
LFC ₂	1H	49	582
LFC ₃	.325H	71	2289

T.1154C and M

Annotation in fig. 4	Value	Type	Stores Ref. 10C/
HFC ₁	8.8mH	88	2087
HFC ₂	1.5mH	53	79
LFC ₂	1.21 - .99H	46	579
LFC ₃	.8 - .5H	48	581

* Choke LFC₁ is fitted only in transmitters without R/T, and is connected between grid and cathode of the modulator valve, V₄, in place of the secondary of the microphone transformer.

DRIVE AND OUTPUT UNITS

Transmitter	Drive unit Type	Stores Ref. 10D/	Output unit Type	Stores Ref. 10D/
T.1154	2	117	2	108
T.1154A, B	7	521	8	12140
T.1154C	6	495	7	498
T.1154D	13	732	10	738
T.1154E	14	733	11	739
T.1154F	20	1910	23	1553
T.1154H	30	1973	34	1965
T.1154J	31	1974	35	1966
T.1154K	32	1975	36	1967
T.1154L	33	1976	37	1968
T.1154M	34	1977	38	1969
T.1154N	35	1978	39	1970

CHAPTER 2

RECEIVERS, Types R.1155, R.1155A, B, C, D, E, F, L, M, and N

LIST OF CONTENTS

	<i>Para.</i>
Introduction	1
Facilities	2
Power supplies	3
Aerials	5
General description	6
Frequency range switch	7
Master switch	8
Communications circuits R.1155 and R.1155D—	
Aerial connections	10
R.F. amplifier stage	11
Frequency-changer stage	13
I.F. stages	16
Detector and output stages	17
Manual volume control	19
Automatic volume control	22
Beat frequency oscillator	27
Tuning indicator	28
Communications circuits, other versions—	
R.1155A, E, and M... ..	30
R.1155B and F	32
R.1155C	33
R.1155L and N	34
The direction-finding circuits	36
General principles	38
L.F. oscillator for D.F. switching	
Aerial switching	41
Visual indicator switching	43
Meter amplitude	46
The diode limiter valve	48
Visual indicator balancing circuit	50
Visual sense determination	52
Aural D.F.	53
Constructional details	54
Front panel controls	55
Chassis layout	61
Installation	66
Receiver position	67
Power unit position	68
Aerial switch position	69
D.F. loop aerial and impedance matching	70
Fixed aerial input	76
The visual indicator, type 1	77
Setting up the D.F. loop	79
Loop centre tap	80
Navigator-operated receivers	82
Power units	88
Operation	89
Controls	91
Setting up heterodyne oscillator	93
Back-tuning	94
Normal communication	96
D.F. bearings using visual indicator	97
Homing, using visual indicator	100
Aural D.F.	104
Precautions and servicing—	
Ground testing	107
Starter trolley batteries	111
Visual indicator	112
Trouble location	114
Test apparatus	115
Valve data	116
Valve identification	117
Valve replacements	118
Removal of B.F.O. valve	119
Prevention of frequency drift	120
Alignment of incorrectly calibrated receivers	121
Periodic inspections	126
Associated equipment	Appendix 1
List of principal components... ..	Appendix 2

LIST OF ILLUSTRATIONS

	<i>Fig.</i>
Receiver R.1155N	1
Schematic diagram	2
R.1155 and R.1155D circuit diagram with modifications for R.1155A, R.1155E, and R.1155M ...	3
R.1155B and R.1155F circuit diagram	3A
R.1155L and R.1155N circuit diagram	4
Simplified communications circuit	5
I.F. response curve	6
A.F. filter characteristics	7
Biasing and feed arrangements	8
Input/output characteristics	9
Simplified visual D.F. circuit	10
A.F. oscillator switching circuit	11
Visual indicator switching circuit	12
Simplified visual indicator switching circuit	13
Polar diagrams	14
R.1155 chassis, upper deck	15
R.1155 chassis, underside	16
Components location diagram	17
R.1155B chassis, upper deck	18
R.1155B chassis, underside	19
Valve connections	20
Typical installation diagram	21
Plug, type 209	22
Trouble location chart—Communications circuits	23
Trouble location chart—D.F. Switching circuits	23A
The impedance matching units, types 12, 13, and 15	24
Visual indicator, type 1	25

CONCISE DETAILS OF RECEIVERS, Types R.1155, R.1155A, B, C, D, E, F, L, M, and N

Purpose of Equipment	Designed for use in aircraft with transmitters of the T.1154 class. Also used in some A.S.R. launches, radio vehicles, and ground installations. Provides communications and direction-finding facilities.																																				
Type of Wave	C.W., M.C.W., and R.T.																																				
Frequency Range	18.5 Mc/s to 3.0 Mc/s 1,500 kc/s to 600 kc/s 500 kc/s to 75 kc/s All versions use an I.F. of 560 kc/s																																				
			<i>Types R.1155L and N only</i> 18.5 Mc/s to 600 kc/s 500 kc/s to 200 kc/s																																				
Maximum Sensitivity	Input of 10 micro-volts at 210 kc/s gives output in excess of 50 milliwatts Input of 9 micro-volts at 16 Mc/s gives an equivalent output																																				
Selectivity	Approximately 4 kc/s to 6 kc/s total bandwidth for 6 db attenuation																																				
Output Impedance	5,000 ohms																																				
Valves	<table border="0"> <thead> <tr> <th><i>Function</i></th> <th><i>Description</i></th> <th><i>Type</i></th> <th><i>Stores Ref.</i></th> </tr> </thead> <tbody> <tr> <td>Visual D/F switching</td> <td>Two triode-hexodes</td> <td>V.R.99A</td> <td>10E/757</td> </tr> <tr> <td>R.F. amplifier</td> <td>Variable-mu pentode</td> <td>V.R.100</td> <td>10E/278</td> </tr> <tr> <td>Frequency-changer</td> <td>Triode-hexode</td> <td>V.R.99</td> <td>10E/277</td> </tr> <tr> <td>I.F. amplifier</td> <td>Two variable-mu pentodes</td> <td>V.R.100</td> <td>10E/278</td> </tr> <tr> <td>A.V.C. and B.F.O.</td> <td>Double diode triode</td> <td>V.R.101</td> <td>10E/280</td> </tr> <tr> <td>Speech diode, visual meter limiter and output</td> <td>Double diode triode</td> <td>V.R.101</td> <td>10E/280</td> </tr> <tr> <td>Visual meter switching</td> <td>Double triode</td> <td>V.R.102</td> <td>10E/279</td> </tr> <tr> <td>Tuning indicator</td> <td></td> <td>V.I.103</td> <td>10E/305</td> </tr> </tbody> </table>	<i>Function</i>	<i>Description</i>	<i>Type</i>	<i>Stores Ref.</i>	Visual D/F switching	Two triode-hexodes	V.R.99A	10E/757	R.F. amplifier	Variable-mu pentode	V.R.100	10E/278	Frequency-changer	Triode-hexode	V.R.99	10E/277	I.F. amplifier	Two variable-mu pentodes	V.R.100	10E/278	A.V.C. and B.F.O.	Double diode triode	V.R.101	10E/280	Speech diode, visual meter limiter and output	Double diode triode	V.R.101	10E/280	Visual meter switching	Double triode	V.R.102	10E/279	Tuning indicator		V.I.103	10E/305
<i>Function</i>	<i>Description</i>	<i>Type</i>	<i>Stores Ref.</i>																																				
Visual D/F switching	Two triode-hexodes	V.R.99A	10E/757																																				
R.F. amplifier	Variable-mu pentode	V.R.100	10E/278																																				
Frequency-changer	Triode-hexode	V.R.99	10E/277																																				
I.F. amplifier	Two variable-mu pentodes	V.R.100	10E/278																																				
A.V.C. and B.F.O.	Double diode triode	V.R.101	10E/280																																				
Speech diode, visual meter limiter and output	Double diode triode	V.R.101	10E/280																																				
Visual meter switching	Double triode	V.R.102	10E/279																																				
Tuning indicator		V.I.103	10E/305																																				
Power Input	Omni and A.V.C. approx. 45 watts Visual D.F. approx. 50 watts																																				
Power Output	Max. 200 milliwatts into 5,000 ohms impedance																																				
Stores Ref.	R.1155, 10D/98; R.1155A, 10D/820; R.1155B, 10D/13045; R.1155C, 10D/1105; R.1155D, 10D/1331; R.1155E, 10D/1332; R.1155F, 10D/1333; R.1155L, 10D/1477; R.1155M, 10D/1597; R.1155N, 10D/1667																																				
Approx. Overall Dimensions			<table border="0"> <thead> <tr> <th><i>Length</i></th> <th><i>Width</i></th> <th><i>Height</i></th> </tr> </thead> <tbody> <tr> <td>16 $\frac{1}{16}$ in. ...</td> <td>9 $\frac{3}{8}$ in. ...</td> <td>11 $\frac{3}{8}$ in.</td> </tr> </tbody> </table>	<i>Length</i>	<i>Width</i>	<i>Height</i>	16 $\frac{1}{16}$ in. ...	9 $\frac{3}{8}$ in. ...	11 $\frac{3}{8}$ in.																														
<i>Length</i>	<i>Width</i>	<i>Height</i>																																					
16 $\frac{1}{16}$ in. ...	9 $\frac{3}{8}$ in. ...	11 $\frac{3}{8}$ in.																																					
Weight	Aluminium versions approx. 26 lb. Steel versions approx. 32 lb.																																				
Associated Equipment	Transmitters, T.1154 series Resistance units, types 47 and 52 and 52A Aerial switch unit, type J Visual indicator, type 1 Impedance matching units, type 12, 13 or 15 Power units, types 32, 32A, 32B, 33, 33A, 33B, 34, 34A, 35, 35A, 114, 115, 268, and 380																																				

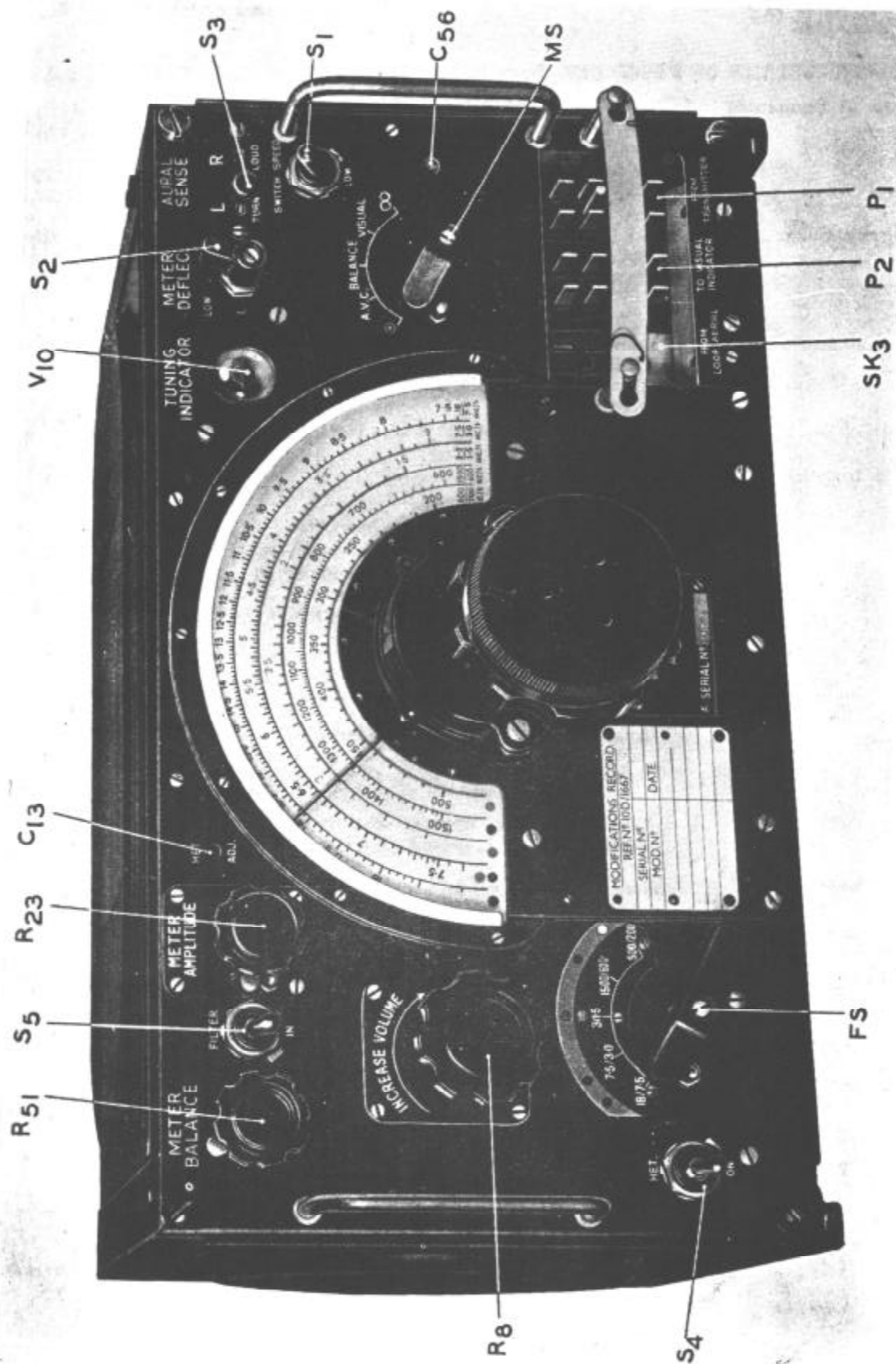

FIG. 1.—RECEIVER R.1155N

CHAPTER 2

RECEIVERS, Types R.1155, R.1155A, B, C, D, E, F, L, M, and N

INTRODUCTION

1. The receivers of the R.1155 class have been designed primarily for use in aircraft, in conjunction with transmitters of the T.1154 class described in Chapter 1 of this publication. A separate publication (A.P.2548B) deals with the installation of the receivers R.1155L and R.1155N in Air-sea rescue launches. The parent type is the receiver R.1155, and later developments are indicated by the use of a suffix letter. The main points of difference are shown in the following table:—

Receiver type	Type of case	Remarks	Frequency coverage	
R.1155	Aluminium	—	18.5 Mc/s to 3 Mc/s 1,500 kc/s to 600 kc/s 500 kc/s to 75 kc/s	
R.1155D	Steel			
R.1155A	Aluminium	Filters fitted to prevent interference from M.F. transmitters (R.1155M is for use only at ground schools)		
R.1155E	Steel			
R.1155M	Aluminium			
R.1155B	Aluminium	As A or E, but H.F. chokes added to prevent interference from radar transmitters		
R.1155F	Steel			
R.1155C	Aluminium	As A, but modified for H.F. D.F. Obsolete		
R.1155L	Aluminium	As B or F, but frequency ranges altered		18.5 Mc/s to 600 kc/s
R.1155N	Steel			500 kc/s to 200 kc/s

Facilities

2. Provision is made for the reception of signals over a wide frequency band which is covered in five ranges. These ranges are as follows:—

Range No.	Receivers R.1155 and R.1155A, B, C, D, E, F, M	Receivers R.1155L and R.1155N
1 (H.F.)	18.5 Mc/s to 7.5 Mc/s	18.5 Mc/s to 7.5 Mc/s
2 (H.F.)	7.5 Mc/s to 3.0 Mc/s	7.5 Mc/s to 3.0 Mc/s
2A (H.F.)	not applicable	3.0 Mc/s to 1.5 Mc/s
3 (M.F.)	1,500 kc/s to 600 kc/s	1,500 kc/s to 600 kc/s
4 (M.F.)	500 kc/s to 200 kc/s	500 kc/s to 200 kc/s
5 (M.F.)	200 kc/s to 75 kc/s	not applicable

Modulated and unmodulated signals can be received on all ranges. Direction finding and homing on certain ranges (mentioned in para. 36) may be carried out by aural or visual means.

Power supplies

3. Detailed descriptions of the airborne power units are given in A.P.1186D, Vol. I, Sect. 8, and the ground power units are described in A.P.1186E, Vol. I, Sect. 6. When airborne, the power supplies are provided by a rotary transformer power unit driven from the aircraft electrical system. This power unit is also the L.T. supply for the associated transmitter of the T.1154 class. Switching on and off the receiver power supplies of a T.1154/R.1155 installation is normally effected by the transmitter master switch. The several types of power unit available for inputs of 12 volts and 24 volts are listed in para. 88 of this chapter.

4. For ground installations, a power unit type 114 may be used. This operates directly from 230-volt 50 c/s mains. Alternatively, a power unit type 115 may be used to provide, from 230-volt 50 c/s mains, the input for the power unit type 34, or 34A. On mobile installations, e.g., W.T. portable stations and radio vehicles, the L.T. supply is usually from accumulators and the H.T. supply from a power unit type 380.

Aerials

5. The receivers may be worked on either fixed or trailing aerials for communications; a fixed aerial, is normally used for the H.F. ranges, and a trailing aerial for the M.F. ranges. A suitable loop aerial, such as type 3, is required for direction finding purposes. Aerial switching is interlocked with that of the associated transmitter by a separate switching device, normally the aerial switching unit, type J. In some installations an aerial plug board may be used instead of the type J switch.

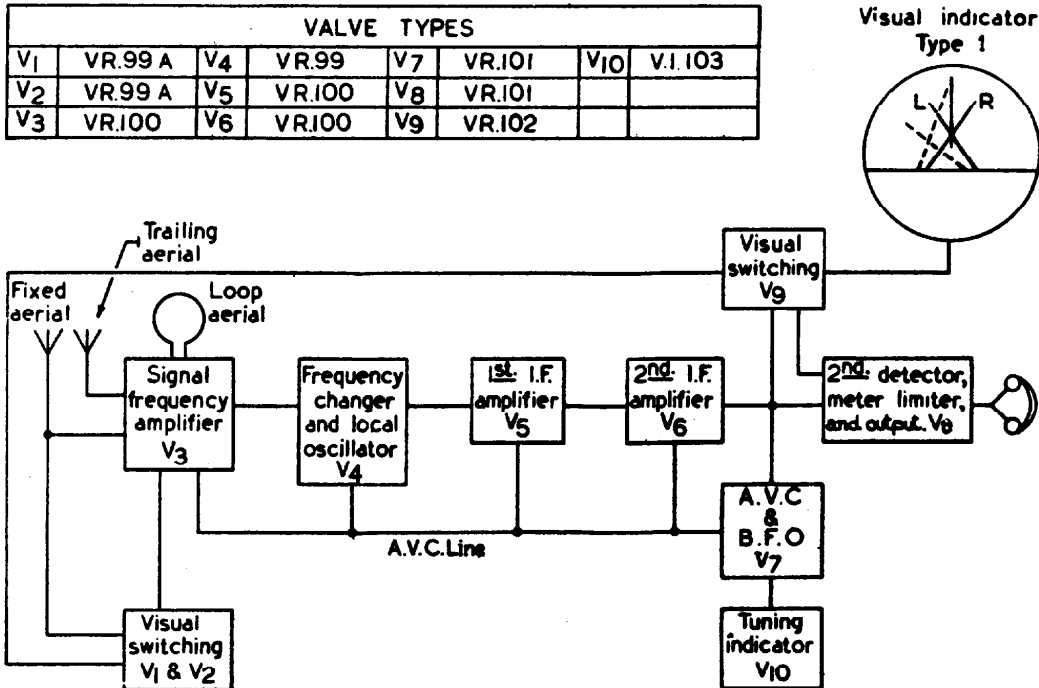

FIG. 2.—SCHEMATIC DIAGRAM

GENERAL DESCRIPTION

6. A ten-valve super-heterodyne circuit is employed, a schematic diagram of which is shown in fig. 2. The communications circuit comprises the valves V₃, V₄, V₅, V₆, V₇, V₈, and V₁₀. For direction finding the valves V₁, V₂, and V₉ are brought into use. The triode-hexode valves V₁ and V₂ electronically switch the input from the H.F. aerial into phase and antiphase relationship with the loop aerial at a predetermined frequency. Valve V₉ switches the rectified output to a visual indicator, type 1, in synchronism with the aerial switching. The input to the visual indicator is limited by one of the diode portions of the double-diode-triode valve V₈. More detailed information is given in paras. 7 to 53, which should be read in conjunction with figs. 3 to 14.

Note.—Paras. 10 to 29 deal with the basic communications circuit of the R.1155 and R.1155D (fig. 3). Variations in the communications circuits of later types are dealt with in paras. 30 to 35. In later sections of the chapter variations in different types are dealt with as they arise.

Frequency range switch

7. This switch is designated FS on the circuit diagrams and illustrations in this chapter. It is an Oak-pattern switch with four wafers, each having front and rear contacts. In the diagrams the individual wafers are annotated "w", "x", "y", and "z", with "f" or "r" added to indicate respectively the "front" or "rear" section of the wafer. Thus FS_{xf} indicates the front section of wafer "x" of the frequency range switch. The functions of this switch are to select the appropriate aerial for the range in use, to select the correct coils for the grid and anode circuits of the R.F. amplifier valve V₃ and the R.F. oscillator portion of the triode-hexode valve V₄, and to regulate the grid bias on the H.F. ranges to preserve constant amplification. The individual wafers involved are "w" (loop aerial input and grid bias adjustment), "x" (aerial and grid coils of valve V₃), "y" (anode coils of valve V₃ and grid coils of hexode portion of valve V₄) and "z" (grid and anode coils of triode portion of valve V₄).

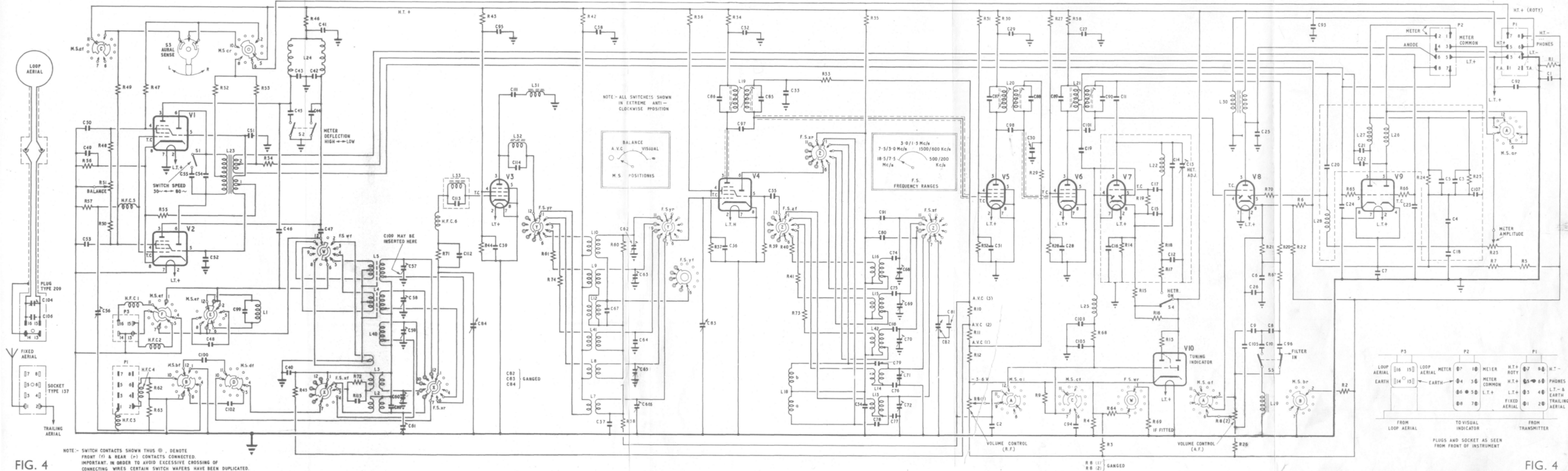
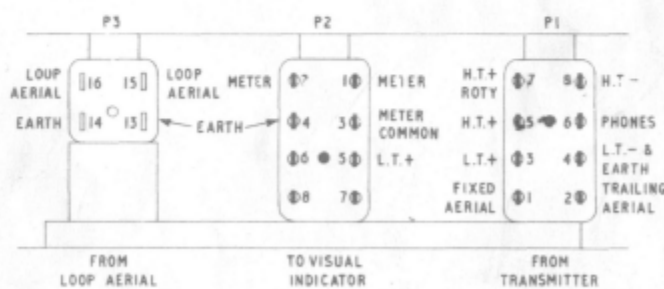

FIG. 4

NOTE - SWITCH CONTACTS SHOWN THUS @, DENOTE FRONT (f) & REAR (r) CONTACTS CONNECTED. IMPORTANT. IN ORDER TO AVOID EXCESSIVE CROSSING OF CONNECTING WIRES CERTAIN SWITCH WAFERS HAVE BEEN DUPLICATED.

PP8670 42751/6443 4/60 500 C & P Gp. 924 (4)

R 1155 L and R 1155 N circuit diagram



PLUGS AND SOCKET AS SEEN FROM FRONT OF INSTRUMENT

FIG. 4

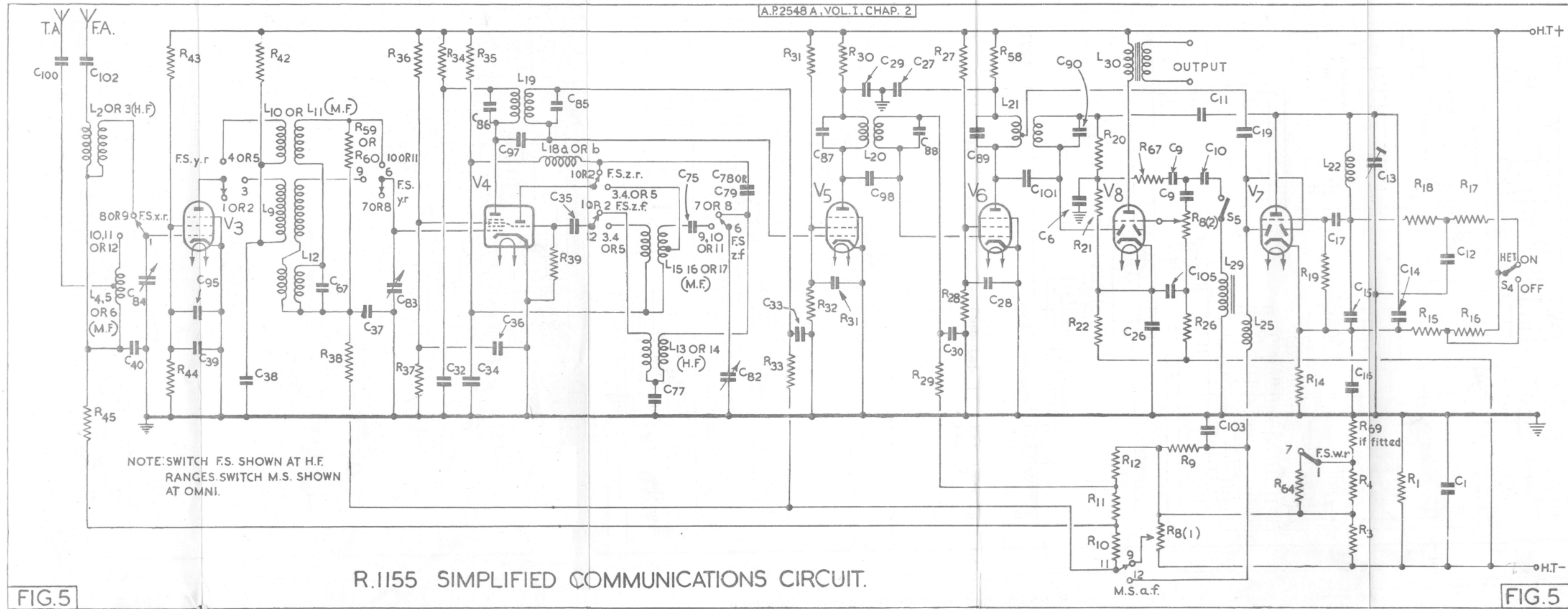

FIG.5

R.1155 SIMPLIFIED COMMUNICATIONS CIRCUIT.

FIG.5

Master switch

8. This switch is designated MS on the circuit diagrams and illustrations, and the wafer sections are denoted by subscripts used in the same manner as already described for the frequency range switch. There are five wafers, "a" (visual indicator, and manual and automatic volume control switching), "b" (fixed and trailing aerial circuits, and D.F. biasing), "c" (D.F. switching valves), "d" (communications aerial input) and "e" (loop aerial).

9. The five positions of the master switch provide the following facilities:—

- (i) \odot ("OMNI") .Normal reception for communications purposes. The gain of the R.F. amplifier, frequency-changer and I.F. stages is manually controlled by a potentiometer $R_{8(1)}$. The A.V.C. circuit is inoperative.
- (ii) A.V.C. The automatic volume control operates on the R.F. amplifier, frequency-changer and I.F. stages. Manual volume control is by the potentiometer $R_{8(2)}$, which controls the audio input to the output stage.
- (iii) BALANCE. This position is used when balancing the two needles of the visual indicator used for D.F. purposes to allow for slight differences in the constants of the switching valves and associated circuits.
- (iv) VISUAL. The visual indicator circuits, including valves V_1 , V_2 , and V_3 are switched into circuit. A.V.C. is provided.
- (v) ∞ ("FIGURE-OF-EIGHT"). In this position bearings may be taken aurally, using the switch S_1 for the determination of sense. A.V.C. is disconnected.

COMMUNICATIONS CIRCUITS, R.1155 and R.1155D

Aerial connections

10. The fixed aerial is connected to pin 1 of the 8-pin plug P_1 , and the trailing aerial to pin 2 of the same plug. The fixed resistors R_{82} and R_{83} are connected across the aerials and earthed at their junction to provide leaks to prevent static charges accumulating on the aerials.

R.F. amplifier stage

11. The communications circuit commences at the R.F. amplifier stage, the basis of which is a variable- μ H.F. pentode valve V_3 . For ranges 1 and 2 the fixed aerial is connected through the condenser C_{102} and coil L_2 or L_3 to the control grid of V_3 . Similarly, the trailing aerial is connected through condenser C_{100} and coil L_4 , L_5 , or L_6 on ranges 3, 4, and 5. Switch sections MS_{bf} , MS_{df} , FS_{2f} and FS_{2r} perform the necessary switching. On all ranges the coils are tuned by a variable condenser C_{44} , which is ganged with condensers C_{83} and C_{82} , for ease of operation. Each grid coil has a pre-set trimmer condenser. These condensers are numbered C_{47} to C_{61} , and in addition C_{116} is used on range 1 (coil L_2) and in certain circumstances C_{100} is fitted on range 5 (coil L_6).

12. The variable- μ characteristic of the valve V_3 enables the gain to be controlled by varying the grid bias. In certain positions of the master switch this is done manually, and in others automatic volume control is provided. The screen voltage of V_3 is obtained from a potential divider comprising the resistors R_{43} , R_{44} , and R_1 . Associated with these are the by-pass condensers C_{95} , C_{39} , and C_1 . Bias for the control grid of the valve V_3 is provided by a resistance network in the A.V.C. circuit. By returning this network to the junction of R_3 and R_4 , which are across R_1 , a standing negative bias of 3.6 volts is provided during no-signal periods.

Frequency-changer stage

Hexode section

13. The triode-hexode valve V_4 operates as a frequency-changer. The output of the R.F. amplifier stage is inductively coupled to the signal grid of the hexode portion by one of the R.F. transformers L_7 , L_8 , L_9 , L_{10} or L_{11} . Selection of the appropriate circuit for each range is made by the switch sections FS_{7f} and FS_{7r} . On all ranges the tuning of the grid circuit is effected by the variable condenser C_{23} . The secondary of each R.F. transformer is trimmed by one of the pre-set condensers C_{63} to C_{66} . A coil L_{15} and condenser C_{67} form a filter tuned to the I.F. of 560 kc/s. This filter is included in the circuit on ranges 3, 4, and 5, to eliminate possible instability due to feedback at the I.F.

14. The incoming signal frequency is admitted at the signal grid G_1 of the hexode portion. The screen grids G_2 and G_3 are connected and form a screening electrode for the injector grid which is internally joined to the grid of the triode portion. This triode functions as an R.F. oscillator at a frequency greater than the signal frequency by 560 kc/s. The signal and oscillator frequencies are

electronically mixed in the hexode portion and voltages at the difference frequency (560 kc/s) are developed across the anode load, which consists of the coil L_{10} and the condenser C_{96} . The screen derives its voltage from the potential divider comprised of R_{36} , R_{37} , and R_1 , with the associated condensers C_{36} and C_1 .

Triode section

15. The triode section of the valve operates as an R.F. oscillator and consists of a tuned anode circuit loosely coupled to an untuned grid circuit. The grid windings of the coils L_{13} , L_{14} , L_{15} , L_{16} , and L_{17} are selected for each range by the switch FS_{gr} . The anode windings of L_{13} to L_{17} are similarly switched into the anode circuit by switch sections FS_{gr} and FS_{af} . On ranges 3, 4, and 5 the oscillator is series-fed, the anode being connected to a tap on the secondary of the coil L_{15} , L_{16} , or L_{17} . On ranges 1 and 2 the oscillator is parallel-fed through the choke L_{16a} or L_{16b} and coupling condenser C_{78} or C_{79} . L_{16a} and L_{16b} resonate at a frequency just below the lowest frequency in their respective bands. Each tuned circuit is tracked to the signal circuits with pre-set parallel trimming condensers C_{68} to C_{72} , and fixed series padding condensers C_{73} to C_{77} . C_{81} determines the minimum capacitance of C_{82} .

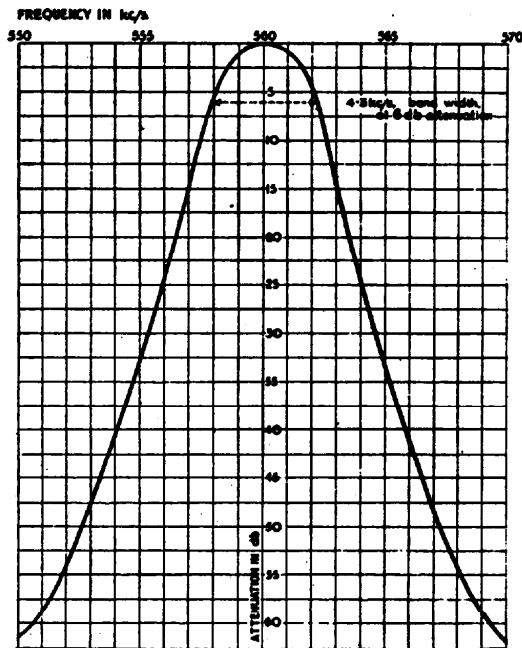

FIG. 6.—I.F. RESPONSE CURVE

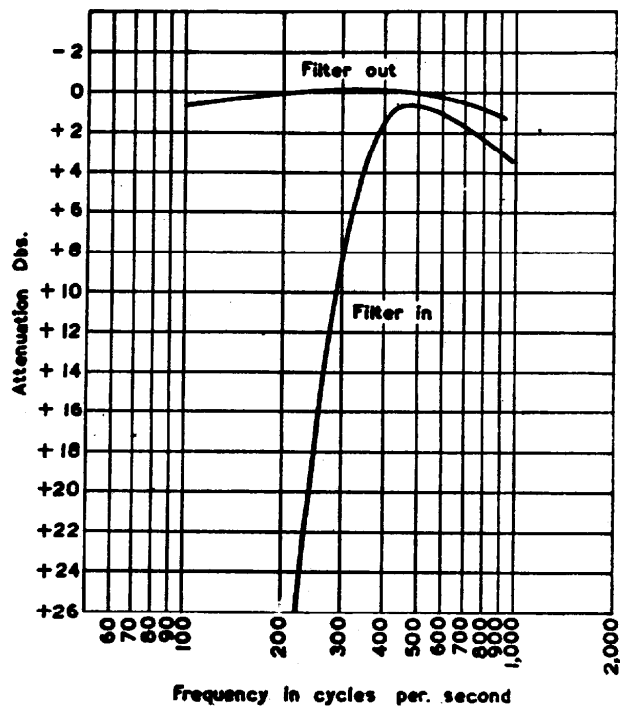

FIG. 7.—A.F. FILTER CHARACTERISTICS

I.F. stages

16. The receiver includes two stages of I.F. amplification employing three band-pass coupling units. The peaked response of this coupling is shown in the curve in fig. 6. Very little inductive coupling exists between the tuned circuits of the band-pass units, the coupling being effected by the small condensers C_{97} , C_{98} , and C_{101} . The coils are adjusted to the I.F. of 560 kc/s by means of iron-dust cores. The primary of the first I.F. transformer, with its associated fixed condenser C_{88} forms the anode load of the hexode portion of the valve V_4 . Decoupling is effected by the resistor R_{34} and condenser C_{33} . The secondary is connected as the grid circuit of V_5 , the resistor R_{35} and condenser C_{33} providing decoupling of the grid bias. The two I.F. valves, V_5 and V_6 , are variable-mu H.F. pentodes, and on A.V.C. their control grids are biased to full and one-tenth A.V.C. voltages respectively. The I.F. transformer units between V_5 and V_6 and between V_6 and V_8 are similar to that already described for the V_4 - V_5 coupling.

Detector and output stages

17. The output from the I.F. amplifier valve V_6 passes to the I.F. transformer unit L_{21} and is taken to one diode of a double-diode-triode valve V_8 . This diode acts as a detector, and the triode section functions as the output valve. The use of a second diode will be dealt with in describing the D.F. circuits (see para. 48). The rectified voltage from the diode detector is developed across two resistors R_{20} and R_{21} . The resistor R_{20} , in conjunction with a condenser C_6 , forms part of a

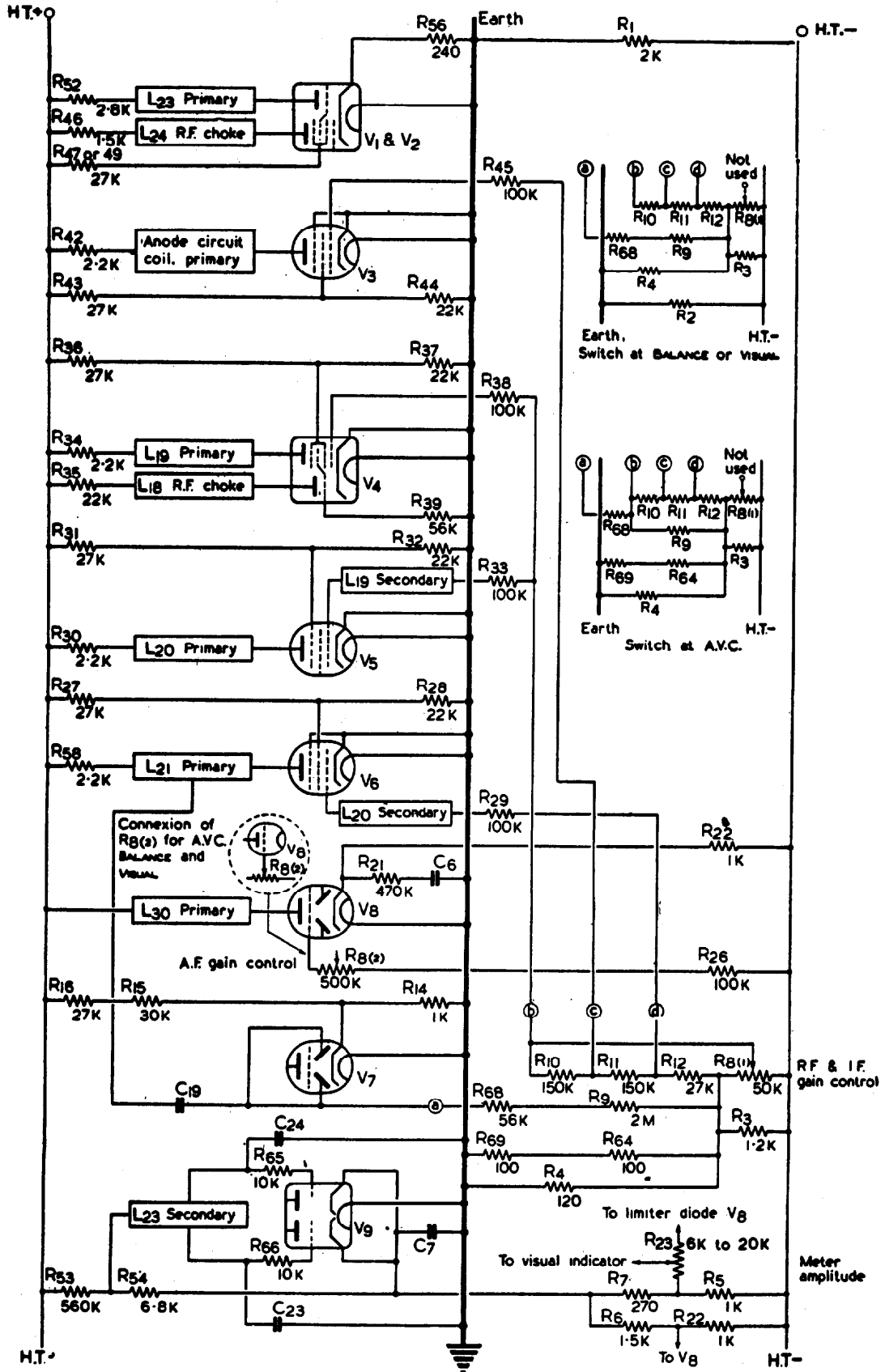

FIG. 8.—BIASING AND FEED ARRANGEMENTS

R.F. filter system to prevent R.F. being passed to the A.F. circuit. A condenser C_{10} with R_{22} decouples the cathode. The A.F. passes through a network comprising the resistor R_{17} and two series condensers C_2 and C_3 to a potentiometer $R_{12(a)}$, the moving contact of which is connected to the grid of the valve V_6 . The voltage developed across $R_{12(a)}$ is admitted at the grid of V_6 , the anode load of which is the primary of the output transformer L_{20} , by-passed by a condenser C_{25} and connected direct to the H.T. positive input pin 5 of plug P_1 .

18. Before the potentiometer $R_{12(a)}$ there is an A.F. filter network composed of the condenser C_{10} , and an A.F. choke coil L_{20} . The A.F. filter network, which may be switched in or out of circuit by the switch S_2 , prevents the greater proportion of the frequencies below 300 c/s from reaching the volume control $R_{12(a)}$ and the output stage. The filter removes part of the noises due to the aircraft electrical and ignition systems. The A.F. filter characteristics are given in fig. 7 and the input/output characteristics in fig. 9.

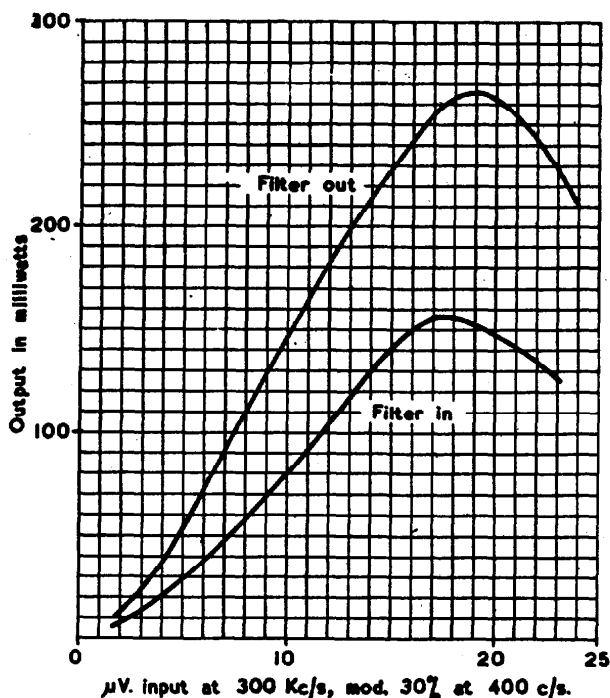

FIG. 9.—INPUT/OUTPUT CHARACTERISTICS

Manual volume control

19. Manual control of the gain of the R.F. and I.F. valves V_3 , V_4 , V_5 , and V_6 is effected by the application of varying degrees of grid bias to their respective grids by the potentiometer $R_{12(1)}$. When the master switch MS is in the OMNI position the grid of the output valve V_6 is joined through the section MS_{af} to the top end, that is, further from the H.T. negative, of the A.F. volume control $R_{12(2)}$ and the variable slider is out of circuit. The full A.F. voltage is therefore applied to the grid of V_6 . The automatic volume control (A.V.C.) system is inoperative.

20. With the switch at OMNI the circuits are:—

- (i) A fixed potentiometer, consisting of the resistors R_{10} , R_{11} , and R_{12} , is connected, through the switch contacts MS_{af} , to the slider of the manual R.F. gain control $R_{12(1)}$.
- (ii) The A.V.C. diodes of V_7 (strapped together) are connected, through the load resistor R_9 , to a point 3.6 volts negative along the resistors R_3 and R_4 , the rectified voltage across R_9 operating the tuning indicator V_{10} .
- (iii) On ranges 1 and 2 the switch FS_{wr} connects R_{44} (and R_{49} if fitted) across R_4 to reduce the minimum bias voltage and also the delay on the operating voltage of the indicator V_{10} .

21. The chassis is approximately 30 volts positive with respect to H.T. negative. The method by which this figure and that of the 3.6 volts negative, previously mentioned, are assessed may be understood from fig. 8. The effective resistance of the potentiometer networks across the supply, having regard to the switch positions, gives a basis for calculation. (Effective resistance should not be confused with the values given in the list of components.) The resistor R_1 has, at a minimum, $R_3 + R_4$ in parallel with it and these form a potential divider so that 26.4 volts are across R_3 and 3.6

volts across R_4 . The manual volume control $R_{8(1)}$ is connected across R_3 and any voltage between -3.6 and -30 can be applied to V_5 and V_4 for grid bias. This voltage is broken down by means of the potential divider R_{10} , R_{11} , and R_{12} for connection to V_6 and V_3 .

Automatic volume control

22. Automatic control of the gain of the valves V_3 , V_4 , V_5 , and V_6 , is effected by the strength of the received signals when the master switch MS is in the A.V.C. position. Manual control of the A.F. from the detector diode of V_8 to the output valve, that is, the triode of V_8 , is also provided from the potentiometer $R_{8(2)}$. The controls of $R_{8(1)}$ and $R_{8(2)}$ are ganged for operation and the panel knob is labelled VOLUME CONTROL. The position of the master switch MS determines which of the potentiometers is operative:—OMNI for $R_{8(1)}$, A.V.C. for $R_{8(2)}$. The received signal applied to the grid of the R.F. amplifier valve V_3 is amplified by the I.F. amplifier valves V_5 and V_6 . The amplified I.F. voltage appears across the primary winding of the third I.F. transformer L_{21} . This primary winding is tapped, and a proportion of the R.F. voltage is led to the strapped diodes of the double-diode-triode valve V_7 . Rectification takes place and the rectified current flows through a series R.F. choke L_{25} , and a resistance-capacitance filter and decoupling circuit composed of R_{88} and the condensers C_{103} and C_{103} .

23. At the A.V.C., BALANCE, and VISUAL positions, the switch section MS_{af} disconnects the slider of $R_{8(1)}$ and connects the fixed potentiometer R_{10} , R_{11} , and R_{12} across the A.V.C. diode load resistor R_9 . This diode has a delay of 3.6 volts due to the drop across R_4 in series with R_9 . On ranges 1 and 2 this delay is reduced to 2.4 volts by switching R_{64} (and R_{69} , if fitted) across R_4 . The rectified current flows through R_{10} , R_{11} , and R_{12} , with R_9 in parallel, back to the cathode *via* R_4 . The voltage developed across R_9 and the network R_{10} , R_{11} , and R_{12} , is divided to suit V_3 and V_6 . On BALANCE and VISUAL, C_{94} is shunted across R_9 to give a longer time constant and reduce the flicker of the tuning indicator V_{10} .

24. Approximately one-half the full value of the biasing voltage is applied to the R.F. amplifier valve V_3 through the line A.V.C.2, tapping the junction of R_{10} and R_{11} . The grid-return circuit includes the resistance-capacitance circuit of R_{45} and C_{40} to prevent back-coupling between V_3 , and V_4 , V_5 , and V_6 , and has a time-constant which is much longer than the lowest incoming signal frequency. The frequency-changer V_4 and the first I.F. amplifier V_5 receive full A.V.C. bias voltage from the top end of the resistor R_{10} through the line A.V.C.3 and decoupling combinations $R_{28}-C_{27}$ and $R_{28}-C_{28}$ respectively. The second I.F. valve V_6 receives approximately one-tenth of the bias voltage through the circuit $R_{28}-C_{30}$.

25. The A.V.C. is subjected to a voltage delay of approximately 13 volts, that is, it does not come into operation until the received carrier reaches the predetermined level of strength represented by 13 volts. This delay is partly accomplished by running the cathode of V_7 positive with respect to its diode anodes by means of resistors R_{14} and R_{15} which are connected between H.T. positive and earth. An additional resistor R_{16} is introduced for C.W. reception (i.e. when the switch S_4 is ON) to reduce this delay voltage. The full delay voltage is a composition of the voltage produced here and the standing bias on the R.F. valves (see para. 26). The voltage delay assists in giving an A.V.C. characteristic which, for a change in input signal of 80 db. results in a change in output of approximately 8 db.

26. None of the A.V.C. controlled valves is automatically biased by cathode resistors. To preserve a standing bias during no-signal periods, therefore, the resistance network of R_{12} , R_{11} , and R_{10} is returned to a point which is 3.6 volts negative with respect to the cathodes. On ranges 1 and 2 (H.F.) this standing bias is reduced by approximately 2.4 volts in order to preserve reasonably constant amplification over all ranges. This is done by introducing the resistors R_{64} , (and R_{69} , if fitted) into the circuit by means of switch section FS_{wr} .

Beat frequency oscillator

27. In addition to providing A.V.C. the valve V_7 also acts as a beat frequency oscillator, the triode section of the valve being used for this purpose. The oscillatory circuit is of the series-fed Colpitts type, and consists of a coil L_{23} and the condensers C_{14} and C_{15} . The frequency of this oscillator can be varied over a range of approximately 3 kc/s by means of a pre-set trimming condenser C_{13} . This condenser can be adjusted by inserting a screwdriver through a small port in the front panel. Automatic bias is developed across the grid leak resistor R_{19} . The grid coupling condenser is C_{17} . The oscillatory circuit is tuned to approximately half the I.F., that is, to 280 kc/s, and the second harmonic of this is used to heterodyne the I.F. signal. The use of the second harmonic prevents the oscillator from being locked by incoming I.F. signal. The output from the oscillator is coupled through the condenser C_{11} to the signal diode of the valve V_8 . The I.F. signal is also applied to this diode and the A.F. beat frequency voltage appears across the load resistor R_{21} .

Tuning indicator

28. Correct tuning of the receiver is indicated by a minimum angle of shadow in the tuning indicator valve V_{10} . This indicator gives a varying angle of shadow on a fluorescent "target" anode, the angle being dependent upon the voltage developed across the resistor R_9 , which is the A.V.C. diode load.

29. The tuning indicator valve operates as follows:—Connected to the triode anode is a "deflector" wire which protrudes into the path of the electron stream between the cathode and the target anode. In the absence of a signal the voltage across the resistor R_9 is small, and therefore the negative voltage applied to the grid of the indicator valve is small, resulting in a high current through the valve. This current produces a large voltage drop across R_{13} , in consequence of which the potential of the triode anode is considerably less than that of the target anode. The deflector wire therefore has a repelling action on the electrons approaching the target anode, and a V-shaped shadow is produced. When the receiver is correctly tuned, the voltage across R_9 reaches a maximum, the grid bias increases and the anode current falls. The reduced current results in a smaller voltage drop across R_{13} and the potential of the triode anode rises to a voltage comparable with that of the target anode. In this condition, therefore, the deflector wire has a much smaller influence on the electron stream, and the V-shaped shadow on the target anode narrows to a minimum.

COMMUNICATIONS CIRCUITS, OTHER VERSIONS

R.1155A, R.1155E, and R.1155M

30. These types differ from the R.1155 and R.1155D in the R.F. amplifier stage, where filters have been introduced to prevent interference from certain M.F. broadcasting stations having a carrier frequency near to the I.F. of the receiver (560 kc/s). Receivers bearing the suffix letter M are identical with the R.1155A except that a corrosive flux was used in error during production. Receivers type R.1155M are to be used at ground schools only.

31. The three filters are the grid rejector circuit, L_{23} and C_{113} , the anode rejector circuit, L_{22} and C_{114} , and the anode acceptor circuit L_{21} and C_{111} . In addition, an assembly consisting of the resistor R_{71} in parallel with condenser C_{112} is inserted to minimise the effects of the added capacitance introduced by the grid rejector circuit. The circuit changes will be seen by reference to fig. 3, where the modifications are shown as an inset on the full circuit diagram of the R.1155.

R.1155B and R.1155F

32. The circuit of these types incorporates the filter circuits of the R.1155A and, in addition, the six R.F. chokes annotated HFC_1 to HFC_6 in fig. 3A. These chokes are introduced to filter unwanted frequencies due to certain radar transmitters. As will be seen by reference to the circuit, fig. 3A, HFC_1 to HFC_4 are in series with the aerial leads; HFC_5 is in the common grid circuit of the L.F. switching valves V_1 and V_2 , and HFC_6 in the grid lead to the R.F. amplifier valve V_3 . A further slight alteration to the circuit is involved by the fitting of the condenser C_{115} in parallel with the resistor R_{72} between contact 3 of switch section FS_{21} and the primary of L_3 .

R.1155C

33. The R.1155C was a modified version of the R.1155A and was produced for use in Coastal Command aircraft engaged on certain duties necessitating D.F. facilities on Range 1. As this special requirement no longer exists the receivers have been declared obsolete, but some may still be found in service for normal communications purposes. The R.1155C required a special loop aerial in addition to that normally used, and the receiver embodied a new dummy loop circuit for ranges 1 and 2 in addition to the L_1 and C_{99} combinations used on the other ranges. These changes involved alterations also to the switching circuits. In view of the small number of receivers affected and the fact that they are obsolete, no circuit diagram is given.

R.1155L and R.1155N

34. The R.1155L and R.1155N are developments from the R.1155B and R.1155F to meet requirements for reception on the 1.5 to 3.0 Mc/s band. The frequency coverage therefore differs from that of the rest of the R.1155 series, range 5 (200 kc/s to 75 kc/s) having been omitted and range 2A (3.0 Mc/s to 1.5 Mc/s) inserted. Thus these types have a continuous frequency coverage from 18.5 Mc/s to 200 kc/s with the exception of the band between 600 kc/s and 500 kc/s. The changes have necessitated considerable alterations in the R.F. amplifier, frequency-changer, and R.F. oscillator stages, and a circuit diagram is given in fig. 4. Apart from the changes in these stages the circuit remains basically that of the R.1155B.

35. It will be seen that the coils L_6 , L_{11} , and L_{17} (range 5) have been removed from the circuit of the R.1155B. Range 3 and 4 coils have been repositioned in the circuit diagram and alterations

have been made in the wiring of the switch sections FS_{wt} , FS_{xt} , FS_{xt} , FS_{yt} , FS_{yt} , and FS_{xt} . Three new coils L_{40} , L_{41} , and L_{42} have been introduced for the new range 2A. Other components repositioned are the resistors R_{40} , R_{41} , R_{60} , and R_{61} , and the condensers C_{74} , C_{75} , C_{80} , and C_{91} . New resistors, R_{72} and R_{74} , and a condenser C_{116} have been added, and R_{59} and C_{78} have been removed.

THE DIRECTION-FINDING CIRCUITS

36. The change from the communications circuit to the direction-finding circuit is made by the master switch MS, of whose five positions the three labelled BALANCE, VISUAL, and ∞ (figure-of-eight) are for this purpose. Simplified diagrams of the D.F. circuits are given in figs. 10 to 13. The receiver may be used for direction finding on ranges 2, 3, 4, and 5. The D.F. ranges of the L and N versions are ranges 2, 3, and 4. On the R.1155C (now obsolete) D.F. was possible on ranges 1, 2, 3, 4, and 5. With a suitable loop aerial used in conjunction with the H.F. aerials the following facilities are available:—

- (i) Determination of bearing of a given transmitter, with sense discrimination by visual or aural means.
- (ii) Homing on to a transmitter by fixing the loop aerial in relation to the aircraft and maintaining course so that the two needles of the visual indicator type 1 intersect on a line marked centrally on the face of the instrument.

37. The loop aerial normally used is the type 3, which has a nominal inductance of 100 μ H, and self-capacitance when installed of 20 μ μ F. In order to effect a match between this aerial and the receiver a small pre-set condenser C_{104} is built into the loop lead terminating plug. When the total loop and lead capacitance is too small to enable tuning to be effected by C_{104} alone, the fixed condenser C_{106} may be inserted in parallel with C_{104} . The procedure to be adopted for matching is described in para. 72. When a loop aerial other than type 3 is employed a suitable impedance matching unit, such as the type 12, 13, or 15 should be used to enable the input tuned circuits to gang correctly with the other tuned circuits. These units are dealt with in Appendix 1.

General principles

38. Direction finding is accomplished either by visual or aural means. The aural method used follows the well-known practice of swinging the loop for a minimum, and then sensing by superimposing fixed aerial voltages on the loop voltages. (The theory of this system of direction finding is covered in Chapter XVI of A.P.1093.) The method used for direction-finding by visual means employs a principle known as the "switched heart". Before the circuit is dealt with in detail this principle should be understood; its features are briefly as follows.

39. A push-pull oscillator operating at either 30 c/s or 80 c/s is used to switch the fixed aerial in such a manner that its voltages are applied alternately in phase and in anti-phase with the instantaneous voltage due to the loop. The same oscillator simultaneously switches the rectified output from the detector stage alternately to the two pairs of moving coils which operate the indicator needles of a visual indicator. Thus one needle is moved to an extent proportional to the fixed aerial voltage plus the loop voltage, and movement of the other is proportional to the fixed aerial voltage minus the loop aerial voltage. Therefore, when the loop aerial is swung until the voltage induced in it is nil, both the needles will rise to the same extent. This will be when the loop is at right-angles to the bearing of the transmitter. This state of affairs is indicated by the point at which the crossed needles intersect falling on a vertical white line painted on the face of the instrument. For homing, the loop is set in relation to the aircraft—usually athwartships—(see para. 103 with regard to other settings) and the pilot swings the aircraft until the two needles cross on the vertical line, thereafter maintaining course by keeping the point of intersection of the needles on this line. Since the voltage actuating each needle is represented by a cardioid curve (see diagram C of fig. 14) it will be clear that any deviations from course will cause one needle to fall and the other to rise, as a result of which the point of intersection will move off the vertical line. The significance and use of such movements for sense determination is explained in paras. 52 and 99.

L.F. oscillator for D.F. switching

40. The triode portions of the triode-hexode valves V_1 and V_2 are connected as a push-pull oscillator. The frequency of this oscillator is determined by the constants of the tuned circuit consisting of the primary winding of the L.F. transformer L_{33} and the two fixed condensers C_{64} and C_{65} . When the switch S_1 is open the oscillatory frequency is 80 c/s. Closing the switch S_1 throws the condenser C_{66} into circuit and thereby lowers the frequency to 30 c/s. The higher frequency is used when D.F. is being carried out on a W.T. signal, and the lower frequency when R.T. signals are being used. The lower frequency causes negligible interference with R.T. intelligibility but is too low a switching frequency for W.T. signals.

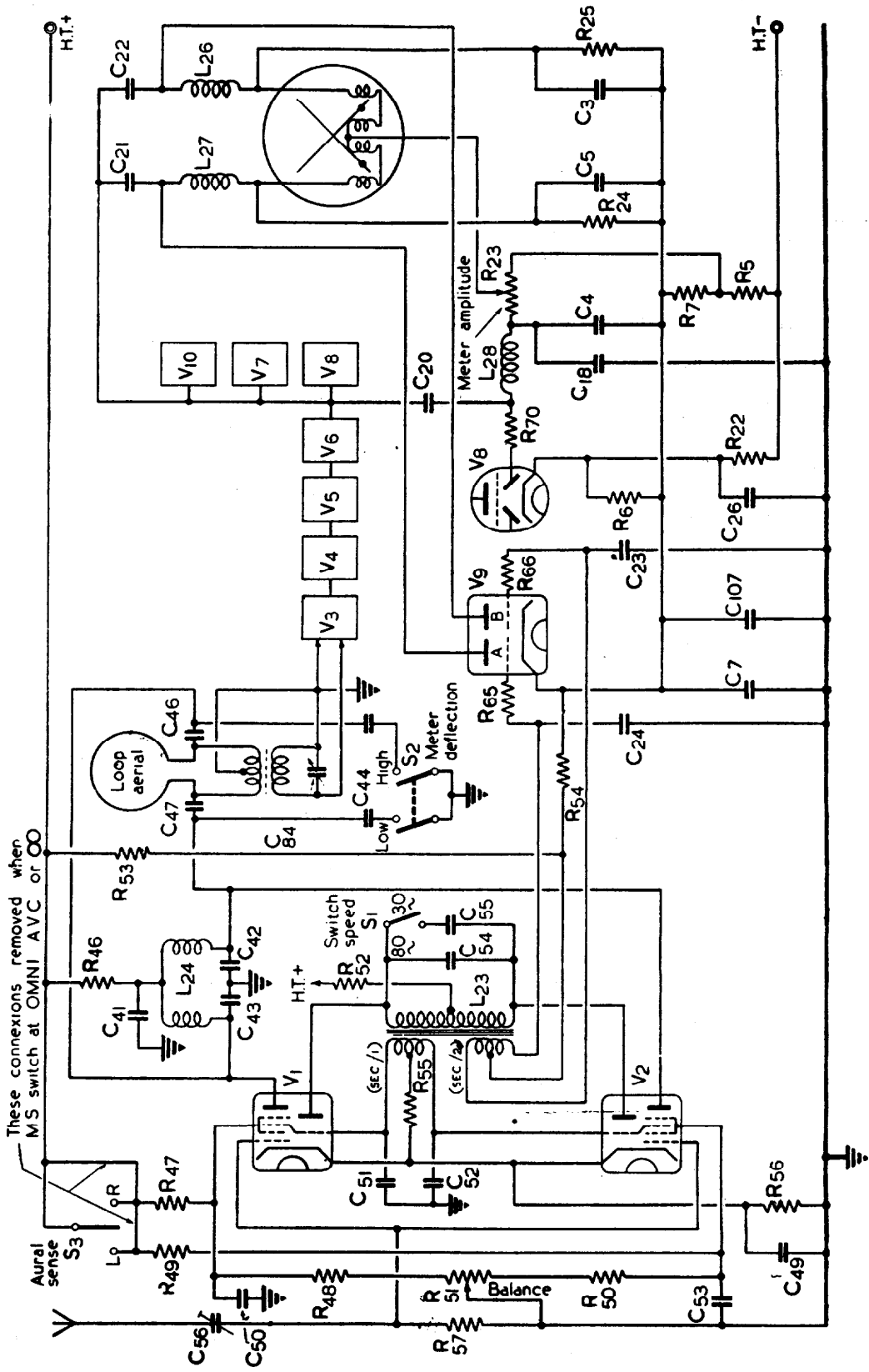

FIG. 10.—SIMPLIFIED VISUAL D.F. CIRCUIT

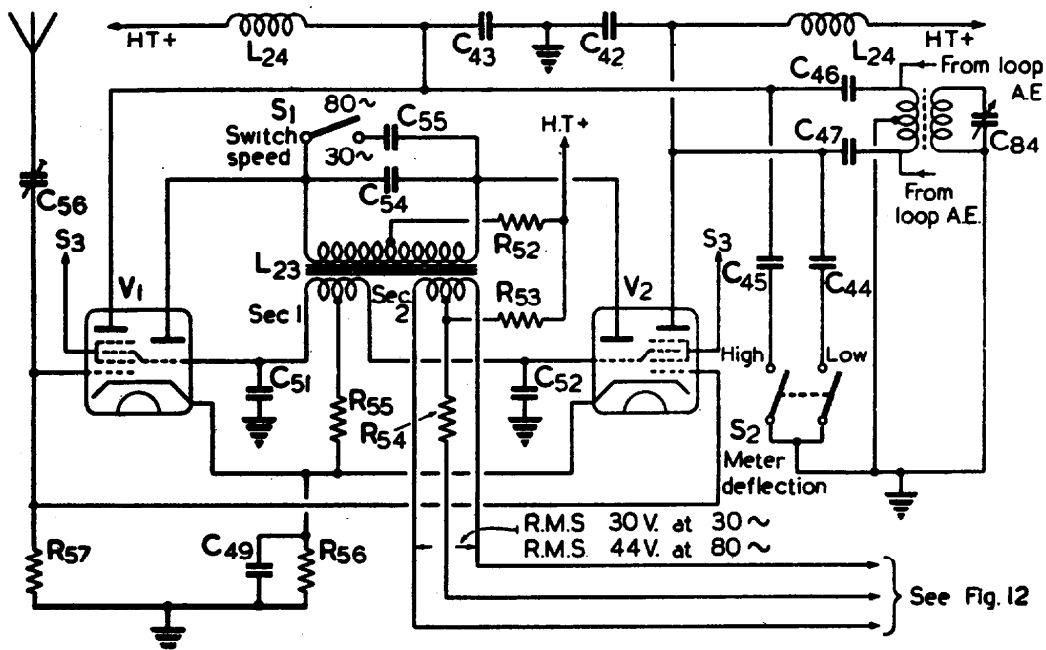

FIG. 11.—L.F. OSCILLATOR SWITCHING CIRCUIT

Aerial switching

41. The use of the centre-tapped secondary winding $sec 1$ of L_{23} has the effect of simultaneously applying equal, but anti-phase, voltages to the oscillator grids of V_1 and V_2 . During a positive half-cycle the grid is held only slightly positive due to grid current developing a biasing voltage across the resistor R_{55} . In the negative half-cycle the full secondary voltage is applied to the oscillator grids. Since these grids are connected to the injector grids (G_2) of the respective hexode portions, the effect is to bias the hexodes to cut-off during alternate half-cycles at the oscillator frequency. The fixed-aerial voltage is therefore applied through V_1 to C_{48} during one half-cycle, and during the next half-cycle, when the valve V_1 cuts off, the aerial voltage is applied through V_2 to C_{47} . As the two condensers C_{48} and C_{47} are at opposite ends of the loop aerial (and of the coil across it, which forms the primary of an R.F. transformer) the oscillator serves to switch the fixed aerial voltages at the oscillator frequency alternately into phase and anti-phase with the loop aerial input. The resultant voltages are applied to the grid of V_3 by inductive coupling to the grid circuit of the range in use.

42. The H.T. positive feed to the anodes of the triode sections is via a voltage dropping resistor R_{53} and the centre tap of the primary winding of L_{23} . The hexode anodes are fed through the R.F. choke assembly L_{24} and the dropping resistor R_{44} . The associated by-pass condensers are C_{41} , C_{42} , and C_{43} . A suitable screen voltage is provided by the two potentiometers R_{47} , R_{48} , and R_{51} , or R_{49} , R_{50} , and R_{51} , the by-pass condensers being C_{50} and C_{53} . The cathode bias is provided by the resistor R_{56} by-passed by C_{49} . R_{57} provides a grid return for the hexodes.

Visual indicator switching

43. The basic principles of operation of the visual indicator have been explained in paras. 38 and 39, and the switching circuit employed to operate the visual indicator, type 1, will now be dealt with in detail. Simplified circuits are given in figs. 12 and 13.

44. The amplified signal voltages are applied to the anodes of the double-triode valve V_3 . It is convenient to regard the two sections A and B of V_3 as diodes which are switched into and out of operation by the grids G_1 and G_2 . The grids are connected to a secondary winding $sec 2$ of the L.F. transformer L_{23} and, by a similar arrangement to that used in the oscillator stage, equal but anti-phase voltages are applied to the two grids of V_3 in synchronism with the aerial switching. The voltage applied to the grids of V_3 is approximately 30 volts (R.M.S.) at 30 c/s or 44 volts at 80 c/s. The resistors R_{53} and R_{54} constitute a potentiometer connected between H.T. positive and the cathode of V_3 . The grid returns of V_3 are connected to the junction of these two resistors and consequently the grids are at a potential positive with respect to the cathode, reducing the valve impedance and increasing sensitivity.

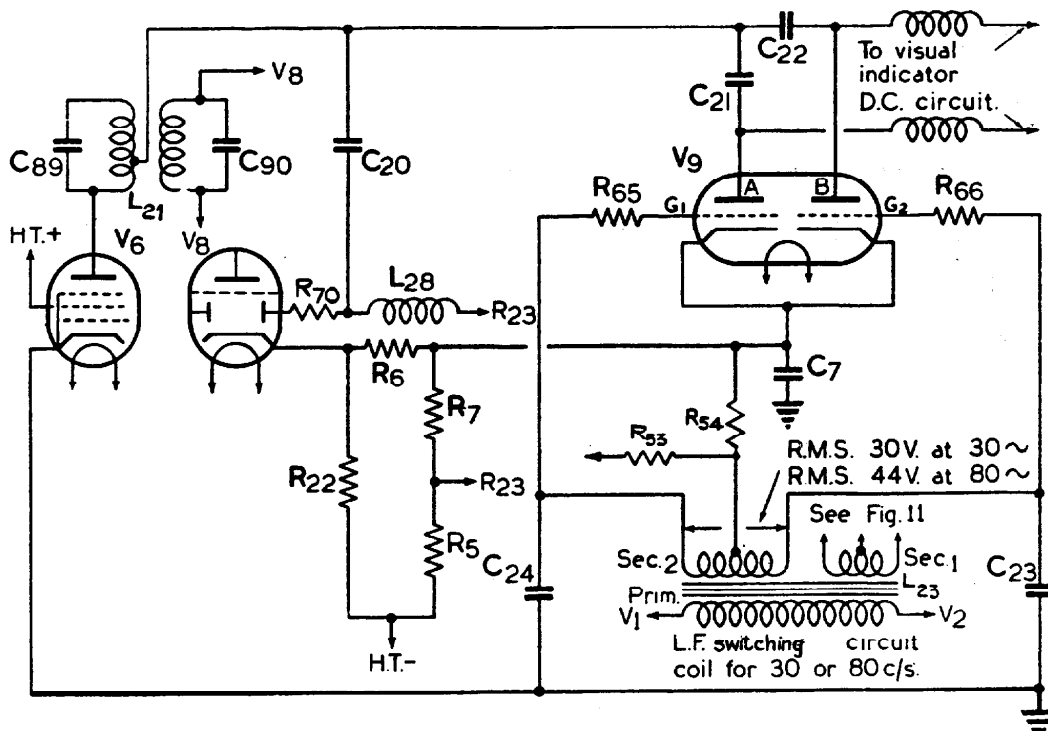

FIG. 12.—VISUAL INDICATOR SWITCHING CIRCUIT

45. It will be seen from fig. 13 that the diodes A and B rectify the signal impulses, but owing to the switching voltage applied to the grids of V_9 from the L.F. transformer L_{23} they are alternately conducting and non-conducting according to the condition of the grid. Since this switching is synchronised with the aerial switching the output of one diode will be proportional to the fixed aerial voltage plus the loop voltage, and the output of the other diode will be proportional to the fixed aerial voltage minus the loop voltage as stated in para. 39. The pulsating D.C. output produced through diode A will tend to charge the fixed condenser C_5 which is across the anode load resistor R_{24} and will at the same time flow through the two left-hand coils of the visual indicator and the variable resistor R_{23} . The effect will be to actuate the needle which points to the right, causing it to rise. Collapse of the needle during the alternate (negative) half-cycle of the switching voltage is prevented by the charge on C_5 , which tends to discharge through the circuit VPZW. In a similar manner the needle which points to the left is operated by diode B and its associated load R_{25} and condenser C_3 , with the common resistor R_{23} . When the charges on the condensers C_5 and C_3 are equal the needles will rise by equal amounts and will therefore intersect on the central line marked on the instrument, but when the charges are unequal the needles will rise to different heights giving an intersection to left or right of the centre line according to which section is passing the greater current. In addition, when the charges on C_5 and C_3 are unequal there is a tendency for current to flow between V and X via P (see fig. 13), a circumstance which assists the differential action of the needles.

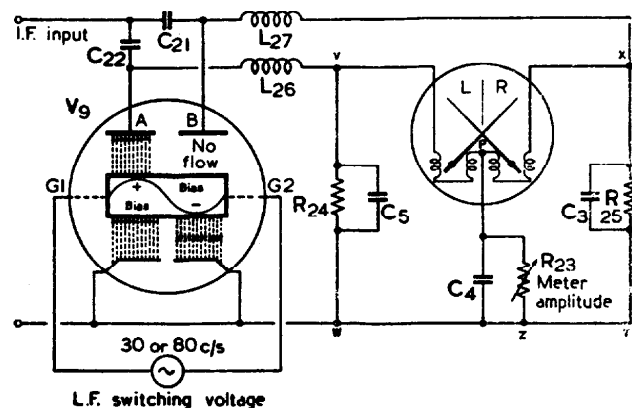
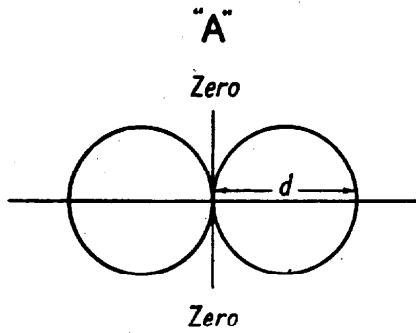

FIG. 13.—SIMPLIFIED VISUAL INDICATOR SWITCHING CIRCUIT

Meter amplitude

46. The sharpness of a bearing is determined by the relative amplitudes of the fixed and loop aerial voltages. When these are equal the sharp minimum shown in curve C of fig. 14 is obtained.



Loop aerial alone
(also condition of aural "nulls")

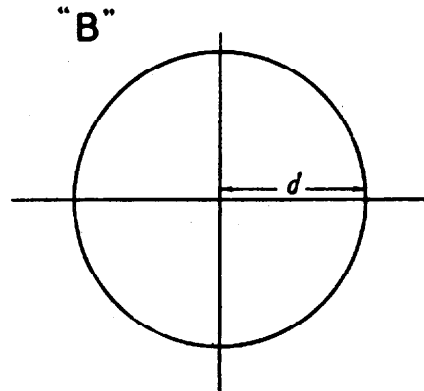

Vertical aerial alone

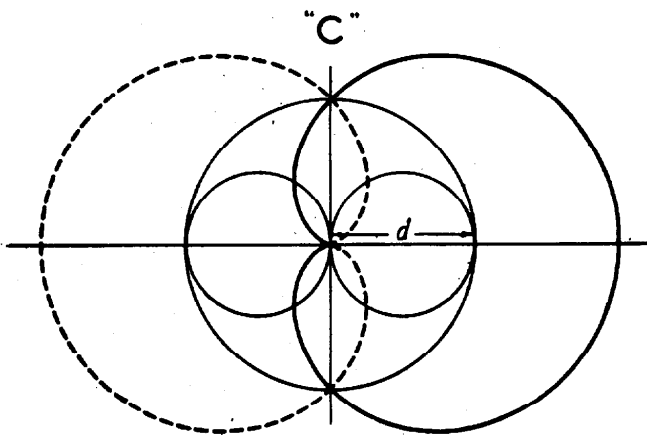

Vertical superimposed upon loop in phase and anti-phase. Amplitude of vertical and loop voltages equal. This also represents the momentary condition for aural sense discrimination when S_3 is switched R. or L.

Note - These polar graphs illustrate the effect of vertical aerial voltage amplitude upon the visual indicator response.

$\angle \theta$ is measure of $\frac{\text{Signal}}{\text{Off-set}}$ ratio.

(Off-set = degrees rotation of loop aerial)

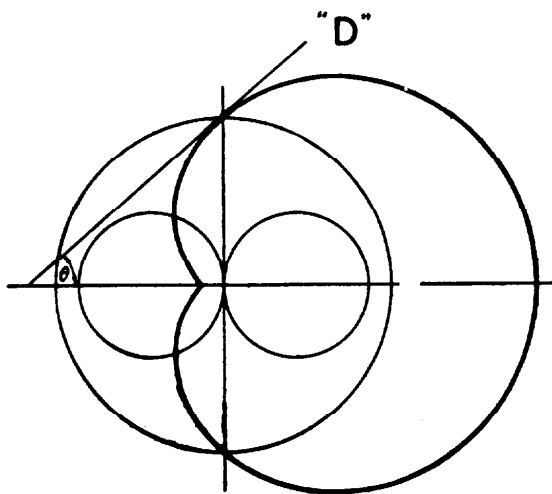

Vertical amplitude > loop amplitude.
(Low sensitivity switch S_2 off)

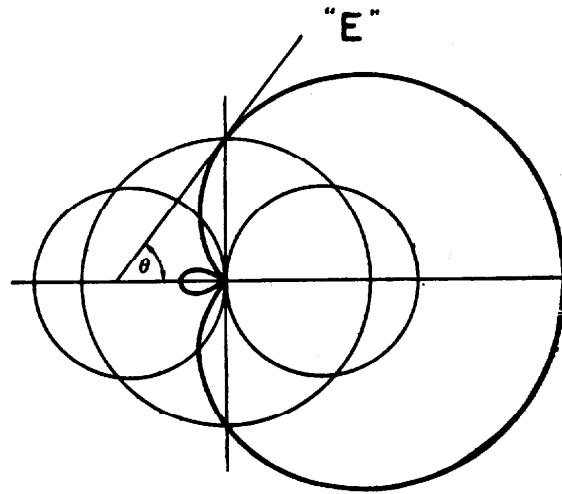

Vertical amplitude < loop amplitude
(High sensitivity switch S_2 on)

FIG. 14.—POLAR DIAGRAMS

When the fixed aerial voltage is greater than the loop aerial voltage the minimum is less sharp, as will be seen by the flattening of the cardioid curve D of fig. 14. When the loop voltage is the greater an additional lobe is introduced into the polar diagram, and two minima are obtainable (curve E of fig. 14). The two condensers C_{42} and C_{43} are provided to reduce the amplitude of the fixed aerial voltages to the correct value for a sharp minimum.

47. When using the visual indicator for homing this sharp minimum is a disadvantage, as a very small deviation off course causes a considerable movement of the needles, with consequent strain upon the pilot in maintaining course. To eliminate this difficulty a meter sensitivity switch is provided. This switch has two positions HIGH and LOW, indicating high and low sensitivity respectively. In the LOW position the switch introduces the further condensers C_{44} and C_{45} in parallel with C_{42} and C_{43} respectively, reducing the fixed aerial voltage relative to the loop voltage. This results in a less sharp minimum and homing is therefore simplified.

The diode limiter valve

48. It has already been explained that the pulsating D.C. output from V_6 is fed through the R.F. chokes L_{26} and L_{27} to the actuating coils of the visual indicator. In order to prevent the needles rising due to noise output in the absence of a signal, a delay bias is provided between cathode and anode. One diode of the double-diode-triode valve V_9 is fed through a condenser C_{20} from a tapping on the primary winding of the I.F. transformer L_{21} . The rectified output from V_9 flows via a swamp resistor R_{70} , and the R.F. choke L_{28} to the meter amplitude control, which is the variable resistor R_{23} . The cathode of V_9 is biased by the resistor R_{22} . Any current injected at R_{23} tends to drive both needles downwards without interfering with the differential action of the circuit. The action of the normal A.V.C. alone is insufficient to keep the intersection point of the needles on the scale for the possible range of signal variation.

49. The limiter delay voltage is supplied across the resistors R_6 and R_7 and is about 4 volts. It does not come into action until the peak voltage applied to the common point of C_{20} , C_{21} , and C_{22} exceeds the delay voltage. This limiter device is effective for changes up to 80 db and, given a correct setting of R_{23} , the point of intersection will not move beyond the limits of the scale.

Visual indicator balancing circuit

50. Accuracy of indication depends on the balancing of the two input switching valves V_1 and V_2 and their associated circuits. Balance is achieved by the potentiometer R_{51} . When the master switch MS is in the BALANCE position the loop aerial is disconnected and earthed by MS_{ef} and a dummy loop consisting of a coil L_1 and condenser C_{99} is connected in its place (see fig. 3). As the dummy loop does not pick up signals any deflection of the point of intersection of the visual indicator needles is due to lack of symmetry in the circuit. To correct this the potentiometer R_{51} is adjusted until the intersection point coincides with the central indicating line of the instrument.

51. After renewal of one of the valves V_1 or V_2 it may be found to be impossible in some receivers to effect balance within the limits of the balance control knob. In such a case it will be necessary to replace one of the valves with another whose characteristics are such that they will permit a balance. The unmatched valve displaced is not to be discarded but is to be matched with another V.R.99A for future use.

Visual sense determination

52. The direction of movement of the visual indicator needles reflects the angle of the plane of the loop aerial relative to the path of the incident wave. Orientation of the loop is such that, having obtained a bearing by turning it so that the needles cross on the white line, a reduction in loop reading by a few degrees will cause the needles to fall to the *right* if the sense is *correct*. If the needles fall to the left when the loop reading is reduced the bearing is 180° out, i.e. it is a reciprocal. For homing the sense test is to swing off course to the left. If the needles move to the *right* the sense is *correct*.

Aural D.F.

53. For aural D.F. the fixed aerial is disconnected by the master switch MS_{bf} and the loop aerial gives a figure-of-eight polar diagram as shown in curve A of fig. 14. The switch section MS_{cf} breaks the H.T. supply to the L.F. oscillator, rendering the switching circuits inoperative. The volume control is switched, changed from automatic to manual by MS_{af} and MS_{cf} . To overcome the 180° ambiguity which results from the use of a loop aerial alone, the three-position switch S_3 is operated. This switch applies H.T. to the screens of one or other of the hexode portions of V_1 or V_2 thus coupling the fixed aerial through to the loop circuit, and producing a cardioid polar diagram. Sense determination by aural means is described in paras. 104 to 106.

CONSTRUCTIONAL DETAILS

54. The control panel of a receiver, type R.1155N is shown in fig. 1. Illustrations of the R.1155 are given in fig. 15, which is a view of the upper deck of the chassis, and fig. 16 which shows the chassis underside view. The diagram of fig. 17 gives the location of components. To facilitate search this diagram is gridded and a reference table is provided. The additional filtering components incorporated in later models may be seen from figs. 18 and 19, which are illustrations of a R.1155B. The receiver is removed from its case by loosening the four screws at the corners and by pulling the handles. All cable connections to the receiver are terminated in plugs and sockets which are non-reversible and non-interchangeable. Cables are, wherever possible, metal braided, the braiding being earthed to reduce interference from external sources. Details of the cables and connections are given in Table A overleaf. The receiver case, chassis, and panel are of metal, and are earthed to the main bonding system of the aircraft.

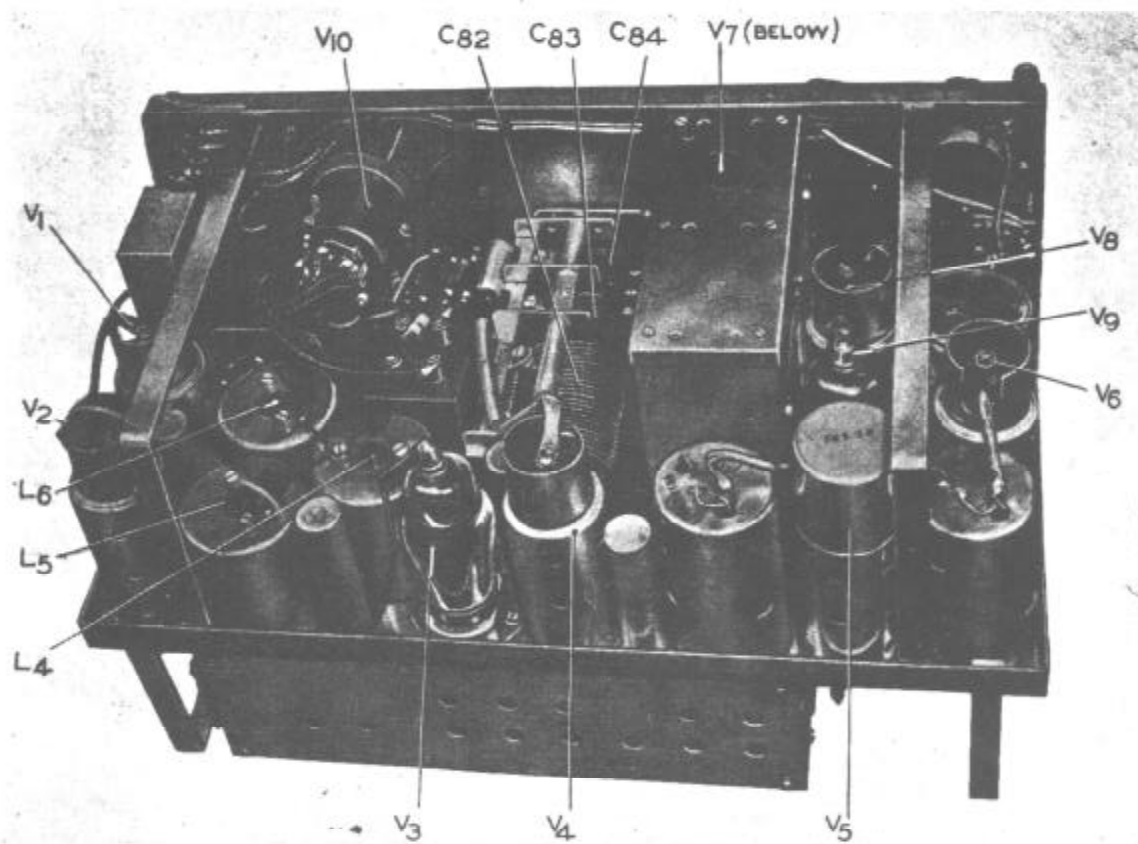

FIG. 15.—R.1155 CHASSIS, UPPER DECK

Front panel controls

55. Referring to fig. 1, a metal strip and metal posts hold the cable connector plug and sockets securely to the receiver. The calibrated tuning dial, which differs as to type in certain models, shows the frequency to which the receiver is tuned by a pointer. The tuning control has two speeds, and is coupled to a three-gang condenser comprising C_{82} , C_{83} , and C_{84} . In some models the drive used is the Drive, slow motion, Type 13, in which instance the outer knob gives a direct drive and the inner knob a 100:1 ratio drive for fine tuning. Other models have a Type 35 drive with 4.5:1 (inner knob) and 80:1 (outer knob) ratios. The exact point of correct tuning is shown by minimum shadow in the tuning indicator, V_{10} , located at the top right-hand side of the tuning scale.

56. The tuning dial has five scales, one for each of the five ranges, each scale being calibrated in Mc/s or kc/s. Originally, the tuning scales of the R.1155 were coloured over those portions which corresponded to the blue, red, and yellow colouring of the controls of the T.1154.

As a result of the introduction of new ranges in later models of both the receiver and the transmitter it may be found that this correspondence of colour does not exist between the receiver and transmitter of some installations. In some models of the receiver all the scales are printed in black.

57. The master switch MS has five positions labelled \odot ("OMNI"), A.V.C., BALANCE, VISUAL, and ∞ ("FIGURE-OF-EIGHT"). Details of these positions are given in paras. 9 and 91.

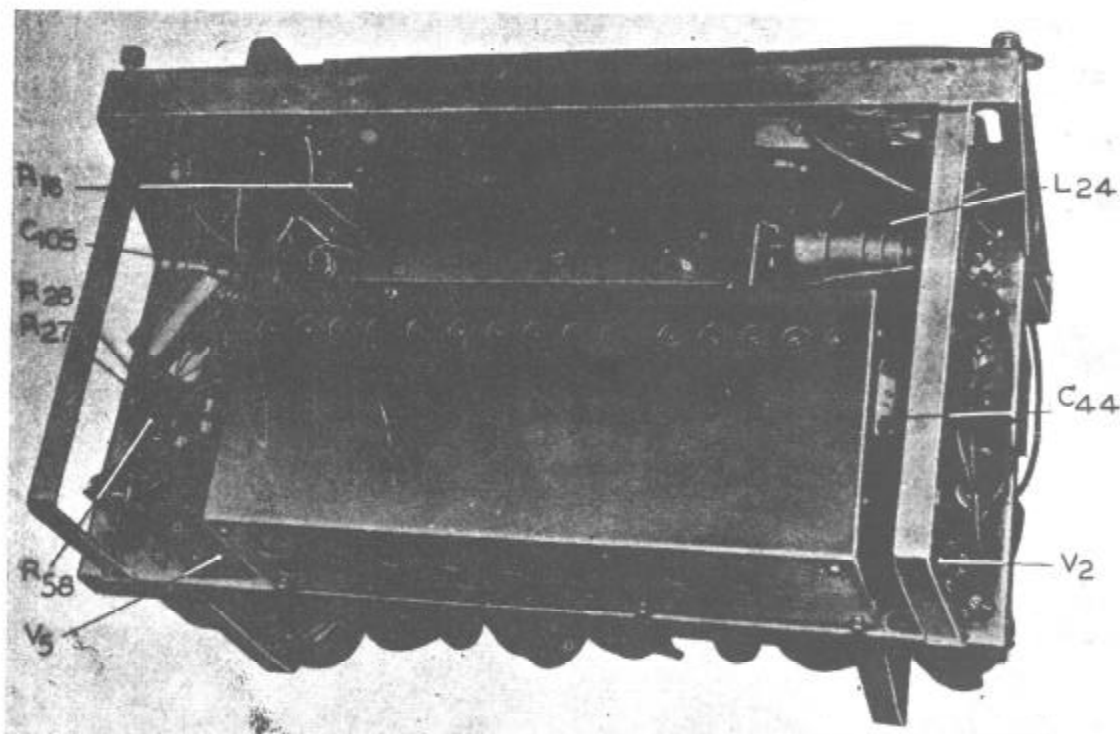

FIG. 16.—R.1155 CHASSIS, UNDERSIDE

58. The frequency range switch FS is at the lower left-hand side of the tuning scale and selects the five frequency ranges. Its five positions are engraved with the numerical band coverage. It is composed of one switch type 368 for oscillator wafer, one switch type 369 for anode wafer, one switch type 370 for aerial wafer, and one switch type 371 for the loop aerial wafer.

59. The remaining front panel controls include the L.F. filter switch S_5 , the meter amplitude control R_{23} , the heterodyne switch S_4 , the meter sensitivity switch S_2 , and the meter frequency switch S_1 . The aural sense switch S_3 has three positions and is spring-loaded to cause it to revert to the centre position when not held to the left or to the right.

60. Screwdriver adjustment is provided for the condensers C_{13} and C_{36} . The condenser C_{13} varies the B.F.O. frequency and is adjustable between capacitance limits of from $5 \mu\mu\text{F}$ to $60 \mu\mu\text{F}$. The fixed aerial input to the switching valves V_1 and V_2 and thence to the loop aerial is adjusted when the receiver is installed, by means of C_{36} which is variable between $8 \mu\mu\text{F}$ and $115 \mu\mu\text{F}$.

Chassis layout

61. The panel is attached to a metal tray, braced top and bottom by strips returned to the panel upper and lower edges. The strips provide an equalising fit into the receiver container. The upper deck view in fig. 15 shows the chassis with valves in position. For the purposes of this illustration the screening container of the valve V_3 has been removed. The disposition of the components can be seen in the location diagram of fig. 17, which is drawn from the R.1155 chassis. This diagram, when studied in conjunction with figs. 15, 16, 18, and 19 and the relevant portions of the text, should serve also for the later models of the receiver.

TABLE A
PLUGS, SOCKET, AND CONNECTORS FOR R.1155

Single receiver with visual indicator, type 1				
Points	SOCKET P ₂ FROM LOOP AERIAL	PLUG P ₂ TO VISUAL INDICATOR (when only one fitted)	PLUG P ₂ TO VISUAL INDICATOR (when two are fitted)	PLUG P ₁ FROM TRANSMITTER
1	—	To V.I. terminal A (Green)	To V.I. terminal A (Green)	F.Ae. (H.F. Ranges)
2	—	To V.I. terminal D (Red)	To V.I. terminal D (Red)	T.Ae. (H.F. Ranges)
3	—	To V.I. terminals B, C (Blue)	To V.I. terminal F (Blue)	L.T.+
4	—	To V.I. screening earth	To V.I. screening earth	L.T.— and screen earth
5	—	—	—	H.T.+ through interlock
6	—	—	—	Telephone+
7	—	—	—	H.T.+ 220-v.
8	—	—	TERMINAL CONNECTIONS FOR ADDITIONAL CONNECTOR	
13	Earth	—	First V.I.	Second V.I.
14	Earth	—	B	A
15	MSe _f contact 5 and loop	—	C	D
16	MSe _f contact 11 and loop	—	F	BC
	CONNECTOR Plug, type 209 Duradio No. 20 Socket, type 63 or Cable end eye (to matching unit)	CONNECTOR Socket, type 137 Trimet 4 Cable end eye	ADDITIONAL CONNECTOR (Between visual indicators) Cable end eye Trimet 4 Cable end eye	
				CONNECTOR Socket, type 137 Octocorem _t No. 2 Plug, type 210

Two receivers with two indicators
W.T. operator's receiver

SOCKET P ₂	PLUG P ₂	PLUG P ₁
Dummy socket block inserted		As above
		CONNECTOR As above

Navigator's receiver

SOCKET P ₂	PLUG P ₂	PLUG P ₁
Points and connector detail as for single receiver (above)		CONNECTOR Socket, type 299 Dumet 4 and 7 (to power unit) Plug, type 358 Ducel 4 (to telephones) Terminal block B (2-way) Unicel 4 (to aerial) Cable end eye

LOCATION OF COMPONENTS (GRID REFERENCES)

This table should be read in conjunction with fig. 17

CONDENSERS

Component	Grid Ref.	Component	Grid Ref.	Component	Grid Ref.	Component	Grid Ref.
C ₁	Cb	C ₂₉	Dc	C ₅₇	Ah	C ₈₅	Dc
C ₂	Db	C ₃₀	Dc	C ₅₈	Ah	C ₈₆	Dc
C ₃	Ab, Dc	C ₃₁	Dc	C ₅₉	Ag	C ₈₇	Dd
C ₄	Ab, Dc	C ₃₂	Db	C ₆₀	Ag	C ₈₈	Dd
C ₅	Ab, Dc	C ₃₃	Db	C ₆₁	Ag, Ah	C ₈₉	Cd
C ₆	Ce	C ₃₄	Be	C ₆₂	Ag	C ₉₀	Cd
C ₇	Cf	C ₃₅	Bf	C ₆₃	Af	C ₉₁	Ae
C ₈	Cd	C ₃₆	Db	C ₆₄	Af	C ₉₂	Cb
C ₉	Cd	C ₃₇	Ag	C ₆₅	Af, Ag	C ₉₃	Ca, Dh
C ₁₀	Cd	C ₃₈	Ag, Bg	C ₆₆	Ag	C ₉₄	Cb
C ₁₁	Ce	C ₃₉	Bf, Db	C ₆₇	Ag	C ₉₅	Da
C ₁₂	Bc	C ₄₀	Ag	C ₆₈	Af	C ₉₆	Cd
C ₁₃	Ac, Cc	C ₄₁	Da	C ₆₉	Ae	C ₉₇	Dc
C ₁₄	Bc	C ₄₂	Cg	C ₇₀	Ae, Af	C ₉₈	Dd
C ₁₅	Ac	C ₄₃	Cg	C ₇₁	Af	C ₉₉	Ah
C ₁₆	Cc	C ₄₄	Cg	C ₇₂	Af	C ₁₀₀	Ca
C ₁₇	Ac	C ₄₅	Dg, Dh	C ₇₃	Ae, Af	C ₁₀₁	Cd
C ₁₈	Ab	C ₄₆	Dg	C ₇₄	Ae, Af	C ₁₀₂	Ca
C ₁₉	De	C ₄₇	Cg	C ₇₅	Ae, Af	C ₁₀₃	Ce
C ₂₀	Ab	C ₄₈	Ca	C ₇₆	Bc, Bf, Af	C ₁₀₄	Plug type 209
C ₂₁	Ab	C ₄₉	Da	C ₇₇	Be, Bf	C ₁₀₅	De
C ₂₂	Ab	C ₅₀	Da	C ₇₈	Af	C ₁₀₆	Plug type 209
C ₂₃	Ce, Cf	C ₅₁	Da	C ₇₉	Af	C ₁₀₇	Ab
C ₂₄	Ce, Cf	C ₅₂	Da	C ₈₀	Af	C ₁₀₈	Ce
C ₂₅	De, Df	C ₅₃	Da	C ₈₁	Bf	C ₁₀₉	Ab
C ₂₆	Cd, Ce	C ₅₄	Cb	C ₈₂	Db, Ch	C ₁₁₀	Ag, Ah
C ₂₇	Cd, Ce	C ₅₅	Ca	C ₈₃	Cb		
C ₂₈	Cd, Ce	C ₅₆	Ca	C ₈₄	Cb		

RESISTANCES

R ₁	Cb	R ₁₉	Ac	R ₂₇	Bf	R ₃₅	Cb
R ₂	Ca	R ₂₀	Ce, De	R ₂₈	Bf	R ₃₆	Dg
R ₃	Ce, De	R ₂₁	Ce	R ₂₉	Bf	R ₃₇	Ca
R ₄	Ce	R ₂₂	De	R ₃₀	Ae	R ₃₈	Df
R ₅	Cd	R ₂₃	Cc	R ₃₁	Ae	R ₃₉	Af, Ag
R ₆	Cf, Df	R ₂₄	Ac, Bc	R ₃₂	Ae	R ₄₀	Af
R ₇	Cd	R ₂₅	Bc	R ₃₃	Bf	R ₄₁	Af
R ₈	Cc	R ₂₆	De	R ₃₄	Bg	R ₄₂	Dh
R ₉	Ce	R ₂₇	Df	R ₃₅	Bf	R ₄₃	Dh
R ₁₀	Bf	R ₂₈	De	R ₃₆	Ch	R ₄₄	Ce
R ₁₁	Df	R ₂₉	Dd	R ₃₇	Ca	R ₄₅	Cf, Df
R ₁₂	Df	R ₃₀	Dd	R ₃₈	Ca	R ₄₆	Cc
R ₁₃	Ca	R ₃₁	Df	R ₃₉	Ca	R ₄₇	Cd
R ₁₄	Bc	R ₃₂	Df	R ₄₀	Ca	R ₄₈	Ce
R ₁₅	Ce	R ₃₃	Dc	R ₄₁	Cd	R ₄₉	Bh (if used)
R ₁₆	Ce	R ₃₄	Dc	R ₄₂	Cb		Cf
R ₁₇	Bc	R ₃₅	Ae	R ₄₃	Cb		
R ₁₈	Ac, Bc	R ₃₆	Bf	R ₄₄	Ca		

COILS AND CHOKES

L ₁	Ah	L ₉	Af	L ₁₇	Af	L ₂₅	Ce
L ₂	Ag	L ₁₀	Af	L ₁₈	Af	L ₂₆	Ab
L ₃	Ag	L ₁₁	Af, Ag	L ₁₉	Dc, Be	L ₂₇	Ab, Cc
L ₄	Db	L ₁₂	Ag	L ₂₀	Dd	L ₂₈	Bb
L ₅	Da	L ₁₃	Af	L ₂₁	De	L ₂₉	Cd
L ₆	Ca	L ₁₄	Af	L ₂₂	Ac	L ₃₀	Ce
L ₇	Ag	L ₁₅	Ae	L ₂₃	Ch		
L ₈	Af, Ag	L ₁₆	Ae	L ₂₄	Ch		

VALVES

V ₁	Ca, Dh	V ₄	Db, Bf	V ₆	Dd, De,	V ₉	Cc
V ₂	Da, Dg	V ₅	Dc, Df	V ₇	Df	V ₁₀	Dc, Df
V ₃	Db, Bf, Bg				Bc, Cc		Ca

SWITCHES

S ₁	Ba	S ₃	Ba	S ₅	Bc	F.S.	Af to Ah,
S ₂	Ba	S ₄	Ce	S ₆	Ca		Cf

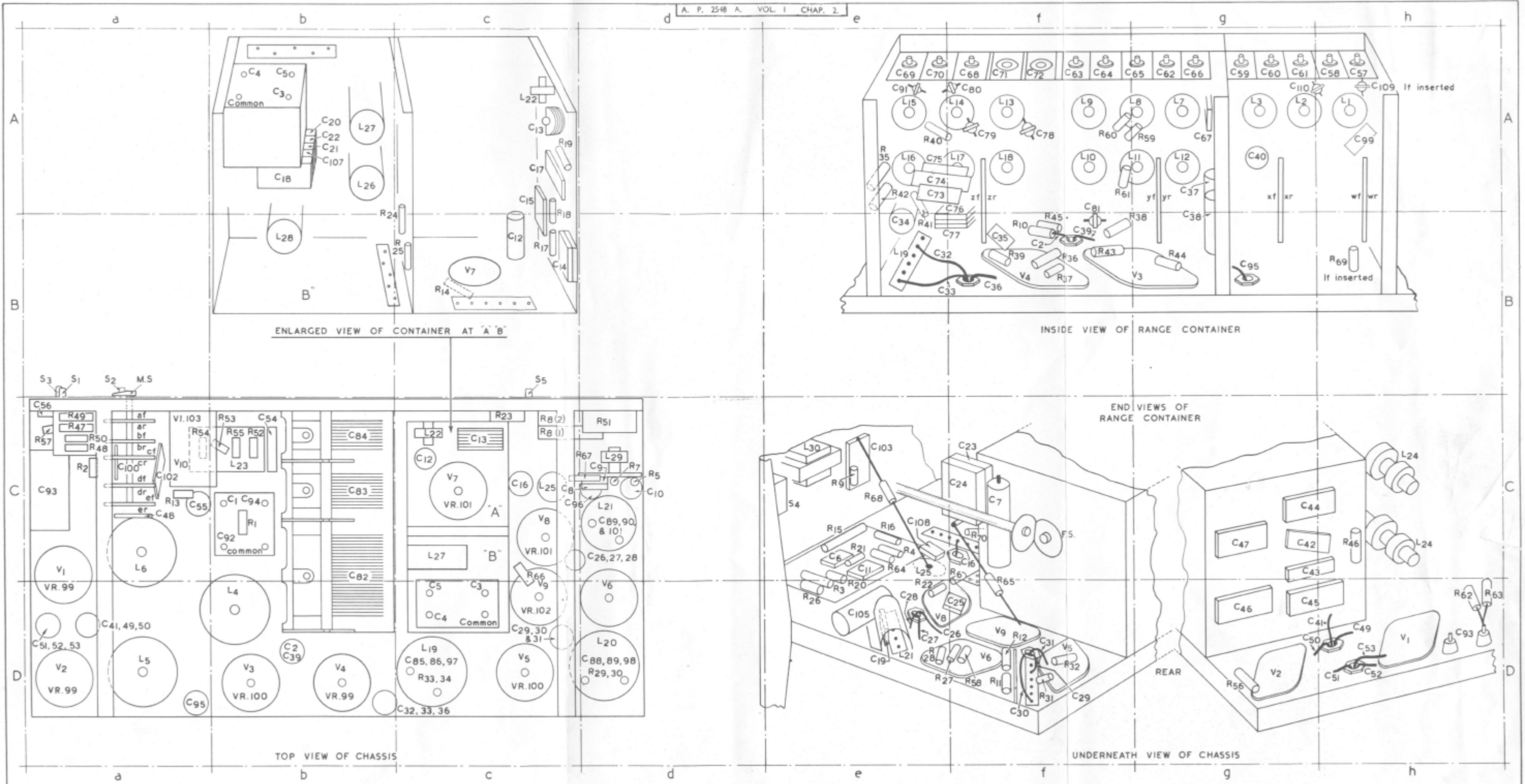

FIG. 17

COMPONENTS LOCATION DIAGRAM

FIG. 17

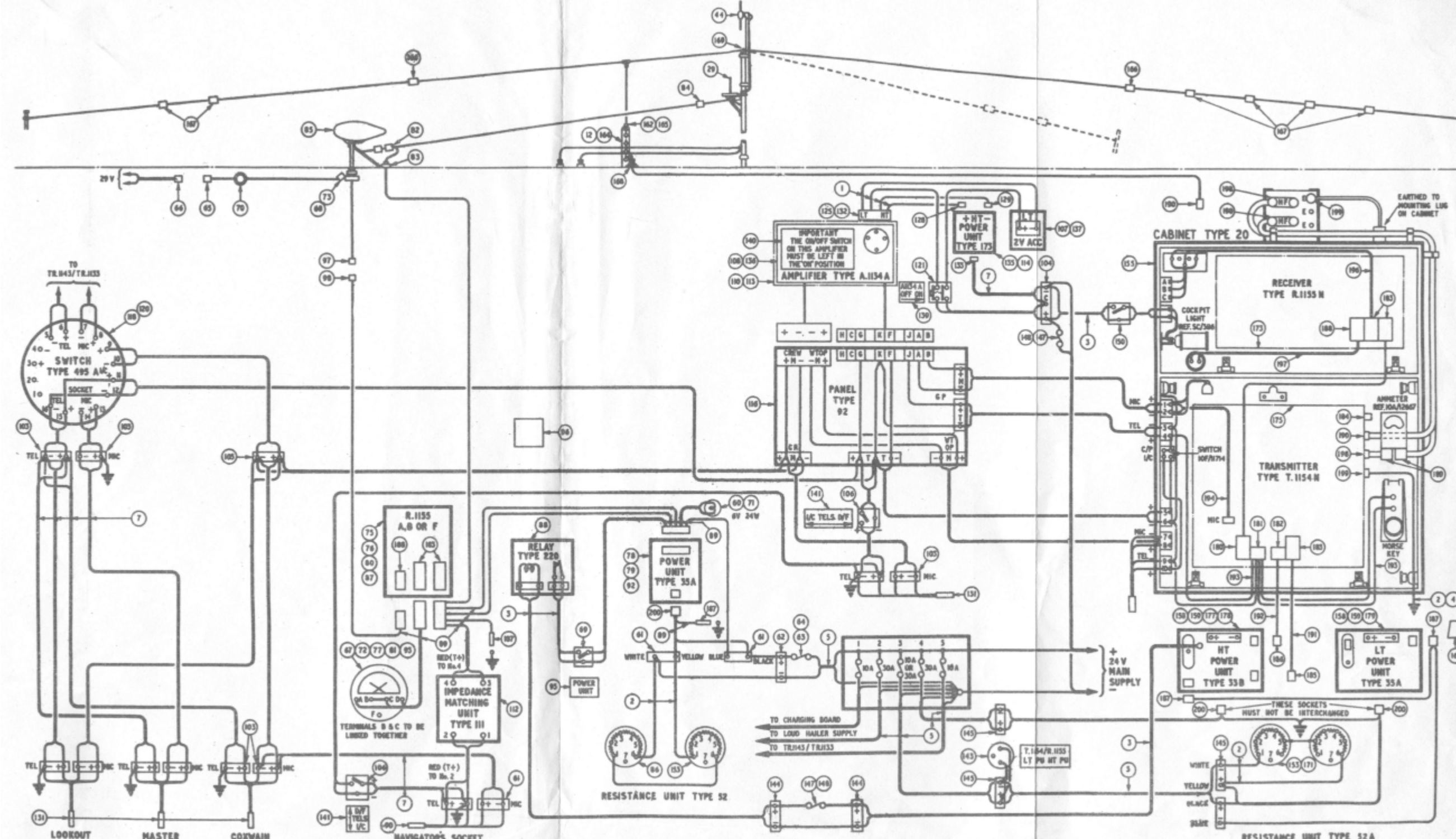

FIG. 1

T. 1154N/R.1155N - INSTALLATION IN MARINE CRAFT

FIG. 1

the W/OP. should check the D/F signals his switch should also be at D/F.

Aerial system

15. The aerial used depends on the type of craft in which the transmitter is installed. A typical one consists of about 27 ft. of stainless steel aerial wire supported at the masthead by an insulator Type 16 (Stores Ref. 10B/

8093) and at each end by insulators Type 17 (Stores Ref. 10B/8097). The supporting wires between the insulators Type 17 and the jack stays are broken into lengths not exceeding 6 ft. by further insulators of the same type. The aerial lead, of Unispark 7, is joined to a point about 10 ft. from one end of the aerial. This installation is not standard and is quoted only as an example of what may be met with in practice.

R E S T R I C T E D

Chapter 6

INSTALLATION IN MARINE CRAFT

LIST OF CONTENTS

	Para.		Para.
Introduction	1	Navigator's receiver	12
Intercomm. facilities	8	Aerial system	15

LIST OF ILLUSTRATIONS

	Fig.
T.1154N/R.1155N.—Installation in marine craft	1

Introduction

1. A diagram of the T.1154N/R.1155N installation in a marine craft is given in fig. 1. A key to the number references on this diagram will be found in Appendix 1. Provision is made in the receiver R.1155N for loop aerial D/F on ranges 2, 3 and 4 and bearings can be taken by either visual or aural means. Normally, D/F bearings are taken by the navigator using a separate receiver R.1155A, B or F, although provision is made for connecting the loop aerial to the R.1155N. Transmitter and receiver obtain their supplies from the 24-volt DC system of the marine craft through two rotary transformer power units known as the LT power unit and the HT power unit. An additional LT power unit is installed to supply the separate receiver R.1155A, B or F used by the navigator mainly for D/F bearings.

2. The wireless operator's transmitter and receiver are housed in a cabinet Type 20 (Stores Ref. 10A/15227). Both instruments are base-mounted, the transmitter on mountings Type 211 (Stores Ref. 10A/13789) and the receiver on mountings Type 210 (Stores Ref. 10A/13788).

3. The HF and MF aerial plugs on the transmitter are connected independently to the HF and MF plugs on the aerial plugboard (Stores Ref. 10H/681) which stands on top of the cabinet Type 20. The socket on the aerial lead-in is placed on one of the two central plugs on the board appropriate to the frequency range in use, i.e., on the HF plug on ranges 2 and 2a and on the MF plug on range 3. The aerial may be earthed at the plugboard by placing its lead-in socket on one of the EARTH plugs.

4. A socket Type 175 (Stores Ref. 10H/425) is engaged with transmitter plug E, and pins 13 and 14, and 15 and 16, of the socket are shorted together. This short-circuiting is necessary in order to complete the circuit to the starter of the HT power unit and to maintain the receiver HT power supply when using D/F; these functions are performed inside the aerial selector switch Type J in aircraft installations.

5. The loop aerial (aerial loop Type 3, Stores Ref. 10D/10594) is normally connected to the navigator's receiver in this installation, but a socket is provided in the cabinet Type 20 for its connection to the wireless operator's receiver if necessary. A terminal block to which a wireless operator's visual indicator can be connected is also fitted in the cabinet.

6. An external aerial ammeter (Stores Ref. 10A/12667) is installed in the cabinet to show the transmitter aerial current on ranges 2 and 2a. The M/F aerial current is read on the meter M2 incorporated in the transmitter.

7. Both power units for the T.1154N/R.1155N installation stand on a shelf underneath the cabinet Type 20. Two resistance units Type 52A (Stores Ref. 10W/16024) are shown in the input circuit of the LT power unit Type 35A. These are adjusted to drop the applied voltage to 18 volts as read across the terminals marked yellow and black, with the batteries on charge. In later installations they are replaced by a voltage regulator Type 33 (Stores Ref. 5U/3061), the coloured terminals of which are connected to the terminals correspondingly coloured on the terminal blocks. Since the input to the HT power unit does not pass through the resistance units, it is important that the

R E S T R I C T E D

supply sockets of the two power units are not interchanged and the leads are made of such a length that this cannot be done.

Intercomm. facilities

8. The output from the receiver R.1155N is taken through the panel Type 192 (Stores Ref. 10D/13336) to the ABC switch and output transformer of the amplifier A.1134A (Stores Ref. 10U/90) and so to the wireless operator's intercomm. socket. A description of the amplifier A.1134 (similar to the A.1134A except that the latter is for low-impedance output) is given in A.P.1186, Vol. 1, Sect. 4, Chap. 2, but the facilities available in the three positions of the ABC switch are repeated below for reference.

(1) Position A.—Wireless operator is isolated from intercomm. system. Rest of crew have full intercomm. facilities and do not hear wireless signals from R.1155N. They have R/T facilities on the TR.1133. The operator cannot transmit R/T on the T.1154N as his microphone is disconnected from the input of the amplifier A.1134A.

(2) Position B.—Wireless operator is brought into intercomm. circuit and all members of crew hear wireless signals from R.1155N. All the crew have R/T facilities on TR.1133.

(3) Position C.—Same as position B, plus R/T transmission on T.1154N for all members of crew.

9. A switch box Type B (Stores Ref. 5C/543) is mounted on the operator's desk adjacent to his intercomm. socket and has two positions, I/C and D/F. When at I/C the facilities are as described above. At D/F the switch isolates the operator from the intercomm. system and enables him to hear and identify signals from the navigator's receiver, provided the navigator has placed a similar switch provided for him at D/F.

10. A separate mic-tel socket for the wireless operator is fitted in the cabinet Type 20 and is used in conjunction with a switch (Stores Ref. 10F/11714) in the cabinet. When this switch is at G/P the operator receives only wireless signals, but can still modulate the transmitter T.1154N for R/T (provided the ABC switch on the A.1134A is at C), his microphone circuit being unaffected. With the switch at I/C he has the normal facilities through the A.1134A, but cannot receive signals from the navigator's receiver.

11. The power supplies for the A.1134A are mounted on the shelf underneath the cabinet Type 20, together with the power units for the T.1154N/R.1155N installation. They consist of two 2-volt 20 amp. hr. accumulators (one spare) for L/T, and a power unit Type 173 (Stores Ref. 10K/293) providing 120 volts for HT. This is a vibrator unit, operated from the 24-volt D.C. supply. It is described in A.P.1186D, Vol. 1, Sect. 8, Chap. 1. An external switch Type 894 (Stores Ref. 10F/13236), is provided for the amplifier power supplies and interrupts both the LT circuit and the input to the power unit Type 173. The switch on the amplifier itself is always left in the ON position.

Navigator's receiver

12. The navigator's receiver R.1155A, B, or F is fitted in the wheelhouse. It has its own power unit Type 35A which is switched on and off remotely by the master switch of the T.1154N. A pilot lamp glows when the power unit is running and delivering its LT output to the receiver. The 24-volt circuit through the coil of the starting relay in this power unit passes via the contacts of a relay Type 220 (Stores Ref. 10F/494); these contacts are normally closed. The operating coil of the relay is connected in parallel with the starting relay of the HT power unit Type 33B of the transmitter T.1154N. When the HT power unit is started, therefore, the coil in the relay Type 220 is energized and the relay contacts break, thus stopping the power unit of the navigator's receiver and preventing damage to the receiver by the transmissions taking place on an adjacent aerial. A separate sense aerial is provided for the navigator's receiver.

13. Signals from the navigator's receiver are passed to his intercomm. socket through an impedance matching unit Type 111 (Stores Ref. 10A/13157), because the receiver output circuit is designed for high-impedance phones; and the types now in general use are of low impedance. This matching unit is not required with the wireless operator's receiver R.1155N, as the output from that instrument reaches his telephones through a transformer in the A.1134A, which is designed for a low-impedance output.

14. The navigator has a switch with which he can disconnect his telephones from the intercomm. system and receive only wireless signals (switch at D/F). If it is desired that

R E S T R I C T E D

62. An underside view of the chassis is given in fig. 16. The aerial circuit, anode circuit, and local oscillator coils, associated condensers and resistances, and the wafers wr-wf, xr-xf, yr-yf, and zr-zf of the frequency range switch FS are contained inside the large screening case at the bottom of fig. 16. Near the top edge of this container and, reading from left to right, are the adjustment ports for the trimmer condensers C_{59} , C_{70} , C_{68} , C_{71} , C_{72} , C_{63} , C_{64} , C_{65} , C_{62} , C_{66} , C_{59} , C_{60} , C_{61} , C_{58} , and C_{57} . The location of components on the underside of the chassis and within the screening can is shown in detail in fig. 17.

63. The additional filtering components included in the receivers types R.1155A and R.1155B are shown in the two illustrations, figs. 18 and 19. These illustrations are respectively, chassis upper deck and chassis underside views of the R.1155B and show the complete arrangements for suppression of M.F. broadcasting and radar interference. There is only a limited number of receivers in service containing M.F. suppression only and as the components, with one exception, are in the same relative positions in both types it is unnecessary to give illustrations of both.

64. Referring to fig. 18 the screening can (1), mounted over the three D.F. aerial coil assemblies on the upper side of the deck, contains the grid rejector filter unit, comprising a coil L_{33} , with a condenser C_{113} . In the R.1155A this can also contains a condenser C_{112} , and a resistance R_{71} . In the R.1155B these two components are located in the H.F. coil box under the deck and are connected between the choke HFC_5 and the switch section FS_{xr} . The choke HFC_5 connected between the aerial tuning condenser C_{58} and the control grids of V_1 and V_2 is mounted on a bracket adjacent to the top caps of V_1 and V_2 . The illustration of fig. 19 shows the H.F. coil box with the cover removed to enable the positions of these components to be indicated.

65. When using figs. 15 to 19 in connection with the R.1155L and R.1155N, paras. 34 and 35 should be consulted with regard to the removal, re-positioning, or addition of the items affected by the altered frequency ranges of these models.

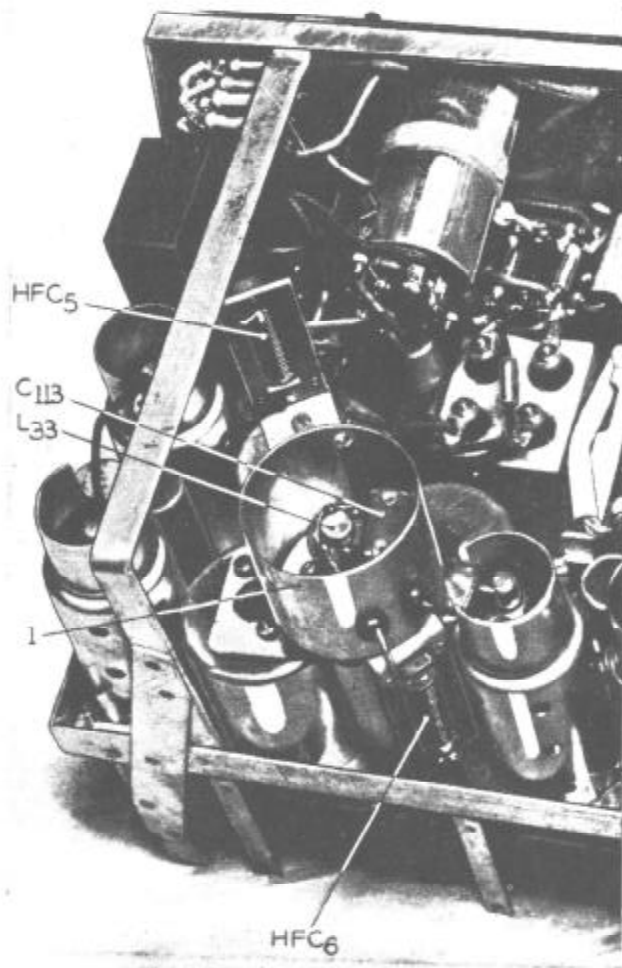

FIG. 18.—R.1155B CHASSIS, UPPER DECK

INSTALLATION

66. The following notes on the installation of the receiver duplicate, to some extent, the installation paragraphs included in Chap. 1, on the transmitter T.1154. This is unavoidably due to the interdependence of the transmitter and receiver when used in aircraft. From the typical installation diagram given in fig. 21 it will be realised that the transmitter is the main focal point of the wiring. The power unit connectors, and also the fixed and trailing aerials and connections from the receiver, plug into the transmitter. In laying out the equipment in the aircraft the receiver is placed in a convenient position for operation and where possible it is at desk level. The transmitter is mounted above or to one side of the receiver. The tuning scales of the receiver are to be easily visible and the controls accessible to the operator.

Receiver position

67. The receiver is normally positioned horizontally, but if space is limited it may be mounted vertically. The receiver is secured by mountings, type 54, and as these will be 90 deg. out when the

receiver is mounted vertically, a sponge rubber pad (mounting, type 55) may be inserted between the table and the bottom of the receiver. The receiver may be either table-mounted or back-mounted, depending upon the aircraft layout. From $1\frac{1}{2}$ in. to 2 in. is left between the receiver and the table or between the transmitter and the receiver (if mounted one above the other) to permit freedom of movement for the suspension fittings. Clearance around the receiver and transmitter cases should be sufficient to allow for removal and replacement of plugs and sockets and of the chassis. The transmitter case retaining screws must also be accessible. The equipment is not provided with internal illumination and is to be put in such a position that the natural illumination is good. For night work artificial illumination is provided and this is adjustable for direction and intensity.

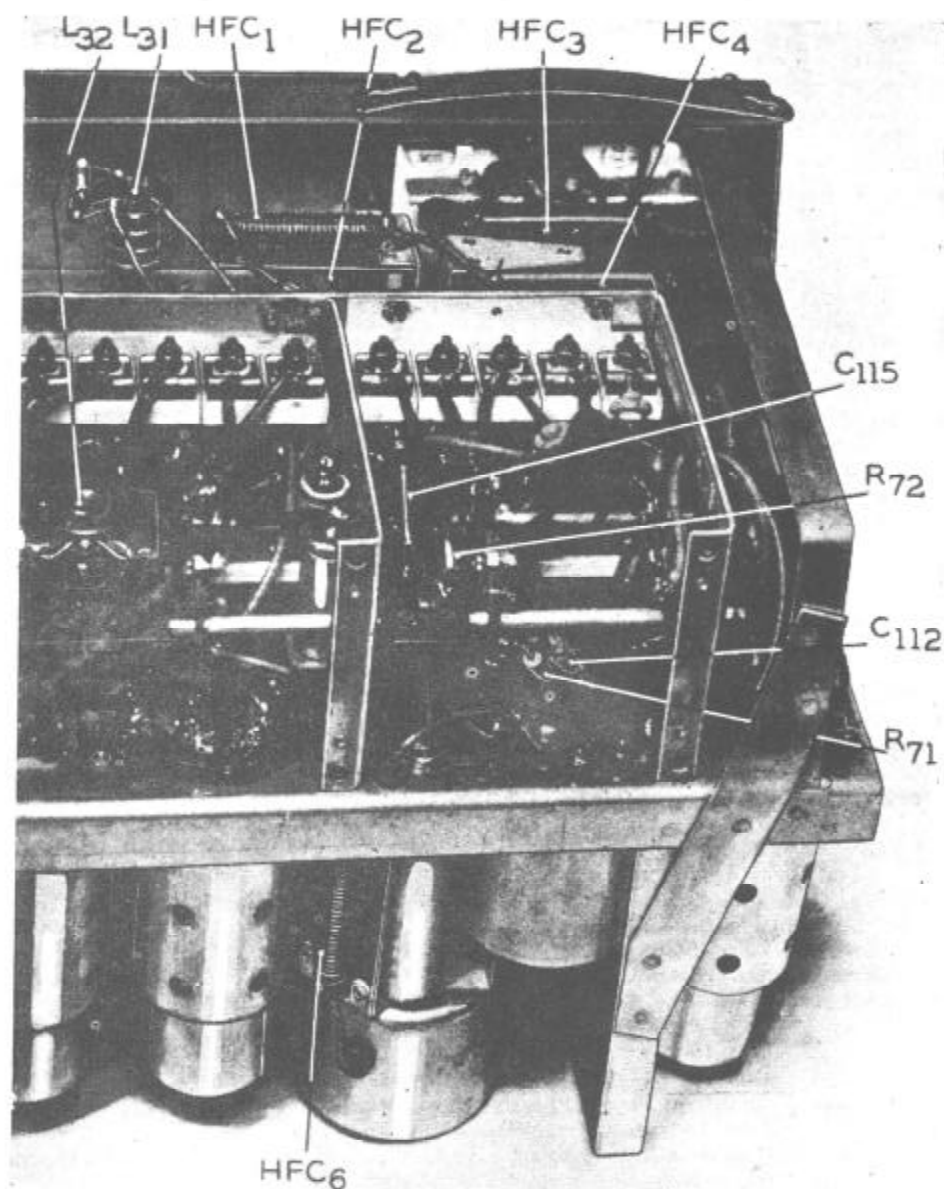

FIG. 19.—R.1155B CHASSIS, UNDERSIDE

Power unit position

68. The H.T. and L.T. power units, the latter of which is used to supply the receiver, are placed in an accessible position. Instructions on the installation of the power units, power cables and fuses, the L.T. dropping resistors, types 47 and 52 or 52A and the positioning of apparatus with respect to the aircraft compass, are given in Chap. 1 of this publication dealing with the transmitter T.1154 group. The receiver should be at least 24 in., and the visual indicator at least 18 in. from the compass to ensure negligible interference.

Aerial switch position

69. The aerial switching unit, type J, or the aerial plug board, which may be used as an alternative to the switching unit, is positioned between the transmitter and the aerial lead-in points so that the "run" of the aerial leads is clean and short. Instructions on the switch unit, the aerial plug board, internal aerial leads and other relevant details are given in Chap. 1.

D.F. loop aerial and impedance matching

70. The D.F. circuits of the receiver have been designed to work with a D.F. loop, type 3, which has a nominal inductance of 100 μ H and a self-capacitance, when installed, of 20 μ F. When loops having constants widely differing from these figures are used, it is necessary to use an impedance matching unit with a series or shunt coil between receiver and loop.

71. Two small condensers C_{106} and C_{104} , the latter adjustable, are contained within the plug type 209 which connects the D.F. loop to the receiver. The condenser C_{104} should be adjusted for maximum sensitivity. The fixed condenser C_{106} should be wired in circuit only if the length of low-loss cable between loop and receiver is less than 12 ft. The position of the adjustment of C_{104} can be seen on the diagram of the plug type 209 in fig. 22. The screwdriver used for adjusting C_{104} should have an insulated shaft to prevent short-circuiting to the receiver metal casing.

72. The procedure for matching the receiver input to the capacitance of the loop aerial lead is as follows:—

- (i) Set the aerial switch, type J, to D.F. (If the aerial plug board is in use set the plug marked FIXED AE to the group marked H.F.) As no D.F. interlock is provided by the aerial plug board care must be taken to avoid transmission when the receiver master switch is in the D.F. positions. Set the receiver master switch MS to FIGURE-OF-EIGHT.
- (ii) Tune receiver to suitable signal on range 3 at the 1,500 kc/s end of the scale, and turn the loop to a position giving *maximum* signals in the telephones.
- (iii) Adjust the trimmer condenser C_{104} to the position which gives maximum signals. Observe the tuning indicator V_{10} for minimum shadow during this operation.
- (iv) Remove the loop plug, type 209, from the receiver and note the position of the rotor plates in the condenser C_{104} . If it is found that the plates are in a position between maximum and minimum capacitance the adjustment is satisfactory and the plug should be replaced.

Circuit Ref.	Valve Type	Base Connections
V_1, V_2	VR99A	
V_3, V_5, V_6	VR100	
V_4	VR99	
V_7, V_8	VR101	
V_9	VR102	
V_{10}	VI 103	

FIG. 20.—VALVE CONNECTIONS

This table should be read in conjunction with fig. 21 INSTALLATION SCHEDULE

Item No.	Stores Ref.	Description	Item No.	Stores Ref.	Description	Item No.	Stores Ref.	Description	Item No.	Stores Ref.	Description
GENERAL WIRING											
2	5E/1364	Cable, Ducl 19 or Ducl 37	36	Special	Ae. fairlead c/w arr. type C	69	10A/12148	Impedance matching unit, type 12, or	109	10H/320	Socket, type 136
4	5E/1365	Cable, Ducl 4	38	10B/8235	Ae. wire, stainless steel	72	10A/12247	Impedance matching unit, type 15	110	10H/322	Socket, type 137
6	5E/1362	Cable, Ducl 4	40	10B/8093	Ae. insulator, type 16 (lead in) or 49 (lead in)	73	10A/7741	Key, morse, type F	113	10H/428	Socket, type 168
8	5E/1360	Cable, Unicel 19 or Unicel 37	42	10B/11457	Ae. insulator, type 17 (strain) or 18 (strain)	75	Special	Label	115	10H/429	Socket, type 170
10	5E/1358	Cable, Unicel 4	44	10B/8097	Ae. insulator, type 17 (strain) or 18 (strain)	78	10A/13078	Lampholder or Lampholder, type 61	116	10H/431	Socket, type 171
11	5E/1348	Cable, Dumet 4	45	10B/8994	Ae. insulator, type 17 (strain) or 18 (strain)	79	10A/12954	Mounting, anti-vibration, type 119	117	10H/423	Socket, type 172
12	5E/1351	Cable, Trimet 4	46	10B/9121	Ae. insulator, type 17 (strain) or 18 (strain)	80	10A/12421	Mounting, type 51	118	10H/424	Socket, type 173
13	5E/1353	Cable, Quadramet 4	47	10B/468	Ae. insulator, type 17 (strain) or 18 (strain)	82	10A/12422	Mounting, type 52	119	10H/425	Socket, type 174
14	5E/2069	Cable, Sextocorem, No. 1	48	10B/9121	Ae. insulator, type 17 (strain) or 18 (strain)	83	10H/9872	Mounting, type 51	120	10H/435	Socket, type 175
15	5E/2067	Cable, Octocorem, No. 1	49	10B/7298	Ae. insulator, type 17 (strain) or 18 (strain)	84	10H/433	Plug, type 101	122	10H/1498	Socket, type 299
16	5E/2068	Cable, Octocorem, No. 2	52	10B/7706	Ae. weight, bead, type No. 1 or 2	85	10H/434	Plug, type 209	123	10H/2206	Socket, type 359
17	5E/2033	Cable, Duradio, No. 20	53	10B/8478	Ae. weight, bead, type No. 2	86	10H/451	Plug, type 210	125	5K/1058	Terminal, 2 B.A., type A, spring type
18	5E/758	Cable, Uniplugmet, No. 1	57	5C/430	Ae. weight, bead, type No. 1 or 2	87	10H/8516	Plug, type 217	W. T. REMOVABLE EQUIPMENT		
20	5E/1362	Cable, Ducl 4	58	5C/432	Ae. weight, bead, type No. 1 or 2	88	10H/8516	Plug, type 68	128	10A/12227	Ammeter, H.W., 0-4 amps, type A or Ammeter, thermo.
21	5E/130	Cable, Unisheath 7	60	10A/12427	Block, mounting, type 1	89	10H/1518	Plate, anchorage, type 1	131	10E/542	0-4 amps, type D
22	5E/86	Cable, Uniflex 19 red braided spark 7	61	10A/12428	Block, mounting, type 2	90	10A/12436	Resistance unit, type 47	133	10A/13249	Box, valve stowage
23	5E/82	Cable, H.T. Uniflex, No. 1	63	10C/564	Condenser, type 764	91	10W/2221	Resistance unit, type 52A	134	10H/1938	Cover, protective
26	5K/912	Cable end, O B.A.	67	10Q/2	Indicator, visual, type 1	92	10W/2221	Switch unit, type J, or Aerial plug board	135	5C/462	Dummy socket block
27	5K/911	Cable end, 4 B.A.	69	10B/7298	Ae. weight, bead, type No. 1 or 2	94	10W/2221	Switch unit, type J, or Aerial plug board	136	5L1150	Lamp, instrument
28	5K/910	Cable end, 6 B.A.	70	10B/7706	Ae. weight, bead, type No. 1 or 2	96	10F/126	Switch unit, type J, or Aerial plug board	138	5L1898	Lamp, filament, 12-v., or 24-v.
31	5K/1810	Cable end hook type, crimping, Uniflex cable	71	10B/8478	Ae. weight, bead, type No. 1 or 2	97	10H/681	Switch, type 170 S.P.C.O. or 1 unit	139	10A/13787	Mounting, type 209
34	5K/1073	Sleeve, identification, Uniflex cable	72	5C/430	Ae. weight, bead, type No. 1 or 2	98	5C/543	Switch, 2 amp., miniature S.P.C.O.	140	10A/13788	Mounting, type 210
			73	5C/432	Ae. weight, bead, type No. 1 or 2	99	10F/11714	Switch, type 9, S.P. 2-way, or (12-v.) or (24-v.)	143	10K/13064	Power unit, H.T., type 32E, or Power unit, H.T., type 33B
			74	5C/432	Ae. weight, bead, type No. 1 or 2	101	10H/1276	Relay, type 265, (12-v.) or (24-v.)	145	10K/13065	Power unit, L.T., type 34A, or Power unit, L.T., type 35A
			75	5C/432	Ae. weight, bead, type No. 1 or 2	102	10F/752	Relay, type 258 (24-v.)	150	see concise details sheet	Receiver, R.1155 series
			76	5C/432	Ae. weight, bead, type No. 1 or 2	104	10F/493	Relay, type 219, or Relay, type 200	154	10K/13066	Transmitter, type T.1154 series
			77	5C/432	Ae. weight, bead, type No. 1 or 2	106	10H/494	Socket, type 40			
			78	5C/432	Ae. weight, bead, type No. 1 or 2	107	10H/8531	Socket, type 63			
			79	5C/432	Ae. weight, bead, type No. 1 or 2	108	10H/11051	Socket, type 135			

- (v) If it is found that the rotor plates are fully meshed it is an indication that insufficient capacitance adjustment is obtainable and additional capacitance should be added by removing the insulated covering from the leads running across the paxolin strips from the lower pair of tags to the top pair of tags, and by soldering the leads to the middle pair of tags adjacent to the leads.
- (vi) If examination shows that the rotor plates are in the position of minimum capacitance it is an indication that too much capacitance is in circuit. The additional capacitance of the fixed condenser C_{106} should be removed by reversing the procedure outlined in (v) above. Unsolder the connecting wires from the middle pair of tags and cover the wires with suitable insulation to prevent contact with the middle pair of tags.

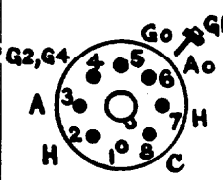
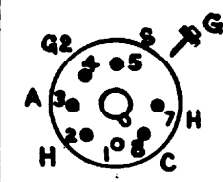
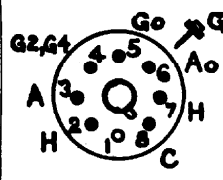
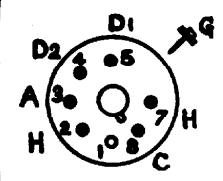
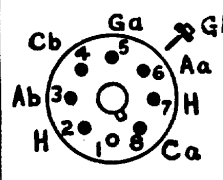
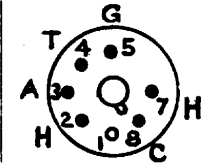
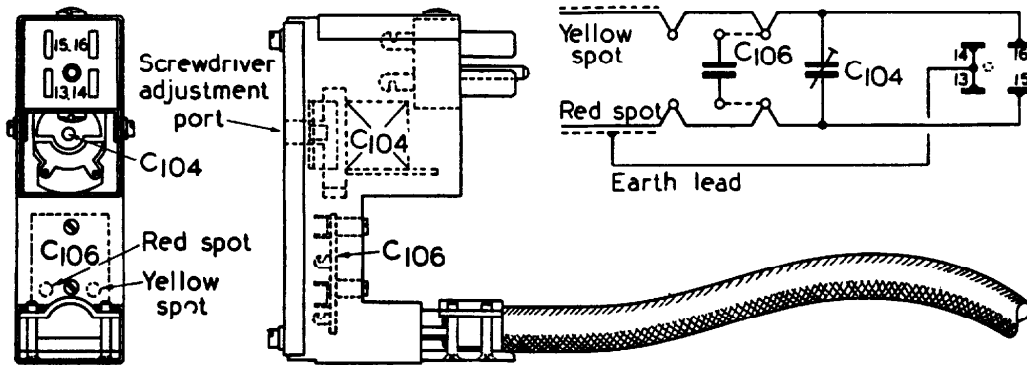

FIG. 22.—PLUG, TYPE 209

73. When a loop aerial type 1 is installed, an impedance matching unit, type 12, is used. When the receiver is installed on Hampden aircraft fitted with the retractable loop, an impedance matching unit, type 13, is used. When installed in aircraft fitted with the Bendix type loop, a matching unit, type 15, is used. The position of the impedance matching unit, with the maximum permissible length of cable between the loop and the receiver, is indicated in the installation schedules. The lengths between loop and matching unit, when installed, and between matching unit and receiver must, naturally, depend upon the position of the matching unit. In paras. 74 and 75 general principles governing the position are given.

74. On installations using the loop aerial, type 3, the length of cable connector Duradio No. 20 fitted with plug, type 209, and socket, type 63, should not be less than 6 ft. nor more than 20 ft. On installations using the loop aerial, type 1, the length of cable connector Duradio No. 20 should not be less than 5 ft. nor more than 18 ft. The matching unit should, preferably, be as near to the loop as possible. The position of the matching unit, when the Hampden retractable loop is used, should be as near the loop as possible and the position of the unit affects the maximum permissible length of cable. The length of Duradio No. 20 between the loop and the receiver should not be less than 4 ft. If the matching unit is not more than 7 ft. from the receiver a maximum total length of 22 ft. from loop to receiver is permissible. If the unit is not more than 3 ft. from the loop, the cable should not exceed 18 ft. total length, from loop to receiver.

75. When the Bendix loop is installed the matching unit, type 15, should be, preferably, as near as possible to the receiver. The length of Duradio No. 20 between loop and receiver should not be less than 4 ft. If the matching unit is not more than 6 ft. away from the receiver, the total length of cable from receiver to loop should not exceed 20 ft. If the unit is not more than 2 ft. from the loop, the total length of cable between receiver and loop should not exceed 17 ft.

Fixed aerial input

76. The fixed aerial input to the switching valves V_1 and V_2 is adjusted, on installation, by inserting a screwdriver into the small port on the right-hand side of the master switch MS. This is indicated on fig. 1 as C_{54} . Once adjusted, the condenser needs no further attention. An insulated screwdriver should be used in order to avoid the possibility of short-circuiting the trimmer to earth. The procedure is as follows:—

- (i) Set the aerial switch, type J, to D.F. (If plug board in use set the plug marked FIXED AE to group marked H.F.) Set the meter deflection switch S_2 to HIGH and receiver master switch to FIGURE-OF-EIGHT.

- (ii) Tune the receiver to a suitable signal on range 4 and rotate the loop to a position which gives the *minimum* signals in the telephones. The signal selected should be one the bearing of which remains constant. This may be checked by turning the master switch to VISUAL and noting that the needles of the visual indicator remain steady. The volume control R₆ should be adjusted to give the lowest possible signal strength, consistent with accurate observation, during this and other adjustments.
- (iii) Set the receiver master switch to BALANCE and adjust balance control R₅₁ and meter amplitude control R₂₃ to a position which causes the visual indicator needles to intersect along the white centre line on the dial face.
- (iv) Return the receiver master switch to FIGURE-OF-EIGHT and rotate the loop 30 deg. from the position previously obtained for (ii) above.
- (v) Operate the aural sense switch S₂ to L and R and hold the switch to the side which gives the *weaker* signal.
- (vi) With the aural sense switch held in the position selected as at (v) adjust the trimmer C₅₆ so that minimum signals are obtained. Observe the tuning indicator V₁₀ during this operation as correct adjustment is indicated by *maximum* shadow.

The visual indicator, type 1

77. It is usual to install two visual indicators, type 1, one on the pilot's instrument panel for "homing" purposes and the other in a convenient position for the operator of the receiver and D.F. loop. These indicators are provided with a dim, but independent, illumination so that they may be used at night. The indicators are mounted on a sprung panel, or otherwise protected against jars and vibrations, as their movements are extremely fragile. The methods of wiring to the visual indicator when either one or two of these instruments is installed are shown as part of the typical installation diagram, fig. 21.

78. The mounting, type 119, is used with the visual indicators, and filament lamps, jack, type G.P.O. No. 3 (12 volts) or G.P.O. No. 3 (24 volts) with lampholders, type 61, are provided when required. The following points should be noted when fitting the visual indicators:—

- (i) The instruments are mounted in the retaining strap so that they are suspended horizontally. The side brackets of the mounting, type 119, are adjusted as necessary. A minimum clearance of $\frac{1}{32}$ inch is allowed between the face of the instrument and the rubber cushion of the mounting.
- (ii) Not less than 9 in. of loose cable is left between the indicator and the first cable fixing point.
- (iii) The instrument retaining strap is tightened by means of a screw.

Setting up the D.F. loop

79. The polarity of the leads connecting the visual indicators to the receiver must be correct as indicated in fig. 21. This must be carefully checked. Similarly, the connections from the receiver to the D.F. loop must be checked. If the loop, type 3, is used and has been installed with the red end of the cradle toward the rear and the cursor reading at 180 deg. on the black marking of the scale ring, then the sense of the visual indicators should be correct. If a D.F. loop, other than the type 3, is used it should be stated quite clearly on a label in the aircraft how the loop scale must be adjusted so that the sense is correct. The following procedure should be adopted to ensure that the sense is correct:—

- (i) Turn the master switch to FIGURE-OF-EIGHT. Tune the receiver to a suitable signal in range 3 or 5. This signal should be definitely identified and the relative position of the transmitting station, with respect to the aircraft, known.
- (ii) Set the loop to the approximate bearing of the station and finally adjust for minimum or zero signal to give the exact bearing.
- (iii) Turn the meter deflection sensitivity switch S₂ to Low. Hold the aural sense switch S₂ to R and reduce the loop scale reading. The signals should rise in strength.
- (iv) If the signals decrease in strength it will indicate that the installation has been incorrectly made and the loop and associated circuits should be checked.
- (v) The above test should be repeated with the master switch at VISUAL. If sense is *correct*, the visual indicator meter needles will swing to the *right*.

After installation of a new apparatus, when making a test flight, the routine for visual D.F. sense discrimination should be carried out in order to determine whether the loop connections are correct. It is necessary to check on a station the position of which relative to the aircraft is known.

Loop centre tap

80. The receiver is designed to work on loops having no centre tap. As the receiver aerial coils are centre-tapped to earth, the loop centre-tap is unnecessary. Since it is possible that the tap may not have been removed with new installations a check should be made as follows:—

- (i) Remove loop plug at receiver and connect a test-meter, type E across contacts 15 and 16 using the OHMS range. This should give a low resistance reading.
- (ii) A reading should then be taken from contact 15 or 16 to 14 and 13. Open circuit should be indicated.
- (iii) If a reading is obtained at (ii) it indicates that the loop has not had the centre tap removed, or that one side is earthed. The necessary action as indicated in para. 81 should be taken in these circumstances.
- (iv) Adjust the loop lead capacitance (*see* para. 72).

81. The following is the sequence of operations for the removal of the loop centre tap:—

- (i) Remove the fabric strips from around the centre seam of the streamlined housing.
- (ii) Remove and retain the six screws securing the tail and centre section of the housing.
- (iii) Withdraw the tail portion of the housing. The loop winding will now be exposed.
- (iv) Identify the loop winding inner terminations and remove the connection from one winding termination, inner, to the metal centre piece.
- (v) Remove the connection from the other winding termination, inner, to the spill on the corner fixing screw.
- (vi) Connect the winding terminations, inner, by a short length of 18 s.w.g. tinned copper wire (Stores Ref. 5E/1779) encased in insulating tubing, grade E (Stores Ref. 5F/1910).
- (vii) Disconnect the loop plug from the receiver and using a test-meter, type E, check the loop circuit as follows:—
 - (a) Plug the negative lead into the OHMS socket and connect the test meter between the loop winding and earth. The test-meter should not show a deflection.
 - (b) Connect the test meter across the loop winding outer terminations and it should register full-scale deflection.
- (viii) Replace the tail piece of the loop housing and secure it by the six screws.
- (ix) Re-seal the centre seam, using 2 in. wide cotton tape (Stores Ref. 32B/409), approximately 10 ft. long, and special adhesive, Boscolyn lacquer (Stores Ref. 33C/590).

Navigator-operated receivers

82. In certain aircraft an additional receiver is installed for the exclusive use of the navigator for D.F. purposes. The D.F. loop which is normally connected to the communications receiver is now connected to the navigator-operated receiver. The existing loop connector is dispensed with and a new connector fitted, the length of this varying to suit individual installations. The typical installation diagram of fig. 21 includes this navigator-operated receiver.

83. The visual indicator, previously located and wired in a position accessible to the W/T operator, is removed and mounted at the navigator's station, a suitable connector being used. The visual indicator is connected to the navigator-operated receiver. The visual indicator provided for the use of the pilot will remain. A dummy socket (Stores Ref. 10H/1938) is provided for the purpose of blanking out the D.F. loop and visual indicator connections on the communications receiver. Existing remote controls may have to be repositioned or removed and where no remote controls exist these may have to be provided.

84. To provide for sense indication a separate fixed aerial is required for use with the navigator-operated installation. In certain circumstances it may be necessary to utilise one of the existing fixed aerals and a change-over switch.

85. In order to overcome any difficulty which might arise over signal identification, means are provided to enable signals to be switched from the navigator back to the W.T. operator. This is accomplished by means of two switches, type 170, suitably wired. One switch is controlled by the navigator whilst the other is controlled by the W.T. operator. When the navigator's switch is set to the D.F. position his telephones are connected to the output of the additional receiver. Should it be necessary for the W.T. operator to identify the signal, the operator's switch is set also to the D.F. position. Normal intercommunication facilities are established when the switches are set to the I/C position.

86. The modifications to the power unit, to enable the additional power for the navigator-operated receiver, entail the fitting of a relay unit to the L.T. power unit and a single pole socket to the H.T. power unit. These modifications are described in Chap. 1 of this publication. It is recommended that V₁, V₂, and V₃ be removed from the *wireless operator's* receiver to reduce the load on the L.T. power units when two receivers are installed.

87. It has been found that in certain navigator-operated receivers, type R.1155, some valves are not connected to the H.T. supply. This is due to the omission of a lead between pins Nos. 5 and 7 of the socket, type 299, which is fitted at the receiver end of the cable between the L.T. power unit and the receiver. If, upon examination, the socket, type 299, is found deficient in this respect, the following procedure should be adopted:—

- (i) Withdraw the socket, type 299, from the receiver and remove its cover.
- (ii) Connect a 1 in. length of 18 s.w.g. tinned copper wire, encased in grade E insulating tubing, between pins No. 5 and No. 7.
- (iii) Replace the cover of the socket.
- (iv) Replace the socket in the receiver.

Power units

88. Installation instructions in connection with the airborne power units and the procedure for adjustment of the resistance unit, type 47 (12-volt) or type 52 or 52A (24-volt) which is connected between the aircraft electrical supply and the L.T. power unit, supplying the receiver L.T. and H.T., can be found in the chapter on the transmitter, type T.1154, Chap. 1 of this publication. Any of the L.T. power units listed in the concise details sheet at the beginning of this chapter may be in use, those bearing the suffix letter A being for use when a navigator-operated receiver is installed. Details of types 34A and 35A are as follows:—

Type	Stores Ref.	Input		Outputs				Rated Watts
				L.T.		H.T.		
		Volts	Amps.	Volts	Amps.	Volts	mA.	
34A	10K/13065	10.3	24	7	13	217	110	115
35A	10K/13066	18.5	12	7	13	217	110	115

The receiver D.C. feed varies according to the master switch position ranging from 48 mA at OMNI with volume control at a minimum to 69 mA or more at BALANCE or VISUAL with maximum setting of volume control.

OPERATION

89. The operation of the receiver will be facilitated by reference to fig. 1 which shows the front panel controls, plugs, and socket. The operator should first satisfy himself that all valve top cap connectors are making secure contact. The plugs and sockets should be securely engaged and the retaining bar should be in position on the posts provided. The receiver socket and plugs are grouped at the bottom right-hand corner and, from left to right, they are:—Socket SK₃, FROM LOOP AERIAL; plug P₃, TO VISUAL INDICATOR; plug P₁, FROM TRANSMITTER.

90. For communications reception the fixed aerial is normally used on the H.F. ranges 1, 2, and 2A, and the trailing aerial on the M.F. ranges 3, 4, and 5. By operating the aerial selector switching unit, type J, or the aerial plug board, the fixed or trailing aerial can be used on all ranges. This ensures continuity of communication should one of the aeriels become unserviceable. For D.F. the fixed aerial and loop aerial are used. D.F. reception, using visual and aural methods, is available on all ranges except range 1 and 2A. (In the R.1155C only, range 1 may also be used for D.F. purposes.) The operator should ensure that the correct matching unit, for the type of loop aerial being used, is installed, as specified in para. 73.

Controls

91. The receiver has three main communications controls:—

- (i) The tuning control with frequency-calibrated scales, the frequency being indicated by a pointer on the scale. The exact point of resonance is shown by a minimum shadow on the tuning indicator V₁₀. The scale colour code is based on that of the transmitter, type T.1154, frequencies outside the transmitter ranges being indicated in black, but see para. 56.

- (ii) The frequency range switch FS selects the desired range 1 to 5.
 - (iii) The master switch MS has five positions which perform the following functions:—
 - (OMNI). The R.F. and I.F. gain is manually controlled by the volume control, which actuates the ganged potentiometers $R_{s(1)}$ and $R_{s(2)}$. In this position of the master switch the potentiometer $R_{s(1)}$ is in circuit. This position is used for W.T. reception and for back-tuning between the transmitter and the receiver.
 - A.V.C. The R.F. and I.F. gain is automatically controlled. In this position of the master switch the potentiometer $R_{s(2)}$ is in circuit giving manual control over the A.F. gain. This position is used for R.T. reception.
 - BALANCE. This position is used in conjunction with the meter balance control R_{s1} for balancing the visual indicator before D.F. is carried out.
 - VISUAL. For homing by visual means. This position may also be used for taking bearings by visual means in lieu of the normal aural method.
 - ∞ (FIGURE-OF-EIGHT). For aural D.F. reception, using the switch S_3 for sense discrimination.
92. The receiver secondary controls are:—
- (i) INCREASE VOLUME (R_s)—Adjusts input to grid of V_3 when MS is at A.V.C. and adjusts bias of R.F. and I.F. stages when MS is at OMNI and FIGURE-OF-EIGHT.
 - (ii) HETERODYNE SWITCH (S_4)—Switches in the B.F.O. valve V_7 for C.W. reception.
 - (iii) METER AMPLITUDE (R_{m0})—Varies height of visual indicator needles when setting up to D.F. balance. May also be used for occasional adjustment of the needles on weak signals.
 - (iv) METER BALANCE (R_{s1})—Adjusted with MS at BALANCE and must not be adjusted with MS at any other position. Balance is indicated when two needles of the visual indicator intersect on the centre line.
 - (v) METER SENSITIVITY SWITCH (S_5)—Effects maximum deflection of visual indicator needles at 25 deg. off course for "homing" purposes (LOW) or maximum deflection of 10 deg. off minimum when taking bearings by visual indicator (HIGH).
 - (vi) METER FREQUENCY SWITCH (S_1)—Causes L.F. switching oscillator (V_1 and V_2) frequency to be either 80 c/s (HIGH) for W.T. or 30 c/s (LOW) for R.T.
 - (vii) AURAL SENSE SWITCH (S_2)—Spring loaded. Used for sense determination when aural D.F. reception is employed.
 - (viii) FILTER SWITCH (S_3)—Used to eliminate the switching frequency when monitoring visual D.F. and for elimination of aircraft electrical noises and also to reduce background noises when listening to R.T. transmissions from aircraft.

Setting up heterodyne oscillator

93. To bring the B.F.O. valve V_7 into operation for receiving C.W. the switch S_4 is used. It is first necessary to set up the heterodyne oscillator and this is accomplished as follows:—

- (i) Turn the aerial selector switching unit, type J, to the position M.F. ON FIXED or, if using an aerial plug board, connect the fixed aerial to M.F.
- (ii) Put the transmitter master switch to STAND BY and the receiver master switch MS to A.V.C.
- (iii) Switch on the B.F.O., using S_4 .
- (iv) The frequency range switch FS should be at range 3 and a convenient R.T. transmitting station tuned in until the minimum shadow is seen in the tuning indicator V_{10} .
- (v) Insert a screwdriver into the HET.ADJ. port giving access to C_{13} and slowly adjust the condenser until a suitable note is heard in the telephones. A variation of approximately 3 kc/s can be effected.

Back-tuning

94. In the absence of a crystal-monitor the "back-tune" method can be used to facilitate the setting up of the transmitter "spot" frequencies. The receiver frequency range switch FS is set to the RANGE in which the required transmitter frequency occurs. Set the receiver to the required frequency and set the master switch to OMNI. Set the volume control R_s about half-way. With the transmitter master switch at TUNE, press the morse key and swing the master oscillator dial until maximum signal strength, that is, minimum shadow, is indicated in the tuning indicator V_{10} .

adjusting the receiver volume control R_9 as necessary. Adjust the transmitter output in the normal manner and recheck the M.O. tuning by reference to the receiver tuning indicator V_{10} . Send a series of dots and observe flicker in V_{10} .

95. It will be realised that it is possible to set up the receiver exactly to a click-stopped "spot" frequency on the transmitter by means of back-tuning. The transmitter should first be independently tuned to the required frequency. Set the receiver frequency range switch to the required range in which transmitter frequency occurs. Set the receiver master switch to OMNI with volume control half-way. Set the transmitter master switch to TUNE, press the key, and adjust the receiver tuning for minimum shadow in V_{10} .

Note.—If the edges of light on the tuning indicator overlap during tuning operations, reduce the volume control. If the shadow cannot be reduced, increase volume control.

Normal communication

96. The aerial switching unit, type J, is turned to NORMAL (when using aerial plug board the fixed aerial is connected to H.F. and the trailing aerial to M.F.). The transmitter master switch is at STAND-BI. Turn up the receiver volume control until background noise is heard. Put the receiver master switch MS to OMNI and V_{10} should show a green light. Turn the receiver frequency range switch FS to the required range and adjust the receiver frequency. If working C.W., switch on the heterodyne by S_4 . Whilst sending signals a 1,200 c/s side-tone should be heard in the telephones. Listening-through can be tested, with the morse key up, by listening for signals or receiver background noise. The tuning indicator V_{10} will flicker to dots and dashes when transmission is taking place if the receiver is tuned to the same frequency as the transmitter.

Note.—In heavy static, or thunder conditions, the fixed and trailing aeriels should be earthed. This condition is met by turning the aerial selector switching unit, type J, to EARTH (when using an aerial plug board connect the plugs of both aeriels to the EARTH sockets provided). Reception is still possible, using ranges 2 to 5, in conjunction with the loop aerial. Turn the frequency range switch FS to the required range. Turn the master switch MS to FIGURE-OF-EIGHT and tune in the signal. Rotate the loop aerial to the position of maximum strength, noting the V_{10} shadow. Adjust the volume control.

D.F. bearings using visual indicator

97. Frequency ranges 3, 4, and 5 (occasionally 2) are used. On the R.1155C all ranges, including range 1, may be used. Only the *black* scale on the loop should be used. First, turn the aerial selector switch to D.F. or, if using aerial plug board connect the trailing aerial to M.F. and the fixed aerial to H.F. If an aerial plug board is fitted, care must be taken by the operator to see that the transmitter switch is at STAND-BI and that the key is not pressed. Turn the transmitter master switch to STAND-BI and the receiver frequency range switch FS to the required range. Turn the receiver master switch to OMNI.

98. Tune in the signal as for normal communication and adjust the volume to a low level. Turn the receiver master switch to BALANCE. Adjust the visual indicator needles by the meter balance control R_{51} so that they intersect exactly along the centre line on the dial face. If necessary, adjust the needles to a suitable working height by rotating the meter amplitude control R_{23} . Turn the meter sensitivity switch S_2 to HIGH. Turn the switch S_1 to HIGH for W.T. or LOW for R.T. and the filter switch S_6 to IN. Readjust balance by the meter balance control R_{51} . Turn the master switch MS to VISUAL. The indicator needles should now operate. Turn the loop aerial until the indicator needles intersect along the centre line on the dial face.

99. Check for sense by reducing the scale reading of loop. If indicator needles swing to the *right*, sense is *correct*. If to the left, sense is incorrect. When sense is correct, turn the loop back to the position on *black* scale, to which needles intersect along the centre line on the dial face, and note reading. If sense is incorrect, rotate through 180 deg. to determine bearing. The routine may be easily remembered by the "RRR rule":—Reduce reading; Right deflection; Right sense.

Homing, using visual indicator

100. The sequence of operations detailed in paras. 97 and 98, up to that in which the master switch MS is turned to VISUAL, should be carried out prior to the following. The loop is then set to loop scale reading zero, that is, athwartship. The meter deflection (sensitivity) switch S_2 is positioned at LOW and the master switch MS to BALANCE. The balance is readjusted by R_{51} and the master switch put to VISUAL. The pilot should now be asked to alter course until the needles intersect along the centre line on the visual indicator dial face. There may be occasions when it is not known whether the "homing" transmitter lies ahead or astern of the aircraft, and sense discrimination must then be carried out as described in the next paragraph.

101. After the aircraft has been set to a course which causes the needles to intersect on the centre line the course is off-set a few degrees to the left; if the station is ahead, the needles will intersect on the right; if the station is astern, the needles will intersect on the left and the course should be altered by 180 degrees. This sense discrimination may, if desired, be carried out by reducing the loop scale reading by, say, 10 deg. instead of altering the aircraft's course. Sense will be indicated in the same manner. Care should be taken to ensure that the loop is restored to zero after sense determination. During "homing," balance should be checked every ten minutes. If necessary, make adjustments to the meter amplitude R_{23} and re-check the balance after this operation.

102. It should be remembered that "homing" by visual indication is only in the nature of an "aid to navigation" and that normal navigation should not be neglected whilst it is being used. The aircraft should, for example, be prevented from drifting if there is a cross wind. The homing method, when properly used, will always bring the aircraft to the source of transmission, but unless the standard navigational methods are observed, the course flown may be increased, beyond the point-to-point distance, due to wind.

103. A method of off-setting the loop to the fore-and-aft line of the aircraft in order to traverse a true point-to-point course if possible, but this is dependent upon very accurate information as to cross wind, speed and direction. When flying over the home station the indicator needles will collapse for a few seconds, indicating that the station is directly below. After passing the station the sense will reverse and if the instructions given are observed the course of the aircraft can be reversed until the station is again directly below. When homing on a keyed transmitter, it is necessary to note that the indicator needles collapse symmetrically down the centre scale as the distant transmitter is keyed. If the needles do not collapse symmetrically it will indicate that signals are being received with interference and resulting false indication of course. When homing, signals should be monitored from time to time to ensure that the desired frequency is not subject to interference.

Aural D.F.

104. When using the aural method of D.F. the fixed aerial is disconnected, the loop being the sole source of signal pick-up. The meter switching circuits of V_9 are inoperative. Volume control is effected manually, the A.V.C. system being out of circuit.

105. The routine for aural D.F. is as follows:—The aerial selector switching unit is turned to D.F. or, when using the aerial plug board the trailing aerial is connected to M.F. and the fixed aerial to H.F. The range switch FS is turned to the required range and the master switch MS to OMNI. The meter deflection switch S_2 is placed at LOW and the required signal tuned in. The volume control is then readjusted and the tuning re-checked on the tuning indicator V_{10} .

106. The master switch MS is then turned to the FIGURE-OF-EIGHT position, the loop is swung to the position of *minimum* signal and the volume control adjusted to obtain a zero. The loop scale reading for this zero signal should be observed. To check for sense, reduce the scale reading of the loop, putting the sense switch S_3 to the R position. If the signal strength rises the sense is correct. If the signal strength decreases the sense is wrong, and the loop should be turned through 180 deg. and the zero signal setting noted. The L and R positions of S_3 permit the operation of V_1 or V_2 by applying H.T. to the screens. This, of course, brings in the fixed aerial signals for application to the loop aerial circuit.

PRECAUTIONS AND SERVICING

Ground testing

107. The following procedure should be adopted for ground testing the R.1155. Having set the aerial switching unit to the NORMAL position the frequency range switch should be placed at either range 1, 2, or 2A. The master switch is then positioned at either OMNI or A.V.C. Having turned the transmitter master switch to STAND-BY the L.T. power unit should start up and, in a few seconds, the tuning indicator should glow. The telephones are then inserted and the reception of signals checked.

108. To receive on the M.F. ranges 3, 4, and 5 the aerial switching unit is set to the position engraved M.F. ON FIXED AERIAL. If a check of D.F. reception is made the aircraft should be clear of all metal obstructions such as hangars, before verifying sense of bearings. To carry out this test the aerial switching unit should be placed to D.F. With the aerial switching unit in this position or in the EARTH position, the H.T. power unit should remain inoperative in all positions of the transmitter master switch.

109. On installations fitted with the aerial plug board, the fixed aerial socket must be connected to the H.F. plug in order to receive on the H.F. ranges 1, 2, and 2A. To receive on ranges 3, 4, and 5, the fixed aerial socket should be connected to the M.F. plug. When using visual D.F., it should

D.C. RESISTANCE TABLE

Component	Test Points	Resistance in ohms	Component	Test Points	Resistance in ohms
<i>I.F. Coils</i>					
L ₁₉ prim. sec.	V ₄ anode to R ₃₄ , C ₃₃	2 approx.	Range 4 input	FS xr1 to C ₄₀ , R ₄₅	6
L ₂₀ prim. sec.	V ₅ grid to R ₃₅ , C ₃₅	2 approx.	Range 5 input	FS xr1 to C ₄₀ , R ₄₅	57
L ₂₁ prim. sec.	V ₆ grid to R ₃₆ , C ₃₆	2 approx.	Aerial circuits		Less than 1 to earth
	V ₆ anode to R ₃₈ , C ₃₇	2 approx.			
	V ₇ diode to R ₃₉ , C ₁₁	2 approx.			
<i>B.F.O. Coil</i>			V ₄ input circuits		
L ₂₂	Fixed plates C ₁₃ to R ₁₈ , C ₁₇ or C ₁₅	5		V ₄ grid to C ₃₇ , R ₃₈ junction	
<i>A.F. oscillator trans.</i>			Range 1	Switch to Range 1	Less than 1
L ₂₃ prim.	V ₁ osc. anode to V ₂ osc. anode	7,970	Range 2	Switch to Range 2	Less than 1
L ₂₃ sec.	V ₁ osc. grid to V ₂ osc. grid	355	Range 2A	Switch to Range 2A	Less than 1
L ₂₃ 2nd sec.	P ₂ pins 7 and 8	331	Range 3	Switch to Range 3	3.5
<i>Anode chokes</i>			Range 4	Switch to Range 4	11.0
V ₁ , V ₂			Range 5	Switch to Range 5	78.0
L ₂₄	V ₁ anode to R ₄₀ , C ₄₁	550	V ₄ osc. circuit		
L ₂₅	V ₂ anode to R ₄₀ , C ₄₁	550		V ₄ osc. grid C ₃₅ (zf contact 12) to joint R ₃₅ , C ₃₄	
<i>A.V.C. choke</i>			Range 1	Switch to Range 1	Infinity
L ₂₆	V ₇ diode to C ₁₀₈ , R ₆₅	135	Range 2	Switch to Range 2	Infinity
<i>Visual meter chokes</i>			Range 2A	Switch to Range 2A	500
L ₂₆	V ₈ anode to C ₅ , R ₂₅	135	Range 3	Switch to R ₃	1,600
L ₂₇	V ₉ anode to C ₅ , R ₂₄	135	Range 4	Switch to R ₄	1,650
<i>Limiter diode choke</i>			Range 5	Switch to R ₅	0.5
L ₂₈	R ₇₀ , C ₂₀ to C ₄ , R ₂₃	135	H.F. Ranges 1 and 2		
<i>L.F. filter choke</i>			Ranges 2A, 3, 4, 5	FS zf12 to zf6	0.5
L ₂₉	S ₅ to earth	2,020	<i>Oscillator anode coil</i>	FS zf12 to zf6	Infinity
<i>Output transformer</i>			Range 3	C ₃₄ , R ₃₅ to C ₇₅	2.5
L ₃₀ prim.	V ₈ anode to pin 5, power plug P ₁	1,528	Range 4	C ₃₄ , R ₃₅ to C ₇₄	4.5
L ₃₀ sec.	P ₁ pin 6 to earth	1,063	Range 5	C ₃₄ , R ₃₅ to C ₇₃	8.5
<i>Aerial circuit</i>			<i>Oscillator anode coils tap check</i>		
Range 1 input	FS xr1 to C ₄₀ , R ₄₅	Less than 1	Range 1	FS zr6 to C ₃₅ or zf12	Infinity
Range 2 input	FS xr1 to C ₄₀ , R ₄₅	Less than 1	Range 2	FS zr6 to C ₃₅ or zf12	Infinity
Range 2A input	FS xr1 to C ₄₀ , R ₄₅	Less than 1	Range 2A	FS zr6 to C ₃₅ or zf12	500
Range 3	FS xr1 to C ₄₀ , R ₄₅	2	Range 3	FS zr6 to C ₃₅ or zf12	1,600
			Range 4	FS zr6 to C ₃₅ or zf12	1,600
			Range 5	FS zr6 to C ₃₅ or zf12	1.5

VOLTAGE TESTS, ETC.

Measure	Test Points	Voltage and Resistance
L.T. volts	Withdraw meter plug P ₂ Measure across contacts 4 and 5	6 to 7.5 v.
H.T. volts	Measure across contacts 4 and 6	200 v. approx.
<i>Standing bias on</i> V ₂ , V ₆ , V ₈ and V ₉	Remote end of R ₁₃ and chassis Vol. control to OMNI max. position	-3 v. M.F.
	Remote end of R ₁₃ and chassis Vol. control to OMNI max. position	-1.5 v. H.F.
D.C. resistance between H.T.+ and H.T.-	Withdraw P ₁ from chassis Measure between pin 5 and pin 8	9,500 ohms.
A.F. oscillator	Withdraw plug P ₂ Measure between pins 7 and 8 using A.C. range of Testmeter	28 v. at 30 c/s 35 v. at 80 c/s

COLOUR CODE

Wiring Red, H.T. positive
Yellow, H.T. negative
Blue, L.T. positive

Black, earth
Green, grids

w is aerial input
x is grid V

SWITCHES

y is anode V₂
z is grid and osc. V₄

A.P. 2548A VOL. I CHAP. 2

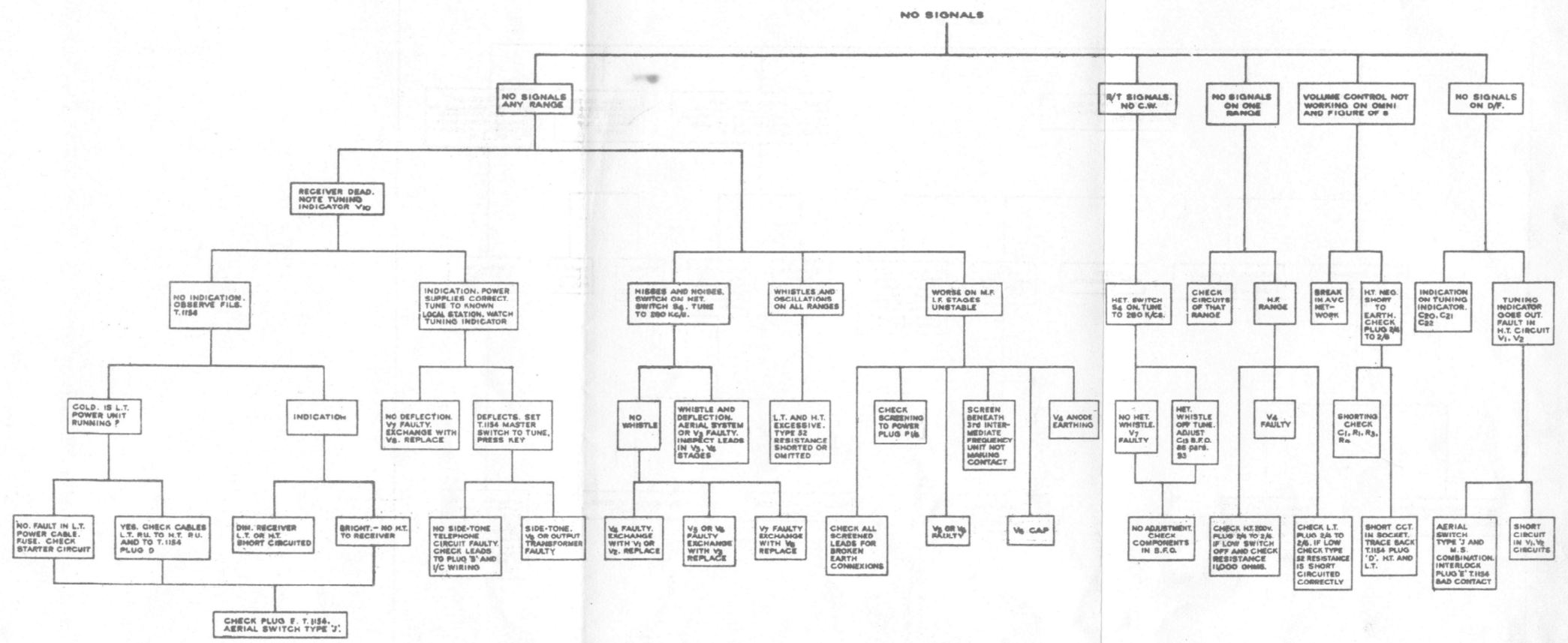

COMMUNICATION CIRCUITS — TROUBLE LOCATION CHART

TROUBLE WITH D/F.

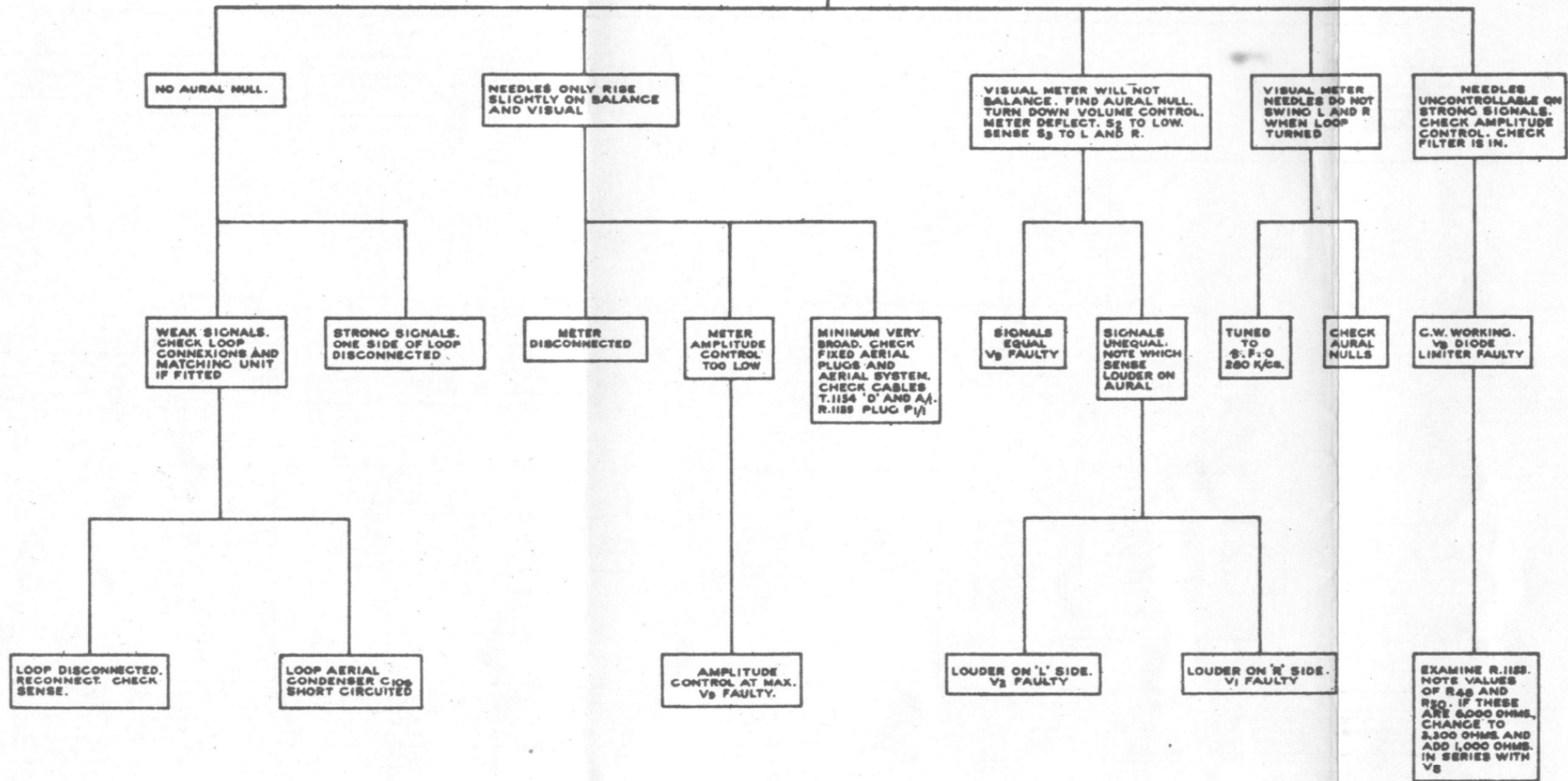

D. F. SWITCHING CIRCUITS — TROUBLE LOCATION CHART

be remembered that the aerial plug board does not break the H.T. power unit relay circuit in any position and therefore the transmitter master switch *must* be kept at STAND-BY.

110. When the aircraft nominal supply is 12 volts the minimum permissible voltage with the L.T. power unit running is 10.5 volts. When the aircraft supply is 24 volts the minimum permissible voltage with the L.T. power unit running is 21 volts. The minimum filament voltage permissible for normal functioning of the receiver is 5.7 volts. If reception fails or signals are weak, when the filament voltage is between 5.7 and 6 volts, the frequency changer valve V_4 should be renewed.

Starter trolley batteries

111. As the current drawn by the T.1154-R.1155 equipment will discharge the aircraft batteries very rapidly, ground tests are to be carried out using the larger batteries on a starter trolley. It is usual for equipment to be so arranged that plugging in the trolley starter service leads to the normal point automatically isolates the aircraft starter accumulator and connects the W.T. equipment to the trolley accumulator.

Visual indicator

112. Should either of the visual indicators, type 1, be rendered unserviceable, operation can be carried out with a single instrument. The windings are connected in series, and connections A and B, C and D on the unserviceable indicator should be short-circuited to enable the serviceable one to operate.

113. Water or dampness will affect the readings on the visual indicators if allowed to remain on the terminals of the instrument. The back of the indicators should therefore be wiped dry before use. Periodical observations should be made to check that the pilot's and operator's indicators are giving approximately equal readings. If not approximately equal the pair should be tested against a known serviceable indicator and the faulty instrument renewed. When carrying out these checks the receiver master switch should be in the BALANCE position.

Trouble location

114. Trouble location charts, figs. 23 and 23A, are included and these should assist in the rapid localizing of faults. Various circuit continuity tests are also included for the checking of burnt-out or deteriorated components. A necessary preliminary to the rapid solution of difficulties is a familiarity with the location of the various components and this will be assisted by the location diagram, fig. 17.

Test apparatus

115. Ground tests of the R.1155 are normally carried out by means of the test rigs, types 22 or 22A. For the use of civilian repair organizations and Maintenance Units a special test set, type 65, is provided for bench testing. This, however, is not a normal service issue. By means of this unit all the test conditions necessary for communications and D.F. reception can be simulated and are easily selected for each particular test by means of switches. The test rig, type 22, comprises a single panel carrying a visual indicator, four switches for selecting the test conditions, four plugs for connecting the unit to the receiver and power supplies, and terminals for the connection of a signal generator, output meter, and telephones. The test set, type 65, is described in Sect. 5, Chap. 18 of A.P.1186, Vol. I.

Valve data

116. The following table gives the type and function of each valve. All the valves are fitted with international octal bases. A diagram of the base connections is given in fig. 20.

Figure Ref.	Function	Type
V_1, V_2	Visual D.F. switching	Triode-hexode, V.R.99A
V_3	R.F. amplifier	Variable-mu H.F. pentode, V.R.100
V_4	Frequency-changer	Triode-hexode, V.R.99
V_5, V_6	I.F. amplifiers	Variable-mu H.F. pentode, V.R.100
V_7, V_8	A.V.C. and B.F.O. Second detector, visual meter limiter and output	Double diode triode, V.R.101
V_9	Visual meter switching	
V_{10}	Tuning indicator	V.I.103

Valve identification

117. The receivers R.1155 were originally issued with the valve positions marked with trade nomenclatures. Later issues of the receivers are marked with the standard numbers as indicated in col. 3 of the table in para. 116. To remove the difficulty arising when it is necessary to fit spare valves marked in one system into a receiver marked in the other system a valve identification label (Stores Ref. 10D/580) has been prepared. The sequence of operations for affixing the valve label is as follows:—

- (i) Remove the receiver from its case.
- (ii) Identify the flat screening box immediately behind the front panel and adjacent to the tuning condensers.
- (iii) Use shellac varnish (Stores Ref. 33A/511) to fix the valve identification label on to the top screening plate so that it can be read from the front of the instrument, and so that it does not cover either the remaining four screws or the ventilation hole.
- (iv) Apply a thin coat of shellac varnish over the label.
- (v) Replace the receiver in its case.

Valve replacements

118. Certain valves, supplied as spares for this receiver, are too large in diameter to go into the screening cans as originally supplied. To overcome this difficulty the cans are now being manufactured without the longitudinal stiffening ribs. Where, however, it is found that the original cans remain, Units are to remove the ribs on all valve screening cans so that in the event of oversize valves being issued the cans may be ready to accommodate them. The method to be adopted is to remove the can from the receiver and, placing it on a round bar or pipe of suitable diameter, gently beat out the ribs from the outside. Should renewal of the valve V_4 be necessary, or should it be exchanged when pairing V_1 and V_2 (see para. 51) care must be taken that no valve having a metallised envelope is placed in the V_4 socket. The socket for the pin connected to the valve metallising is used to anchor a H.T. line, and the insertion of a metallised valve would short the H.T. supply via the earthed screen of the grid lead.

Removal of B.F.O. valve

119. Due to restricted space in early issues of the receiver, difficulty may be experienced in removing the B.F.O. valve V_7 without altering the adjustment of the B.F.O. tuning condenser C_{13} . Originally this condenser was a type 900 but this has been replaced in later models by a type 1525 and no difficulty will be experienced in removing, or inserting, the valve V_7 where this replacement has been made. The procedure to be followed when removing V_7 is as follows:—

- (i) Remove the receiver from its outer case.
- (ii) Remove the top cover of the oscillator unit, type 18, by withdrawing the six screws securing it. The valve V_7 and condenser, type 900, C_{13} , will now be exposed.
- (iii) Using a suitable screwdriver, rotate the condenser, type 900, until the moving vanes are fully engaged with the fixed vanes. The valve can now be readily removed and replaced without fouling the condenser.
- (iv) Replace the top cover of the oscillator unit and place the receiver in its outer case.
- (v) Set up the B.F.O. as described in para. 93.

Prevention of frequency drift

120. Cases have occurred of excessive frequency drift in the beat frequency oscillator. This has been traced to (i) the overheating of the fixed silver-mica condensers in the B.F.O. compartment, causing alteration of capacitance and (ii) the presence of sulphur from the sorbo pad used to prevent the valve V_7 from touching the lid. The modification consists of drilling a ventilation hole in the B.F.O. compartment lid together with renewal, if necessary, of the valve identification label. The procedure is as follows:—

- (i) Withdraw the receiver from its case.
- (ii) Remove the lid of the B.F.O. compartment situated immediately behind the front panel by withdrawing the six securing screws.
- (iii) Remove the sorbo pad from the inside of the lid.
- (iv) Cut a hole $1\frac{1}{2}$ in. dia. in the B.F.O. compartment lid, the centre of the hole being directly above the valve top cap, that is, approximately 1 in. from the long edge and $1\frac{1}{8}$ in. from the short edge of the lid.
- (v) Refit and secure the lid to the compartment.

- (vi) Readjust, if necessary, the frequency of the trimmers as described in para. 165.
- (vii) If the operation (iv) above has damaged the valve identification label, use shellac varnish to fix a new label to the rear inside face of the receiver case in the most suitable position for reading, or in the position described in para. 117 (iii).
- (viii) Apply a thin coat of shellac varnish over the label.
- (ix) Replace the receiver in its case.

Alignment of incorrectly calibrated receivers

121. A number of receivers of versions other than L and N were incorrectly calibrated at the high frequency end of the scale. Arrangements were made for these to be realigned in accordance with leaflet A.P.1186/B.68 dated 8/7/43. Receivers which have been examined for this defect will bear a label stating either "Calibration checked in accordance with A.P.1186/B.68 dated 8/7/43" or "Recalibrated in accordance with A.P.1186/B.68 dated 8/7/43".

122. Where any doubt exists as to the accuracy of calibration of a receiver not bearing one of the labels mentioned, the receiver calibration should be checked against a wavemeter W.1191 (Stores Ref. 10T/31), or W.1191A, if available, and re-calibrated when the errors are greater than those shown below:—

Range	Error
1 (18.5 Mc/s–7.5 Mc/s)	± 100 kc/s
2 (7.5 Mc/s–3.0 Mc/s)	± 50 kc/s
3 (1500 kc/s–600 kc/s)	± 6 kc/s
4 (500 kc/s–200 kc/s)	± 3 kc/s
5 (200 kc/s– 75 kc/s)	± 1.5 kc/s

If recalibration is not necessary affix a label with the inscription "Calibration checked in accordance with A.P.2548A, Vol. I, Chap. 2, para. 122" to the case in a prominent position.

123. The instructions detailed in para. 122 are on no account to be applied when the calibration is incorrect over the entire scale on one or more ranges, or is wrong at the low frequency end only.

124. The following table gives a comparison of the numbering of the trimmers. Reference is made to figs. 3, 3A, and 17 and to the numbering on the cover of the trimmers in the receiver.

R.F. Oscillator trimmers (first group of five)						
Figs. 3, 3A, and 17	...	C ₆₉	C ₇₀	C ₆₈	C ₇₁	C ₇₂
Receiver Range No....	...	4	3	5	2	1
2nd R.F. trimmers (second group of five)						
Figs. 3, 3A, and 17	...	C ₆₃	C ₆₄	C ₆₅	C ₆₆	C ₆₇
Receiver Range No....	...	4	3	2	5	1
1st R.F. trimmers (third group of five)						
Figs. 3, 3A, and 17	...	C ₅₉	C ₆₀	C ₆₁	C ₅₈	C ₅₇
Receiver Range No....	...	3	2	1	4	5

125. The following is the sequence of operations:—

- (i) Withdraw the receiver from its case and connect the power supplies.
- (ii) Set receiver master switch to OMNI and volume control to maximum.
- (iii) Put receiver range switch to range 1.
- (iv) Set the wavemeter to 16 Mc/s.
- (v) Set the receiver tuning pointer to 16 Mc/s.
- (vi) Adjust trimmer osc.1 (C₇₂) for loudest signal. (Reduce volume if necessary during this operation.)

Note.—In most of these operations it will be found necessary to turn the trimmer in a counter-clockwise direction.

- (vii) Decrease volume until signal is very weak and adjust 2ND RF 1 (C₆₆) for loudest signal.
- (viii) Again decrease volume control and adjust 1ST RF 1 (C₆₁) for loudest signal.
- (ix) (a) Adjust wavemeter to 7 Mc/s.
(b) Receiver to range 2.

- (c) Tuning pointer to 7 Mc/s.
- (d) Volume control.
- (x) Repeat tuning operations as in (vi), (vii), and (viii) above for:—
 osc. 2 (C₇₁) 2ND RF 2 (C₈₈) 1ST RF 2 (C₈₀)
- (xi) Repeat similarly, using the appropriate trimmers (para. 124) for ranges 3, 4, and 5 and the frequencies:—
- | | | | | | |
|---------|-----|-----|-----|-----|-----------|
| Range 3 | ... | ... | ... | ... | 1430 kc/s |
| Range 4 | ... | ... | ... | ... | 500 kc/s |
| Range 5 | ... | ... | ... | ... | 185 kc/s |
- (xii) Seal trimmers with bakelite varnish. Care should be taken to ensure that sealing material does not penetrate between the trimmer nut and metal washer, or between the ceramic spacer and condenser plate. The sealing material should be smeared only on top of the trimmer nut and that part of the trimmer screw which emerges from the nut. *Adjustment in service is only permissible of those trimmers referred to above.*
- (xiii) Replace the receiver chassis in its case.
- (xiv) Affix a label prominently to the case bearing the inscription:—"Recalibrated in accordance with A.P.2548A, Vol. I, Chap. 2, para. 125". Cover the label with clear varnish.

Periodic inspections

126. In addition to the inspections called for in the aircraft inspection schedule, i.e. Vol. II, Part 2 of the appropriate aircraft Air Publication, the following items must be attended to at the intervals shown. The receiver and transmitter will normally be serviced at the same time. The transmitter inspections are given in Chap. 1 of this publication.

Minor inspections

- (i) Remove all deposits of carbon and copper dust from the commutators and brush-gear of the power unit by dry air blast. Examine the commutators for scoring and clean as necessary with carbon tetrachloride.
- (ii) Lubricate the bearings of the power unit with two drops of oil (Stores Ref. 34A/60) for each bearing.
- (iii) Check the starting relay for correct operation. Adjust the relay contacts as necessary.
- (iv) Test all valves in the valve tester.
- (v) Examine control knobs, dial, and switches for slackness.
- (vi) Check the calibration of the receiver tuning scale for accuracy. Ensure that the noise level is not abnormal, the volume control operates smoothly and that the tuning indicator functions correctly.

"One star" inspections

- (vii) Remove the L.T. power unit from the aircraft for overhaul and operational check on the test bench as follows:—
 - (a) Examine the rotary transformer bearings for excessive wear and for lack of lubrication.
 - (b) Examine the brushes for excessive wear and check for freedom of movement. Ensure that the brushes bed correctly on the commutators.
 - (c) Check the brush springs for correct tension.

Note.—Do not disturb the seating of the brushes unnecessarily otherwise bad contact may result.

This leaf issued in reprint
September, 1947

A.P.2548A, Vol. I, Chap. 2

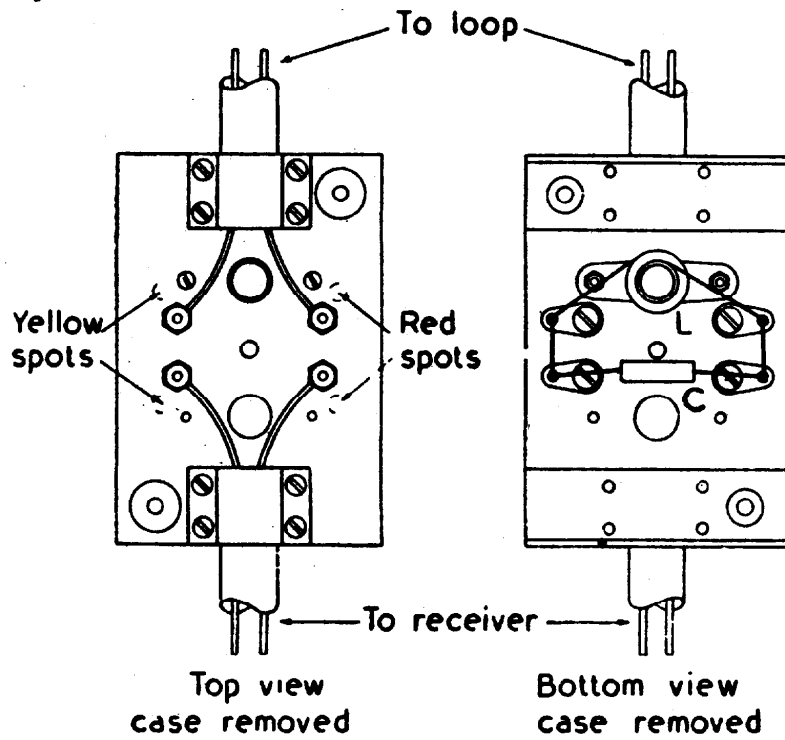

TYPE 12

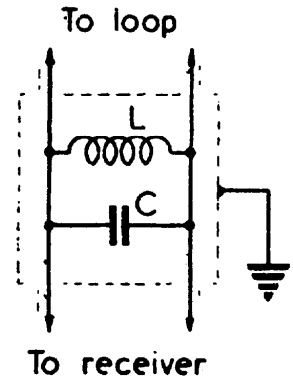

TYPE 12	
C	40 μF
L	410 μH

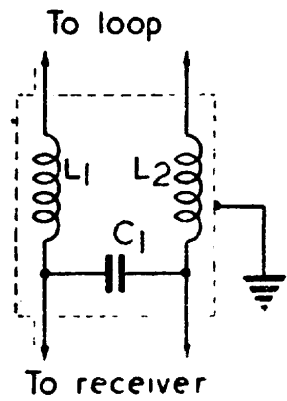
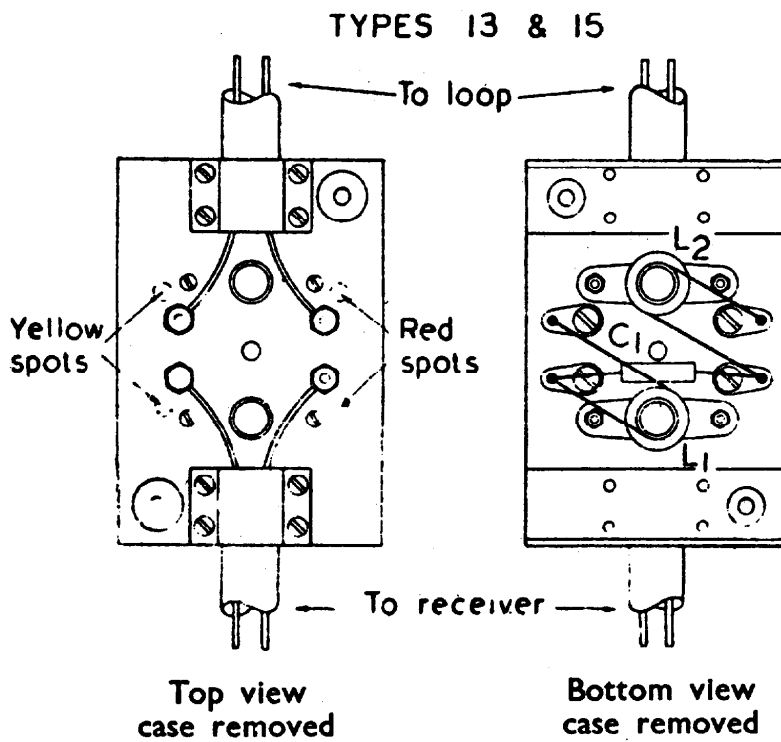

TYPE 13	
C ₁	70 μF
L ₁	20 μH
L ₂	20 μH
TYPE 15	
C ₁	70 μF
L ₁	8 25 μH
L ₂	8 25 μH

FIG. 24.—THE IMPEDANCE MATCHING UNITS, TYPES 12, 13, AND 15

APPENDIX 1

ASSOCIATED EQUIPMENT

The impedance matching units, types 12, 13, and 15

1. The R.1155 is designed for use with the D.F. loop aerial, type 3, which has an inductance value of approximately $100\mu\text{H}$ and a self-capacitance of $20\mu\mu\text{F}$. Should the inductance placed across the loop terminals differ appreciably from this value, the input tuned circuit will not gang correctly with the other tuned circuits. As the receiver is required for use with loop aerials of widely differing values of inductance from the type 3, a matching unit is necessary with these loops. The impedance matching units, type 12 (Stores Ref. 10A/12148), type 13 (Stores Ref. 10A/12245) and type 15 (Stores Ref. 10A/12247) have been designed for application as indicated in para. 73. The matching unit consists of a small metal box containing a panel of bakelized linen carrying four terminals to which are connected the Duradio No. 20 screened cables from the loop and to the receiver. The matching coils and condensers are also mounted on this panel. The unit weighs about 12 oz.

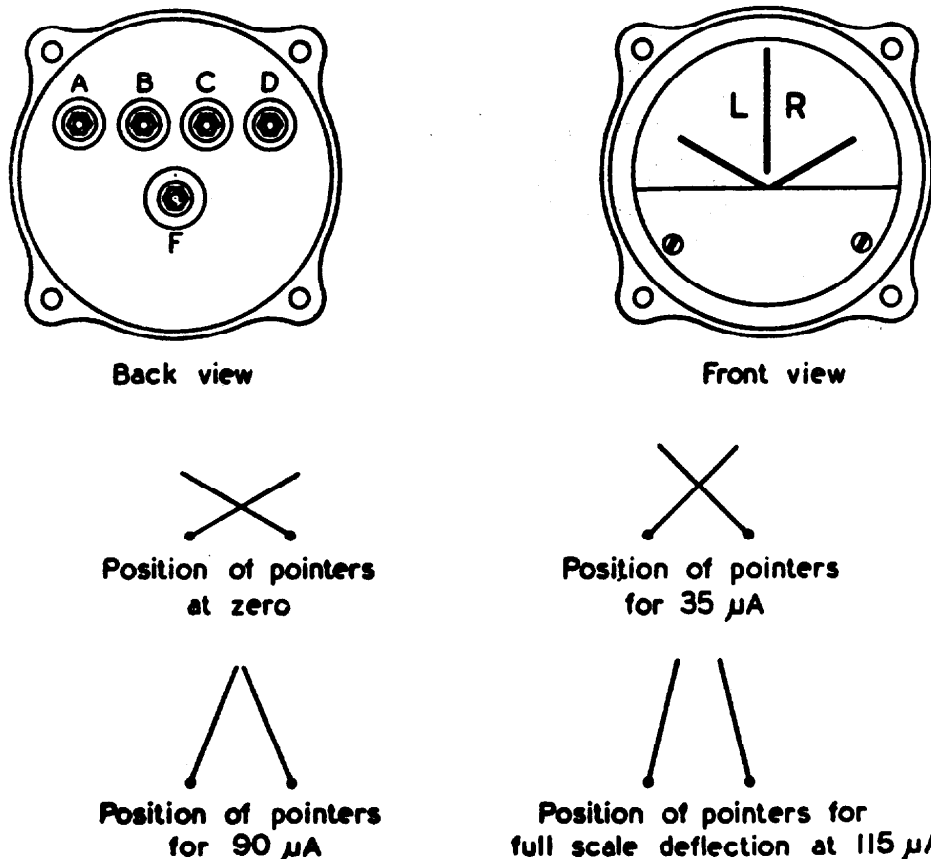

FIG. 25.—VISUAL INDICATOR, TYPE 1

2. The theoretical circuits and constructional details of the matching units are shown in fig. 24. The matching unit circuit depends upon whether it is required to reduce the inductance of the loop or to increase it. If a reduction in value is required a shunt unit (type 12) is used. This consists of one matching coil L with a condenser C both in shunt across the twin leads of the loop. If an increase in value is necessary the series units (types 13 and 15) are used. To preserve the symmetry of the loop two series coils L_1 and L_2 , of equal inductance, are connected, one to each lead from the loop to the receiver. A condenser C_1 is connected in shunt across the receiver leads. The condenser brings the total capacitance of the circuit to the correct value.

3. The unit condenser C, type 12, has a capacitance of $40 \mu\mu\text{F}$ and the coil L consists of 150 turns of 38 d.s.c. wire on a former and is adjusted by a dust-iron screwed core to $410 \mu\text{H}$. The unit condenser C_1 , type 13, is $70 \mu\mu\text{F}$ and the coils L_1 and L_2 each consist of 29 turns of 30/48 litz wire adjusted to $20 \mu\text{H}$. The corresponding values for components of the unit, type 15, are $70 \mu\mu\text{F}$ and $8.25 \mu\text{H}$. The four terminals are colour-coded by indicator spots of red and yellow and it is essential that due regard should be paid to these when fixing the cable ends.

The visual indicator, type 1

4. The visual indicator, type 1 (Stores Ref. 10Q/2) consists essentially of two D.C. milliammeter movements mounted side by side. The windings, which are connected in series, each have a resistance of 500 ohms. The current sources applied to opposite ends of the conjoint winding produce deflection of a heavily damped indicator needle in opposite sense. The intersection of the indicator needles follows a straight line between zero and 90 microamps current. Approximately 2.4 microamps are required to produce one degree scale deflection. The visual indicator is shown in fig. 25.

5. The visual indicator is contained in a circular metal screening case of, approximately, $3\frac{1}{2}$ in. diameter. The depth of the casing may vary in different models but the overall maximum depth is $3\frac{1}{4}$ in. The instrument weighs 1 lb. 7 oz. Its general appearance is shown in the drawings of fig. 25 and a theoretical circuit forms part of fig. 13.

6. The indicator is fixed in position through four fixing lugs of 0.187 in. dia. and a space of 4.12 in. dia. by 4 in. deep should be allowed behind the panel for an anti-vibrational mounting. Five terminals, nominated A, B, C, D, and F, are mounted on the rear of the indicator. The terminal F is a binding post for securing the cable. The connections of terminals A, B, C, and D differ according to the number of indicators installed. The normal connections are shown in the installation diagram of fig. 21.

7. The mounting, type 119 (Stores Ref. 10A/12954) has been introduced for use with the visual indicator. The lampholder, type 61 (Stores Ref. 10A/13078), lamp, filament, 12 volts, jack type, G.P.O. No. 3 (Stores Ref. 5L/1150) or lamp, filament, 24 volts, jack type, G.P.O. No. 3 (Stores Ref. 5L/1898) are also used when required. The equipment required and the installation procedure are detailed in para. 78 and is the subject of leaflet A.P.1186/E85.

APPENDIX 2

LIST OF PRINCIPAL COMPONENTS

The following list of parts is issued for information only. When ordering spares A.P.1086 must be consulted.

CONDENSERS

Circuit Ref.	Capacity	Type	Stores Ref. No.	Remarks
$C_1 + C_{92} + C_{94}$	$2.5 \mu\text{F} + 2.5 \mu\text{F} + 1.0 \mu\text{F}$	892	10C/960	Pre-set 2 of 800 $\mu\mu\text{F}$ in parallel
$C_2 + C_{93}$	$(0.1 \mu\text{F} + 0.1 \mu\text{F}) + 0.1 \mu\text{F}$	1,662	10C/3399	
$C_3 + C_4 + C_5$	$2.5 \mu\text{F} + 1.0 \mu\text{F} + 2.5 \mu\text{F}$	894	10C/962	
C_6	100 $\mu\mu\text{F}$	895	10C/963	
C_7	0.005 μF	2,900	10C/5352	
C_8, C_9	0.001 μF	2,195	10C/4250	
C_{10}	0.004 μF	3,376	10C/11140	
C_{11}	100 $\mu\mu\text{F}$	895	10C/963	
C_{12}	0.1 μF	899	10C/967	
C_{13}	5 to 60 $\mu\mu\text{F}$ var.	1,525	10C/3129	
C_{14}	1,600 $\mu\mu\text{F}$	901	10C/969	
C_{15}	4,550 $\mu\mu\text{F}$	917	10C/2005	
C_{16}	0.5 μF	902	10C/970	
C_{17}	100 $\mu\mu\text{F}$	918	10C/2006	
C_{18}	0.005 μF	2,900	10C/5352	
C_{19}	0.001 μF	4,356	10C/13364	
$C_{20} \text{ to } C_{24}$	0.005 μF	2,900	10C/5352	
C_{25}	0.001 μF	4,356	10C/13364	
$C_{26} + C_{27} + C_{28}$	$0.1 \mu\text{F} + 0.1 \mu\text{F} + 0.1 \mu\text{F}$	1,662	10C/3399	
$C_{29} + C_{30} + C_{31}$	$0.1 \mu\text{F} + 0.1 \mu\text{F} + 0.1 \mu\text{F}$	1,662	10C/3399	
$C_{32} + C_{33} + C_{34}$	$0.1 \mu\text{F} + 0.1 \mu\text{F} + 0.1 \mu\text{F}$	1,662	10C/3399	
C_{35}	0.1 μF	899	10C/967	
C_{36}	200 $\mu\mu\text{F}$	904	10C/972	
C_{37}, C_{38}	0.1 μF	899	10C/967	See C_{26}
C_{39}	—	—	—	See C_7
C_{40}	0.1 μF	899	10C/967	
$C_{41} + C_{42} + C_{50}$	$0.1 \mu\text{F} + 0.1 \mu\text{F} + 0.1 \mu\text{F}$	1,662	10C/3399	
C_{43}, C_{44}	25 $\mu\mu\text{F}$	919	10C/2007	
C_{45}, C_{46}	240 $\mu\mu\text{F}$	920	10C/2008	
C_{47}, C_{48}	80 $\mu\mu\text{F}$	921	10C/2009	
C_{49}, C_{51}	200 $\mu\mu\text{F}$	3,556	10C/11658	
$C_{52} + C_{53} + C_{54}$	$0.1 \mu\text{F} + 0.1 \mu\text{F} + 0.1 \mu\text{F}$	1,662	10C/3399	See C_{41}
C_{55}	0.05 μF	3,361	10C/11125	
C_{56}	0.5 μF	902	10C/970	
C_{57}	8-105 $\mu\mu\text{F}$ var.	1,665	10C/3402	
$C_{57} \text{ to } C_{61}$	5 x 4 to 40 $\mu\mu\text{F}$ var.	—	10C/3173	Condenser unit, type 34
$C_{62} \text{ to } C_{64}$	5 x 4 to $\mu\mu\text{F}$ 40 var.	—	10C/3173	Condenser unit, type 34
C_{67}	0.002 μF	923	10C/2011	
$C_{68} \text{ to } C_{70}$	3 x 4 to 40 $\mu\mu\text{F}$ var.	—	10C/3174	Condenser unit, type 35
C_{71}, C_{72}	5 to 60 $\mu\mu\text{F}$ var.	908	10C/976	
C_{73}	93 $\mu\mu\text{F}$	2,205	10C/4260	
C_{74}	255 $\mu\mu\text{F}$	925	10C/2013	
C_{75}	537 $\mu\mu\text{F}$	926	10C/2014	
C_{76}	1,670 $\mu\mu\text{F}$	927	10C/2015	
C_{77}	6,170 $\mu\mu\text{F}$	928	10C/2016	
C_{78}	20 $\mu\mu\text{F}$	429	10C/10948	
C_{79}	15 $\mu\mu\text{F}$	910	10C/978	
C_{80}	25 $\mu\mu\text{F}$	1,439	10C/3027	
C_{81}	15 $\mu\mu\text{F}$	910	10C/978	
$C_{82} + C_{83} + C_{84}$	—	4,597 or 1,440	10C/13984 10C/3028	Variable 3-gang, with scale to suit R.1155L and N only Other versions

CONDENSERS—Contd.

Circuit Ref.	Capacity	Type	Stores Ref. No.	Remarks
C_{91} to C_{93}	300 $\mu\mu\text{F}$	929	10C/2017	
C_{93}	600 $\mu\mu\text{F}$	903	10C/971	
C_{95}	300 $\mu\mu\text{F}$	929	10C/2017	
C_{91}	40 $\mu\mu\text{F}$	4,688	10C/14211	
C_{92}	—	—	—	See C_1
C_{93}	4 μF	911	10C/979	
C_{94}	—	—	—	See C_1
C_{95}	0.5 μF	902	10C/970	
C_{96}	0.02 μF	3,360	10C/11124	
C_{97}, C_{98}	2.2 $\mu\mu\text{F}$ or 2 $\mu\mu\text{F}$	4,939 or 913	10C/14719 10C/2001	
C_{99}	100 $\mu\mu\text{F}$	918	10C/2006	
C_{100}	200 $\mu\mu\text{F}$	3,556	10C/11658	
C_{101}	4 $\mu\mu\text{F}$ or 3.9 $\mu\mu\text{F}$	914 or 4,955	10C/2002 10C/14757	
C_{102}	0.001 μF	4,356	10C/13364	
C_{103}	0.005 μF	2,900	10C/5352	
C_{104}	75 $\mu\mu\text{F}$ var.	900	10C/968	In plug, type 209
C_{105}	0.1 μF	3,362	10C/11126	
C_{106}	65 $\mu\mu\text{F}$	1,265	10C/2649	In plug, type 209
C_{107}	0.1 μF	3,381	10C/11157	
C_{108}	200 $\mu\mu\text{F}$	904	10C/972	
C_{109}	100 $\mu\mu\text{F}$	2,685 or 611	10C/4995 10C/96	} Preferred
C_{110}	40 $\mu\mu\text{F}$	4,688	10C/14211	
C_{111}	8 $\mu\mu\text{F}$	1,729	10C/3503	
C_{112}	30 $\mu\mu\text{F}$	2,612	10C/4922	
C_{112}, C_{111}	160 $\mu\mu\text{F}$	2,613	10C/4923	
C_{113}	300 $\mu\mu\text{F}$	1,474	10C/3064	
C_{116}	1,320 $\mu\mu\text{F}$	925	10C/2013	R.1155L and N

RESISTORS

Circuit Ref.	Resistance in ohms	Type	Stores Ref. No.	Remarks
R_1	2,000	1,001	10W/1001	4,700 ohms in some receivers
R_2, R_3	1,200	1,002	10W/1002	
R_4	120	1,003	10W/1003	
R_5	1,000	500	10W/11667	
R_6	1,500	592	10W/124	
R_7	270	860	10W/860	
$R_{8(1)}$	50,000	1,000	10W/1000	Dual potentiometer
$R_{8(2)}$	500,000			
R_9	2,000,000	1,004	10W/1004	
R_{10}, R_{11}	150,000	478	10W/11382	
R_{12}	27,000	1,005	10W/1005	
R_{13}	1,000,000	480	10W/11384	
R_{14}	1,000	500	10W/11667	
R_{15}	30,000	1,007	10W/1007	
R_{16}	27,000	1,006	10W/1006	
R_{17}	1,500	1,082	10W/1082	
R_{18}	10,000	906	10W/777	
R_{19}, R_{20}	56,000	1,008	10W/1008	
R_{21}	470,000	989	10W/989	
R_{22}	1,000	500	10W/11667	
R_{23}	20,000	998	10W/998	Variable 6,000 to 20,000 ohms or may be resistance unit 10W/12616 (14,000 ohms vari- able plus 6,000 ohms in series) in some receivers
R_{24}, R_{25}	22,000	1,010	10W/1010	
R_{26}	100,000	993	10W/993	
R_{27}	27,000	1,006	10W/1006	
R_{28}	22,000	1,010	10W/1010	
R_{29}	100,000	993	10W/993	
R_{30}	2,200	875	10W/691	
R_{31}	27,000	1,006	10W/1006	

RESISTORS—Contd.

Circuit Ref.	Resistance in ohms	Type	Stores Ref. No.	Remarks
R ₃₂	22,000	1,010	10W/1010	
R ₃₃	100,000	993	10W/993	
R ₃₄	2,200	875	10W/691	
R ₃₅	22,000	1,278	10W/1278	
R ₃₆	27,000	1,006	10W/1006	
R ₃₇	22,000	1,010	10W/1010	
R ₃₈	100,000	993	10W/993	
R ₃₉	56,000	1,008	10W/1008	
R ₄₀ , R ₄₁	1,500	1,082	10W/1082	
R ₄₂	2,200	875	10W/691	
R ₄₃	27,000	1,006	10W/1006	
R ₄₄	22,000	1,010	10W/1010	
R ₄₅	100,000	993	10W/993	
R ₄₆	1,500	1,082	10W/1082	
R ₄₇	27,000	1,006	10W/1006	
R ₄₈	3,300	1,464	10W/1464	6,800 ohms in some receivers
R ₄₉	27,000	1,006	10W/1006	
R ₅₀	3,300	1,464	10W/1464	6,800 ohms in some receivers
R ₅₁	20,000	999	10W/999	Variable
R ₅₂	6,800	991	10W/991	
R ₅₃	560,000	992	10W/992	
R ₅₄ , R ₅₅	56,000	1,008	10W/1008	
R ₅₆	240	995	10W/995	
R ₅₇	560,000	992	10W/992	
R ₅₈	2,200	875	10W/691	
R ₅₉ , R ₆₀	220,000	855	10W/648	
R ₆₁	1,200	6,492	10W/6492	
R ₆₂ , R ₆₃	2,200	996	10W/996	
R ₆₄	200 or 100	1,634 918	10W/1634 10W/2006	R ₆₄ is 100 ohms when R ₆₃ is fitted
R ₆₅ , R ₆₆	10,000	505	10W/11671	
R ₆₇	22,000	1,010	10W/1010	
R ₆₈	56,000	1,008	10W/1008	Not always fitted
R ₆₉	100	918	10W/2006	
R ₇₀	1,000	500	10W/11667	
R ₇₁	150,000	7,373	10W/7373	
R ₇₂	68	8,076	10W/8076	
R ₇₃	470	2,760	10W/9507	R.1155L and N
R ₇₄	150	1,931	10W/1931	R.1155L and N

OTHER COMPONENTS

Circuit Ref.	Nomenclature	Stores Ref. No.	Remarks
COILS, CHOKES, etc.			
L ₁	Coil, Dummy Loop	10D/1644	
L ₂	Coil, Aerial, Range 1	10D/1643	
L ₃	Coil, Aerial, Range 2	10D/955	
L ₄	Coil, D.F., Range 3	10D/161	
L ₅	Coil, D.F., Range 4	10D/162	
L ₆	Coil, D.F., Range 5	10D/163	
L ₇	Coil, Anode, Range 1	10D/1635	
L ₈	Coil, Anode, Range 2	10D/1636	
L ₉	Coil, Anode, Range 3	10D/1637	
L ₁₀	Coil, Anode, Range 4	10D/1638	
L ₁₁	Coil, Anode, Range 5	10D/953	
L ₁₂	Coil, Filter, I.F.	10D/957	
L ₁₃	Coil, Oscillator, Range 1	10D/958	
L ₁₄	Coil, Oscillator, Range 2	10D/1639	
L ₁₅	Coil, Oscillator, Range 3	10D/1640	
L ₁₆	Coil, Oscillator, Range 4	10D/1641	
L ₁₇	Coil, Oscillator, Range 5	10D/1642	

OTHER COMPONENTS—Contd.

Circuit Ref.	Nomenclature	Stores Ref. No.	Remarks
L ₁₈	Coil, Oscillator Choke, Ranges 1 and 2	10D/1645	
L ₁₉	Transformer, Type 130	10K/12136	1st I.F.
L ₂₀	Transformer, Type 366	10K/251	2nd I.F.
L ₂₁	Transformer, Type 131	10K/12137	3rd I.F.
L ₂₂	Inductance, Type 507	10C/5920	
L ₂₃	Transformer, Type 132	10K/12138	
L ₂₄	Choke, H.F., Type 71	10C/583	
L ₂₅	Choke, H.F., Type 94	10C/2186	
L ₂₆	Choke, H.F., Type 83	10C/2019	
L ₂₇	Choke, H.F., Type 83	10C/2019	
L ₂₈	Choke, H.F., Type 83	10C/2019	
L ₂₉	Choke, A.F.	—	
L ₃₀	Transformer, Type 133	10K/12139	
L ₃₁	Filter Unit, Type 46	10P/13007	Unit includes C ₁₁₁
L ₃₂	Inductance, Type 394	10C/4839	Part of Filter Unit, Type 45
L ₃₃	Inductance, Type 393	10C/4838	Part of Filter Unit, Type 71
L ₄₀	Coil, Aerial, Range 2A	10D/2031	R.1155L and N
L ₄₁	Coil, Anode, Range 2A	10D/2032	R.1155L and N
L ₄₂	Coil, Oscillator, Range 2A	10D/2033	R.1155L and N
FILTER UNITS			
HFC ₁	} Filter Unit, Type 66	10P/13046	
HFC ₂			
HFC ₃			
HFC ₄			
HFC ₅			
HFC ₆	Filter Unit, Type 65	10P/13045	
L ₃₂ , C ₁₁₄	Filter Unit, Type 67	10P/13047	
L ₃₁ , C ₁₁₁	Filter Unit, Type 67	10P/13047	
L ₃₃ , C ₁₁₃	Filter Unit, Type 45	10P/13006	Anode rejector
	Filter Unit, Type 46	10P/13007	Anode acceptor
	Filter Unit, Type 76	10P/13058	Grid rejector
SWITCHES			
FS wf, FS wr	Switch, Type 370	10F/156	Aerial wafer
FS xf, FS xr	Switch, Type 371	10F/157	Loop aerial
FS yf, FS yr	Switch, Type 369	10F/155	Anode wafer
FS zf, FS zr	Switch, Type 368	10F/154	Oscillator wafer
M.S.	Switch, Type 234	10F/158	Master switch
S ₁ , S ₄ , S ₅	Switch, Type 152	10F/10338	
S ₂	Switch, Type 235	10F/159	Meter deflection
S ₃	Switch, Type 239	10F/163	Aural sense

CHAPTER 3

TEST SET, TYPE 65

LIST OF CONTENTS

	<i>Para.</i>
Introduction	1
General Description	5
Constructional details	13
Operation	
Communications circuit tests	16
Measurement of noise ratio	20
"Figure-of-eight" sensitivity	21
A.V.C. characteristics	23
Tests for D/F. reception	25
Adjustment of vertical aerial trimmer and check of D/F sense	27
Check for false "on course" indication	28
Check of deflection sensitivity control	30
D/F. sensitivity at slow and fast switching speeds	31
Limiter check	32
Balance control check	33
H.T. interlock check	34
Aural sense check	35
Symmetry and sense of meter deflection	36
H.F. breakthrough in H.T. supply leads	41
Lining up H.F. circuits	43
Nomenclature of parts	Appendix I

LIST OF ILLUSTRATIONS

	<i>Fig.</i>
Test set, type 65	1
Circuit of test set	2
Front panel removed from case, showing components	3
Decibel/Microvolt conversion chart	4

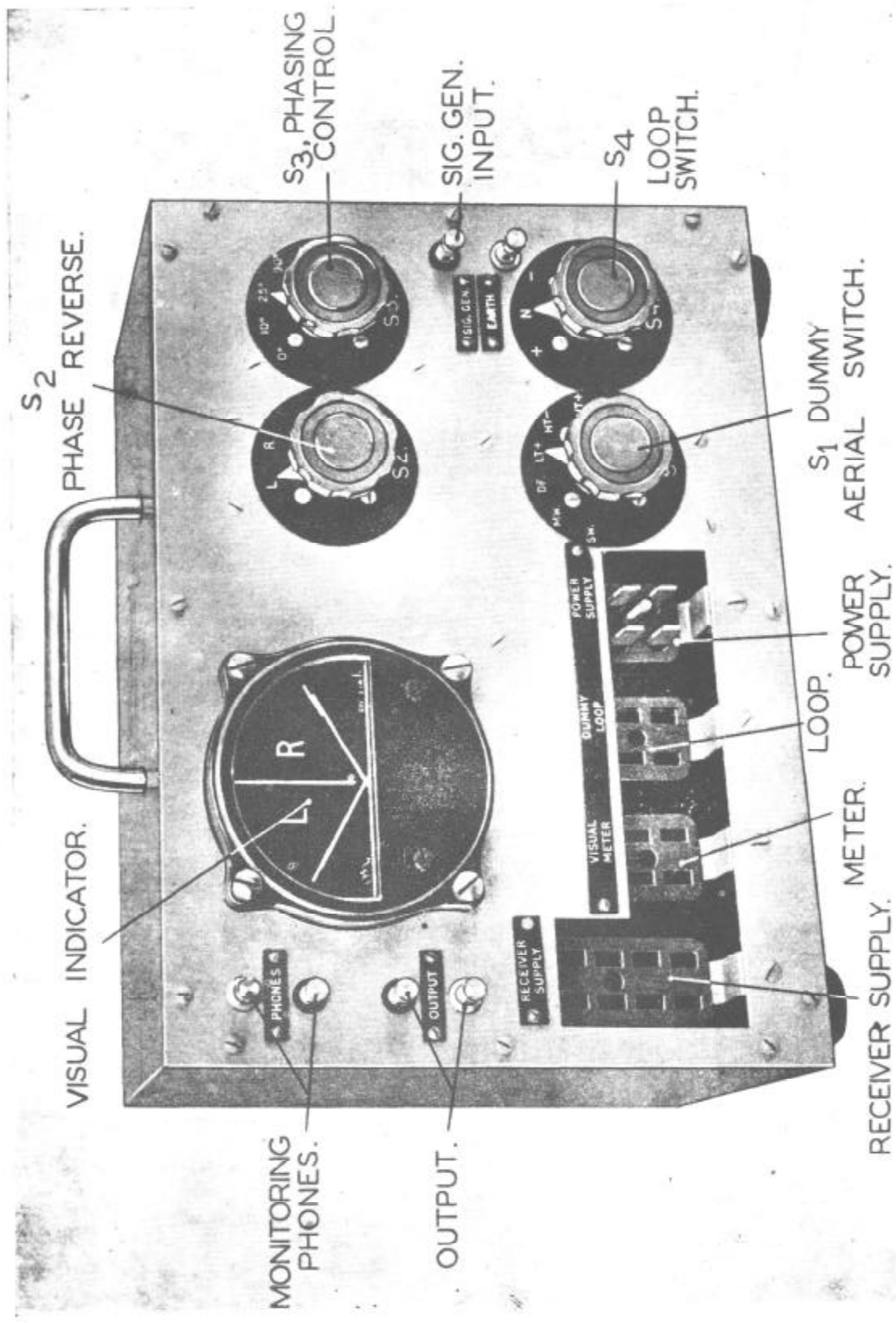

Fig. 1.—Test set, type 65

CHAPTER 3

TEST SET, TYPE 65

(Stores Ref. 10S/137)

Introduction

1. The test set, type 65, is designed for testing the communication and direction-finding performance of receivers R.1155 (see Chapter 2 of this publication). Used in conjunction with a signal generator, it provides simulation of actual working conditions of communication and D/F reception. The output from the signal generator and the power supplies for the receiver are both connected to the test set, whence they reach the receiver main input socket over a common connector. Audio signals from the receiver are returned to the test set by the same connector and are available at two pairs of terminals, for simultaneous supply to an output meter and a pair of phones.

2. Test signals are normally supplied from a signal generator, type 17 (Stores Ref. 10S/11933), which incorporates a 400 c/s modulator and means for adjusting modulation depth. Output may be measured on an output meter, type 2 (Stores Ref. 10S/11934).

3. Receivers under test should take their power supplies from a stabilised source such as the test set, type 112 (Stores Ref. 10S/512). This provides a stabilised and adjustable H.T. output, together with 6.3 V. a.c. for L.T. Alternatively, L.T. can be taken from accumulators, provision being made in the test set, type 112, for adjustment and measurement of voltage.

4. A general view of a test set, type 65, is given in fig. 1. It will be seen that all controls and connections are on the front panel. The visual indicator is a visual indicator, type 1 (Stores Ref. 10Q/2) as used with receivers R.1155 in aircraft installations.

GENERAL DESCRIPTION

5. The theoretical circuit of the test set is given in fig. 2. A1 and A2 are dummy aerials consisting of pure capacitances of 140 and 425 micro-microfarads respectively. The total amount of screened lead between these condensers and the receiver plug must present a further capacitance of 100 micro-microfarads to earth. This is provided in the special leads supplied with the instrument.

6. The dummy loop (D.L.) consists of a primary of 5 turns of 36 gauge D.S.C. wire, wound over a secondary of 90 turns of the same gauge on a $\frac{7}{16}$ in. diameter former with a dust iron core. A 100 $\mu\mu$ F fixed condenser and a 100 $\mu\mu$ F variable condenser are wired in parallel with the secondary. The input coupling coil (I.C.) consists of a 7-turn primary (24 gauge s.w.g.) over which is wound a secondary of 15 turns (36 gauge s.w.g.) also on a dust iron core former. An input correction coil (C.C.) with a 50 $\mu\mu$ F condenser in parallel is wired in series with the secondary of the input coupling coil and the primary of the dummy loop. This coil consists of 20 turns of 28 gauge D.S.C. wire with a dust iron core.

7. Switch S_1 has six positions: s.w., m.w., D.F., L.T.+, H.T.-, and H.T.+. In the first three positions, the switch connects the signal generator to the correct dummy aerial for H.F., M.F. and D/F. working respectively. The three remaining positions concern special tests in connection with the manufacture of the receiver and should be disregarded during use of the instrument for ordinary test purposes.

8. In addition to performing the foregoing functions, switch S_1 is arranged so that in the D.F. position, the H.T.+ supply lead is connected to pin No. 5 of the receiver plug P_1 (i.e. the interlocked H.T. connection). In the s.w. and m.w. positions of the switch, H.T.+ is connected to pin No. 7 of the receiver plug. In the remaining three positions of the switch, H.T.+ is connected both to pin No. 7 and to pin No. 5.

9. Switch S_2 simply reverses the connections from the dummy loop aerial D.L. to the receiver, thus providing a 180-deg. phase change of the dummy loop voltage.

10. Switch S_3 selects three different phasing resistances, R_1 , R_2 , R_3 , and it has an open-circuit or infinite resistance position. These resistances, in conjunction with the input coupling coil (I.C.) provide a network for the injection of the signal generator voltage such that the actual reception condition of the D/F. loop relative to the vertical aerial can be accurately simulated. The open-circuit position of the switch corresponds to the "on-course" or zero signal position of the loop and the remaining three positions of the switch correspond to angles of deviation of approximately 10 deg., 25 deg. and 90 deg. from the "on-course" position.

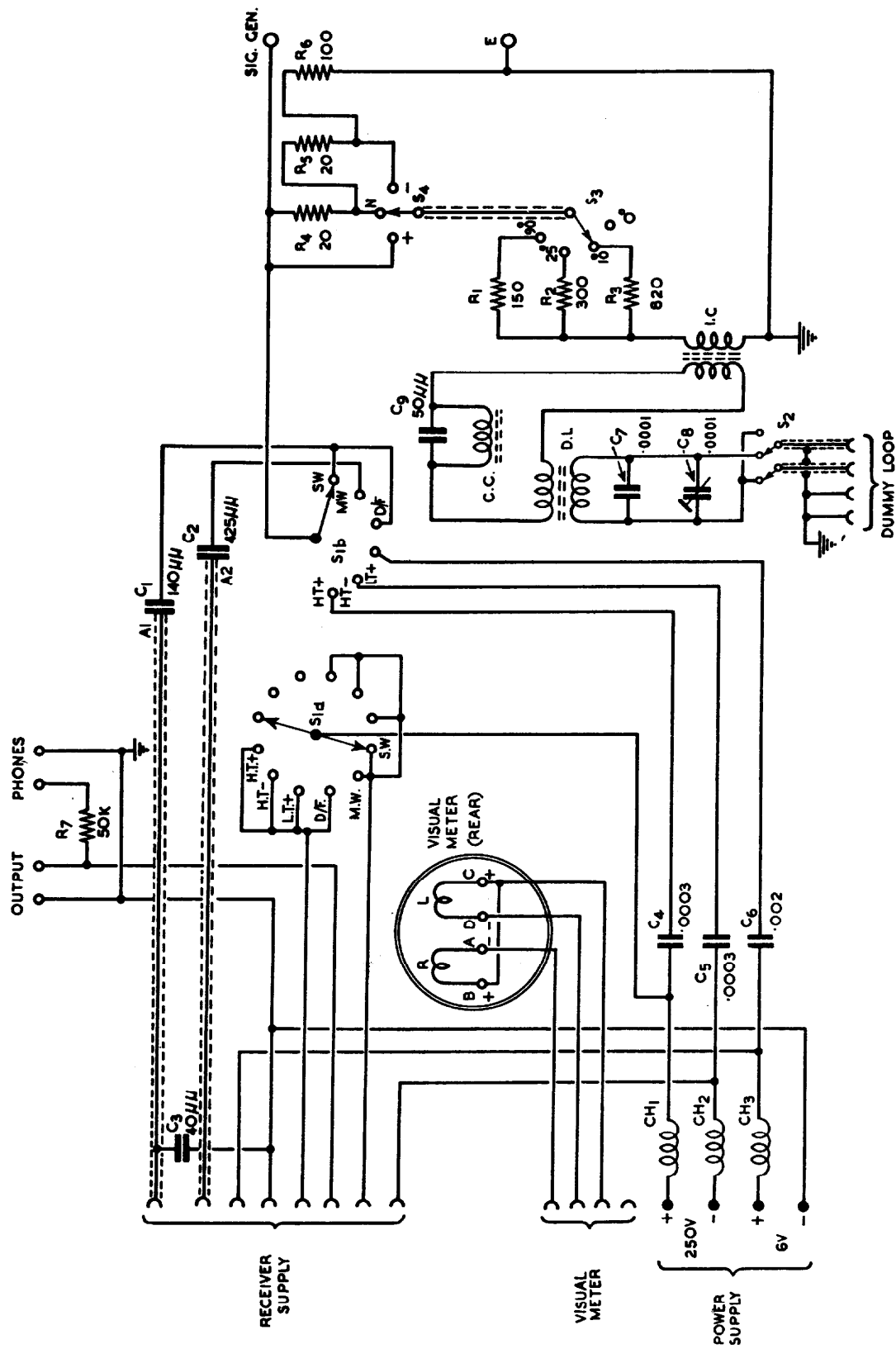

Fig. 2.—Circuit of test set

11. Switch S_4 has three positions, marked N , $+$ and $-$. It provides a slight variation of the ratio of vertical-to-loop aerial voltage, which variations are set to enable the user to determine that the performance of the receiver under test on visual D/F. is within specification limits.

12. The telephone terminals are provided for monitoring purposes and are fed through a 50,000-ohm resistance so that any load placed across them will have a negligible effect on the reading of the output meter which is connected to the output terminals. The output meter load resistance should be 5,000 ohms. The output impedance of the signal generator used should be low and of the order of 10 ohms.

CONSTRUCTIONAL DETAILS

13. The test set is contained in a metal case measuring $10\frac{1}{2}$ in. wide, $7\frac{1}{2}$ in. high, and 5 in. deep. All the components are supported behind the metal front panel, which is secured to the case by twelve screws round the edges. On removal of the screws, the panel and components may be withdrawn intact, as shown in fig. 3.

14. All connections to the instrument are made by means of the sockets, the plug, and the terminals on the front of the panel. The connecting cables supplied are stamped with the same serial number as the test set with which they are issued, and must on no account be interchanged with cables belonging to other instruments of the same type.

15. It will be seen in fig. 2 and 3 that one of the condensers, C_8 , across the dummy loop circuit is of the pre-set type. Adjustment is carried out by the manufacturer and must not be disturbed by users.

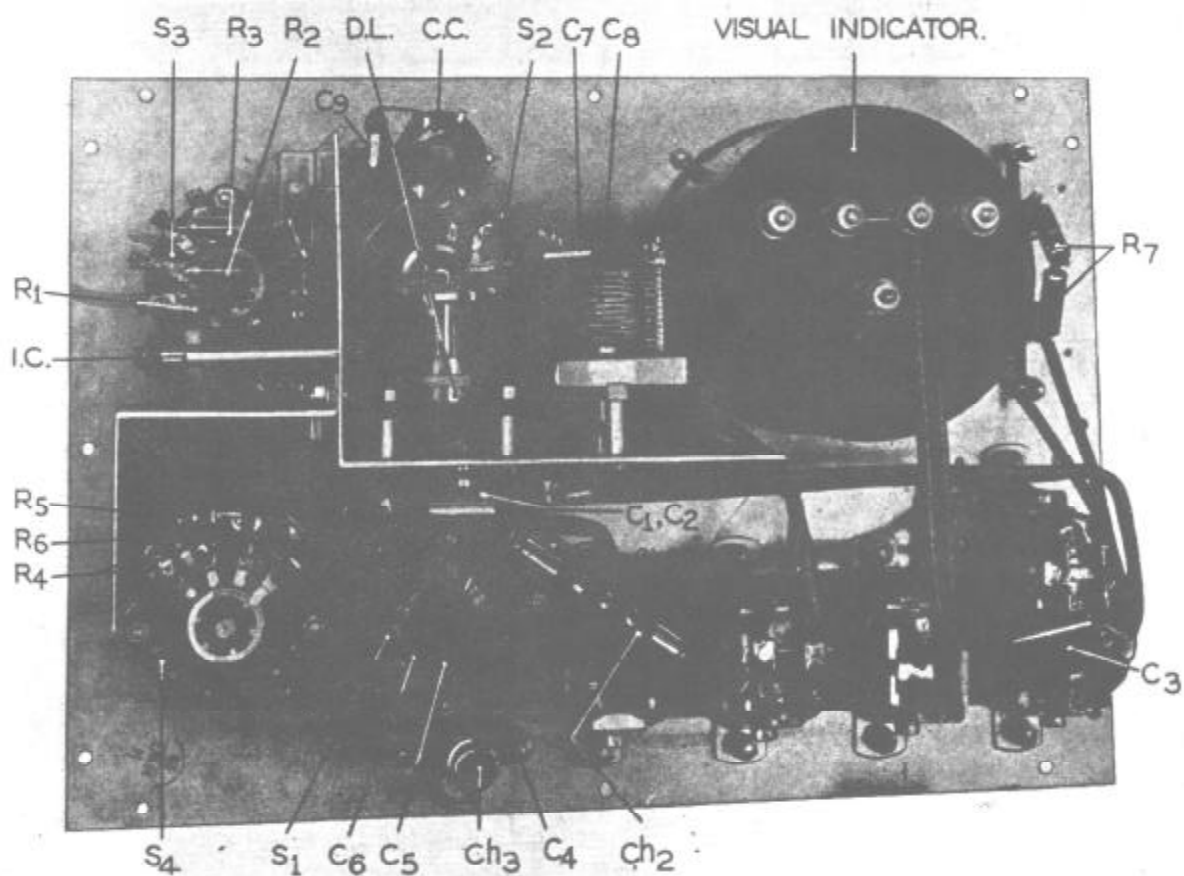

Fig. 3.—Front panel removed from case, showing components

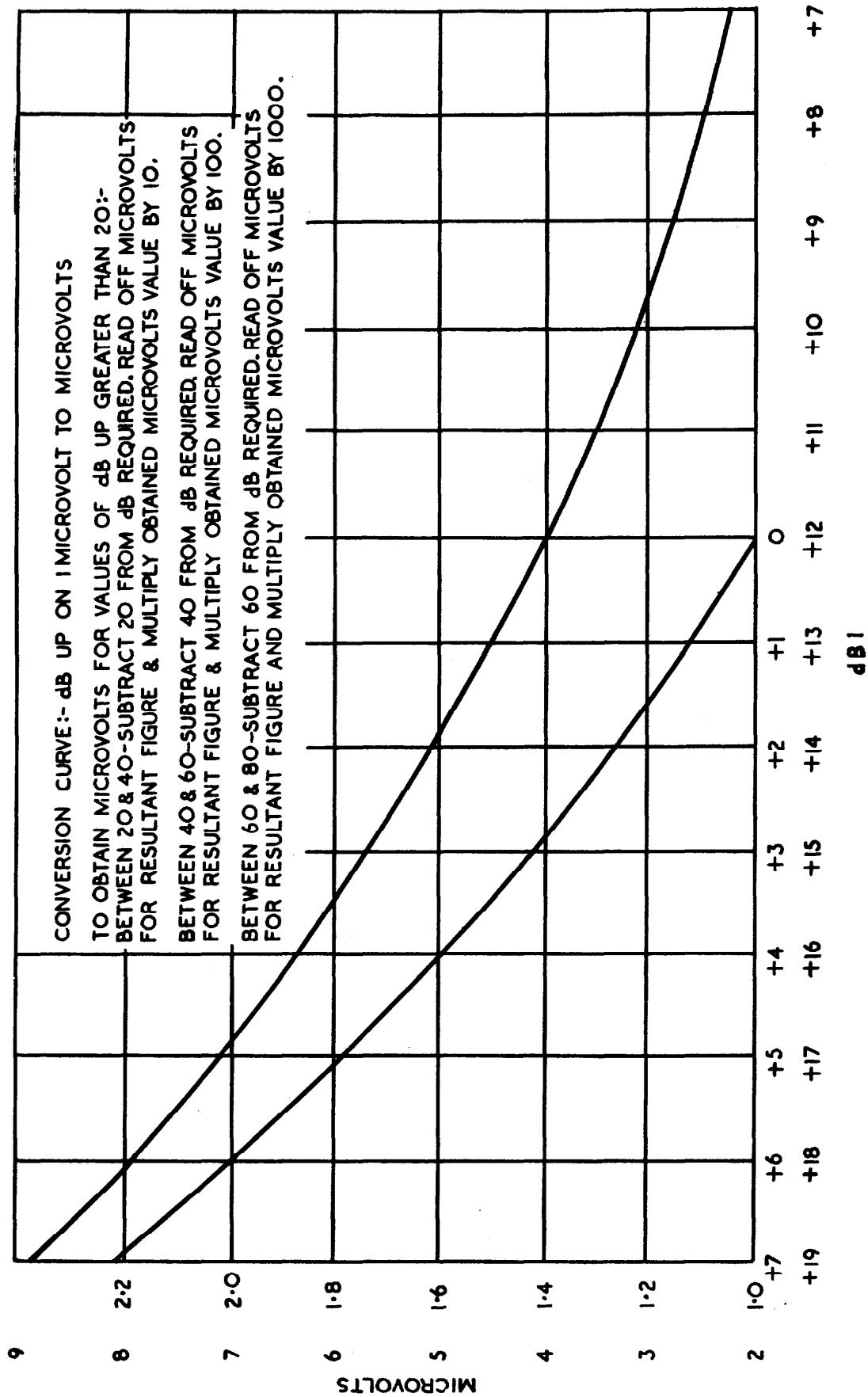

Fig. 4.—Decibel/Microvolt conversion chart

OPERATION

Communications circuit tests

16. Overall sensitivity of receivers is tested by injecting signals of a prescribed level on various frequencies, and observing that the output exceeds 50 mW. into a load of 5,000 ohms, with the receiver volume control at maximum. A suitable output load is provided by the output meter, type 2, the impedance of which can be adjusted to 5,000 ohms.

17. Details of the frequencies covered by the various types of R.1155 receiver on the five positions of the range switch are given in Chapter 2, para. 2.

18. The conditions of the test are to be as follows:—

- Receive master switch at "omni"
- L.F. filter "out"
- Deflection sensitivity switch in "high" position
- Heterodyne switch "off"
- H.T. volts 250 + or - 5 per cent
- L.T. volts 6.3 + or - 5 per cent (supplied from accumulators)
- Test set switch S₁ in the m.w. position for ranges 3, 4, and 5
- Test set switch S₁ in the s.w. position for ranges 1, 2, and 2A
- Test set switch S₂ in the 0-deg. position.

19. It will be seen from Table I that signal generator inputs are expressed in dB up on one microvolt. The graph, fig. 4, enables these figures to be converted into microvolts for setting up signal generator output controls which are not calibrated in decibels.

Measurement of noise ratio

20. On each test frequency the receiver volume control should be adjusted to give a reading of 50 mW. on the output meter. Switch off the signal generator modulation, and observe that the output meter reading is now less than 5.0 mW.

TABLE I
Input frequencies and levels

Frequency	Signal generator input level (dB up on 1 microvolt)	
	R.1155A and E	R.1155B, C, F, L, M, and N
80 kc/s.	36	38
185 " " " " " "	26	27
210 " " " " " "	24	24
500 " " " " " "	17	17
650 " " " " " "	23	24
1430 " " " " " "	22	22
1.55 Mc/s.	—	21
3.3 " " " " " "	25	27
7.0 " " " " " "	11	12
8.0 " " " " " "	27	25
16.0 " " " " " "	20	23

"Figure-of-eight" sensitivity

21. To test the sensitivity of the receiver when set up for aural D/F reception, the receiver master switch is turned to its extreme right-hand position (figure-of-eight), but the other receiver controls remain as shown in para. 18. The test set switch, S₁, must be at D/F, S₂ at 90 DEG., and S₄ at N.

22. Signals of the levels and frequencies shown in Table II are then injected, and at each test the receiver volume control is adjusted to give 0.5 mW. output with the signal generator modulation switched off. With modulation on, the output should exceed 50 mW.

TABLE II
Input frequencies and levels, "figure-of-eight" reception

<i>Frequency</i>	<i>Signal generator input level (dB up on 1 microvolt)</i>	
	<i>R.1155A and E</i>	<i>R.1155B, C, F, L, M and N</i>
80 kc/s.	53	—
90 "	—	56
185 "	52	54
210 "	49	50
500 "	47	48
650 "	48	49
1430 "	46	48
3.3 Mc/s.	66	64
7.0 "	67	74

A.V.C. characteristics

23. For A.V.C. tests the receiver is tuned to 210 kc/s. and the master switch set at A.V.C., the other receiver controls remaining as specified in para. 18. The test set switch, S₁, must be at M.W., and S₂ at 0 DEG.

24. Tune the signal generator to 210 kc/s. and set the modulation to 400 c/s., 30 per cent. Set the signal generator output to 100 microvolts. Adjust the receiver volume control to obtain an output of 10 mW. Increase the signal generator output to 10 millivolts. The receiver output should now be not greater than 32 mW.

Tests for D/F. reception

25. The general performance tests for D/F. reception are divided into two groups as under:—

Group 1.—Tests which are all taken at the same frequency.

Group 2.—Tests which are taken at predetermined spot frequencies, on each on the D/F. tuning bands.

26. The signal generator is connected to the receiver via the test set and the receiver and test set are initially set as follows:—

- Receiver wavechange switch on range 4.
- Signal generator set to 210 kc/s., carrier modulated 30 per cent at 400 cycles.
- Volume control at convenient level for monitoring.
- L.F. filter switched "in".
- Heterodyne switch "off".
- Switching oscillator control in LOW position.
- Test set switch S₁ in D/F. position.
- Test set switch S₄ in N position.

Adjustment of vertical aerial trimmer and check of D/F sense

27. Leaving the other receiver and test set controls as specified in para. 26, turn the receiver master switch to BALANCE. Adjust the signal generator output to 50dB up on 1 microvolt (see fig. 4). Now proceed as follows:—

- (i) Adjust the receiver METER AMPLITUDE control so that the visual indicator meter needles are at a convenient height.
- (ii) Adjust the METER BALANCE control until the visual indicator needles intersect on the centre line of the scale.
- (iii) Turn the receiver master switch to the VISUAL position.
- (iv) Then turn the METER AMPLITUDE control to the maximum clockwise position.
- (a) Put the test set switch S₂ in the 10-DEG. position. Turn the receiver deflection sensitivity control to the LOW position. It should now be possible to obtain three-quarters full deflection and quarter full deflection of the visual indicating meter, within the limits of adjustment of the aerial trimmer condenser C₆₆. Full deflection of the visual indicator needles is such that the lower needle is over the zero mark on the meter scale and the upper needle is well up near its upper limit.

- (b) With the test set switch S_2 still in the 10-DEG. position, turn the deflection sensitivity control to the HIGH position, put switch S_2 in the L position. Adjust receiver aerial trimmer C_{88} to give full scale deflection, which should be to the left. The aerial trimmer is now correctly set. Put S_2 in the R position and check that the meter gives full scale deflection to the right within the limits of the switch S_2 .

Check for false "on course" indication

28. A check must be carried out to ensure that the visual indicator needles do not rise again when the loop is turned 90 deg. off course. Meter balance must first be checked, injecting a signal as specified in para. 26 and 27, and having the METER AMPLITUDE control turned fully anti-clockwise. Carry out the test as follows:—

- (i) Turn receiver master switch to VISUAL
- (ii) Put receiver deflection sensitivity control at HIGH
- (iii) Turn test set switch S_2 to 90 DEG.

29. The needles should now be fully deflected within the + and - limits of the test set switch, S_2 , with S_2 in its L and R positions.

Check of deflection sensitivity control

30. Keeping the signal generator input level as in the preceding D/F. tests, carry out the following procedure:—

- (i) Return the receiver master switch to the BALANCE position.
- (ii) Adjust the meter needle intersection to some convenient height by means of the METER AMPLITUDE control.
- (iii) Check the balance.
- (iv) Turn the METER AMPLITUDE control to maximum.
- (v) Turn the receiver master switch to VISUAL.
- (vi) Put the deflection sensitivity control at LOW.
- (vii) Put the test set switch S_2 in the 25-DEG. position.
- (viii) The indicator needles should show full-scale deflection, within the \pm limits of the test set switch S_2 , for both positions of the switch S_2 .

D/F sensitivity at slow and fast switching speeds

31. With the signal generator output adjusted to the levels shown in Table 3, a sideways deflection of the meter needles exceeding $\frac{1}{8}$ in. must be obtained in the L and R positions of the test switch, S_2 , using both receiver D/F. switching frequencies. All the conditions of the test are shown in the table. Balance should be checked before the test is carried out.

TABLE III
Conditions of D/F. sensitivity test

Receiver					Sig. gen.	Test set switches			
Master switch	L.F. filter	Deflec. sensitivity	Meter amplitude	Switch speed	Output	S_1	S_2	S_3	S_4
VISUAL	IN	HIGH	Max.	LOW	30dB	D/F	L and R	25 DEG.	N
				HIGH	23-33dB				

Limiting check

32. Return the receiver switch speed control to the LOW position and the master switch to BALANCE. Adjust the visual indicator balance with the METER AMPLITUDE control at minimum. Inject a signal of 120dB. The indicator needles should not rise higher than the bottom of the L and R markings on the indicator scale.

Balance control check

33. Adjust the signal input level to 50dB up on 1 microvolt. Set the meter needle intersection to some convenient height by means of the METER AMPLITUDE control. Move the BALANCE control to the limit in both the clockwise and counter-clockwise directions and note limiting positions of the intersection of the needles. The intersections should not be less than $\frac{1}{4}$ in. from the centre on either side.

H.T. interlock check

34. Turn the test set switch S_1 to the m.w. position. It should now not be possible to operate the receiver in the BALANCE, VISUAL or "figure of eight" positions of the receiver master switch.

Aural sense check

35. With the signal input level at 50dB up, the receiver master switch at "figure-of-eight", and test set switch S_2 at 90 DEG., put the test set switch S_3 in the L position and move the receiver AURAL SENSE switch backwards and forwards between the L and R positions. The signal, as heard in the monitoring telephones, or as indicated on the output meter, should be considerably louder in the L position of the hand switch than in the R position. Move the test set switch S_3 to the R position and repeat the test. The signal should now be loudest in the R position of the hand switch.

Symmetry and sense of meter deflection

36. Checks of meter deflection symmetry and sense are carried out on three frequencies, injecting signals of the levels shown:—

Frequency	Sig. gen. input (dB above 1 microvolt)
80 kc/s.	52
210 kc/s.	50
650 kc/s.	50

37. The receiver controls must be set as follows:—

Switch speed	LOW
Deflec. sensitivity	HIGH
Meter amplitude	Max.
L.F. filter	IN
Het. switch	Off
Volume control	Any convenient level for monitoring

38. Check the meter balance on each frequency before making the test. Then turn the receiver master switch to VISUAL and place the test set switch S_2 at 10 deg.

39. In the above conditions full deflection of the meter needles should be obtained within the + and - limits of the test set switch, S_3 , with the test set switch, S_2 , at L and R.

40. Deflection should be to the left when S_3 is at L and to the right when it is at R.

H.F. breakthrough in H.T. supply leads

41. This test is for checking condensers C_{108} (H.T.-) and C_{21} (H.T.+). The receiver and test set controls are set up as below:—

Carrier frequency 210 kc/s.
Carrier modulated 30 per cent at 400 cycles
Receiver operational switch on "omni"
Volume control at maximum
Heterodyne switch "off"
L.F. filter "out"
Test set switch S_1 in the m.w. position
Test set switch S_2 in the 0-DEG. position
Adjust input level to give 50 mW. output.

42. Switch modulation off and note the noise level. (This should normally be between 1 and 10 mW.). With the modulation still off, inject 20 volts a.c. by means of the test set, type 112. The test requirement is that the output should not increase by more than 2 to 3 mW. when the 20 volts a.c. is applied. If the output increases to 30 mW. or more, one or other, or both the condensers C_{108} and C_{21} are faulty. To find which condenser is the faulty one, the following procedure may be adopted:—Clip a $4\mu\text{F}$ condenser between receiver chassis and H.T.+ on the receiver. If the output drops to about 5 mW. (10 mW. in the case of more noisy receivers) this indicates that

C_{91} across H.T. + is faulty. Clip a $4\mu\text{F}$ condenser between receiver chassis and H.T. — on the receiver. If the output drops to about 5 mW. (10 mW. in the case of more noisy receivers) this indicates that C_{108} across H.T. — is faulty. If the output falls by only a few dB when $4\mu\text{F}$ is put across H.T. —, then both condensers are faulty.

Lining up H.F. circuits

43. The signal generator is connected to the appropriate terminals on the test set. As the R.1155 is primarily a D/F. receiver on the M.W. and L.W. ranges (3, 4 and 5) and primarily a communication receiver on the S.W. ranges (1, 2 and 2A), it is essential that the receiver be lined up under these actual operating conditions. It must not be lined up with the operational switch in either the "omni" or A.V.C. positions on ranges 3, 4 and 5, nor on the short wave ranges (1, 2 and 2A) with the switch in any of the D/F. positions. Ganging on the S.W. ranges, 1, 2 and 2A follows conventional practice, but on ranges 3, 4 and 5 special methods for injecting the signal which simulate actual D/F. operating conditions must be employed.

44. Two methods can be used, both employing the dummy aerial contained in the test set. The second method given below has the advantage that it is not necessary to hold the receiver AURAL SENSE switch over when lining up.

Method 1

- (i) Connect signal generator to the fixed aerial (S_1 at s.w.).
- (ii) Set receiver operational switch in "figure-of-eight" position.
- (iii) Hold AURAL SENSE switch over to either L or R position.

Method 2

- (i) Inject signal generator voltage into dummy loop circuit (S_1 at D/F.).
- (ii) Set receiver operational switch to the "figure-of-eight" position.

The following test conditions are necessary:—

- (a) Volume control at maximum or adjusted so that the noise level does not exceed 1 mW.
- (b) L.F. filter switched out.
- (c) Deflection sensitivity control in the HIGH position.

Wave range	Position of receiver operational switch	Position of aural D/F. hand switch	Position of test set switch S_1	Position of test set switch S_2
M.W. and L.W. ranges 3, 4 and 5. Method 1	Figure-of-eight	Held over	D/F.	0 deg.
M.W. and L.W. ranges 3, 4 and 5. Method 2	Figure-of-eight	Normal	D/F.	90 deg.
S.W. ranges 1 and 2 ...	Omni	Normal	S.W.	—

45. The ganging operation follows normal practice. The signal generator carrier is modulated 30 per cent at 400 cycles and the output meter is used as a tuning indicator. The input level should be such that the output meter reading is of the order of 10 milliwatts.

APPENDIX I
NOMENCLATURE OF PARTS

This list of parts is issued for information only. When ordering spares for this equipment, reference must be made to Volume III of this publication, if available, or to the appropriate section of A.P.1086.

Stores Ref.	Nomenclature	Qty.	Ref. in fig. 2	Remarks
10S/137	Test set, Type 65			Metal box 10½ in. × 7½ in. × 5 in. approx., with carrying handle. Includes four connectors.
	<i>Principal components—</i>			
10S/544	Case	1		Metal, with 4 rubber feet
10C/80	Choke, H.F., type 54	2	CH ₁	1.25μH
10C/11228	Choke, H.F., type 357	1	CH ₂	3μH
10S/545	Coil, dummy loop	1	D.L.	Two windings, iron-dust core
	<i>Condensers—</i>			
10C/3066	Type 1476	1	C ₅	5.5—100μμF variable. Screwdriver adjustment
10C/11206	Type 3409	1	C ₆	40μμF
10C/11485	Type 536	1	C ₇	50μμF
10C/5055	Type 2725	1	C ₁	100μμF
10C/11207	Type 3410	1	C ₂	140μμF
10C/11208	Type 3411	1	C ₃	425μμF
10C/745	Type 831	2	C ₄ , C ₈	.0003μF
	<i>or</i>			
10C/2045	Type 950	2	C ₄ , C ₈	.0003μF
10C/14678	Type	1	C ₈	.002μF
10Q/2	Indicator, visual, type 1	1		Twin-needle
10A/14438	Knobs, type 217	4		For S ₁ , S ₂ , S ₃ , S ₄
10H/437	Plug, type 211	1		4-pole. Power supply
	<i>Includes—</i>			
10H/324	Plug, type 195	1		4-pole
10A/15660	Brackets, type 300	2		
10A/14871	Screws, mild steel	2		4 B.A. × ¼ in. long
	<i>Resistances—</i>			
10W/8610	Type 2116	2	R ₄ , R ₅	20 ohms
10W/997	Type 997	1	R ₄	100 ohms
10W/676	Type 867	1	R ₁	150 ohms
10W/110	Type 578	1	R ₂	300 ohms
10W/8611	Type 2117	1	R ₃	820 ohms
10W/11381	Type 477	1	R ₇	50,000 ohms
10H/442	Socket, type 178	1		8-pole. Receiver supply
	<i>Includes—</i>			
10H/1525	Socket, type 301	1		8-pole
10A/14866	Brackets, type 194	2		
10A/14871	Screws	2		4 B.A. × ¼ in. long
10H/327	Sockets, type 138	2		4-pole. Visual meter and dummy loop
10F/1190	Switch, type 953	1	S ₁	Single-wafer, single-pole, 6-position
10F/1191	Switch, type 954	1	S ₂	Single-wafer, 2-pole, 2-position
10F/1192	Switch, type 955	1	S ₃	Single-wafer, single-pole, 4-position
10F/1193	Switch, type 956	1	S ₄	Single-wafer, single-pole, 3-position
	Items required for 4 connectors supplied with the instrument—			
10H/455	Plug, type 221	1		8-pole
	<i>Includes—</i>			
10H/323	Plug, type 194	1		8-pole
10A/14848	Cover, type 243	1		
10B/1236	Insulator, type 402	1		
10A/14870	Screws, M.S., R.D., H.D.	2		
10H/794	Plugs, type 266	3		
	<i>Includes—</i>			
10H/324	Plug, type 195	1		
10A/14846	Cover, type 241	1		
10B/1234	Insulator, type 400	1		
10A/14870	Screws, M.S., R.D., H.D.	2		
10H/795	Socket, type 220	1		4-pole
	<i>Includes—</i>			
10H/327	Socket, type 138	1		4-pole
10A/14846	Cover, type 241	1		
10B/1234	Insulator, type 400	1		
10A/14870	Screws	2		4 B.A. × ¼ in. long

CHAPTER 4

ARTIFICIAL AERIAL, TYPE 21

(Stores Ref. 10B/906)

LIST OF CONTENTS

Introduction	Para. 1	Operation	Para. 4
General description	2	Components	5

LIST OF ILLUSTRATIONS

Artificial aerial, Type 21	Fig. 1	Circuit of artificial aerial, Type 21	Fig. 3
Rear view of artificial aerial	2		



Fig. 1.—Artificial aerial, Type 21

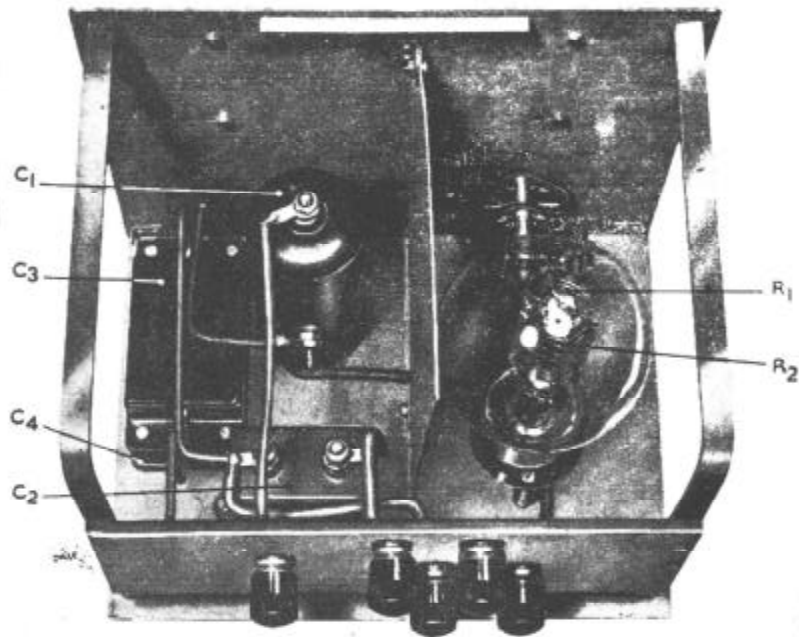

Fig. 2. Rear view of artificial aerial

INTRODUCTION

1. Artificial aerial, Type 21 is intended for use as a dummy aerial to facilitate service bench testing of low power HF and MF transmitters. Essentially it consists of four fixed condensers and a tapped, non-inductive resistance in the form of a lamp dummy load.

GENERAL DESCRIPTION

2. Two views of the artificial aerial, Type 21, are shown in *fig. 1 and 2*, and reference to these will show that it consists of a metal chassis contained in a perforated metal case to allow for dissipation of heat. A metal screen, dividing the unit, is fitted so as to isolate other components from the lamp load radiated heat. A three-position switch is provided on the front panel offering values of load resistance as follows:—

- 5 ohms at 100 watts
- 10 ohms at 50 watts
- 20 ohms at 100 watts.

3. On the side of the metal screen remote from the lamp load there are four condensers. Reference to the circuit *fig. 3* will show that four capacities are available by means of terminals which are mounted on a panel at the rear of the instrument. These capacities are 250 micro-microfarads for MF and 50 micro-microfarads, 100 micro-microfarads and 150 micro-microfarads,

micro-microfarads for HF working. Combinations of these values can be obtained by suitably connecting condensers C₂, C₃ and C₄ together by means of the terminals on the panel at the back of the instrument. An additional terminal on this panel provides the means of making an earth connection.

OPERATION

4. Operation of the artificial aerial Type 21 is quite straightforward. For example, for use with the transmitter T.1154 the \mathcal{A} terminal marked MF should be connected to the appropriate outlet in the transmitter, while the HF \mathcal{A} plug of the transmitter should be connected to that HF \mathcal{A} terminal of the artificial

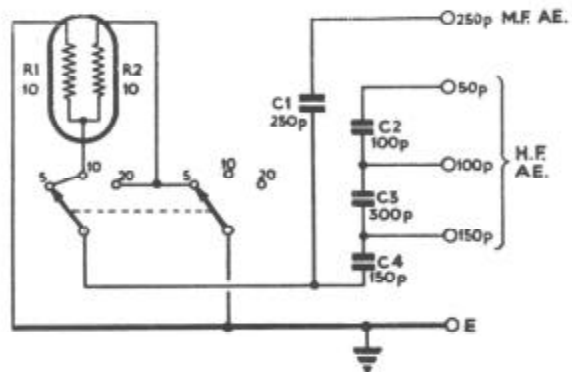

Fig. 3.—Circuit of artificial aerial, Type 21

COMPONENTS

aerial most suitable for testing the frequency range to which the transmitter has been adjusted. The earth terminal of the artificial aerial should be connected back to the transmitter earth plug. All connecting leads should be kept as short as possible.

5. The following are the Air Ministry type and Stores Reference numbers of the components mentioned in this publication and which may need renewal. The information given here may be added to, or superseded by Vol. II leaflets or by Vol. III.

Ref. No.	Nomenclature	Qty.	Ref. in Fig. 3	Remarks
10B/906	Aerials, artificial, Type 21 <i>Consisting of:—</i>			
10C/11823	Condenser, Type 3625	1	C ₄	·00015 μ F \pm 5%, mica, moulded, 3 $\frac{1}{2}$ in. \times 1 $\frac{1}{4}$ in. Test 2·5 amp. at 2·5 Mc/s.
10C/3847	Condenser, Type 1936	1	C ₁	·00025 μ F \pm 10%, moulded, cylindrical 1 $\frac{1}{2}$ in. dia. \times 3 $\frac{1}{2}$ in., with 2—2 B.A. terminals. Test 1 amp. at 150 kc/s.
10C/11825	Condenser, Type 3627	1	C ₃	·0003 μ F \pm 10%, mica, moulded, 3 $\frac{1}{2}$ in. \times 1 $\frac{1}{4}$ in. Test 2·5 amp. at 2·5 Mc/s.
10C/11826	Condenser, Type 3628	1	C ₂	·0001 μ F \pm 10%, mica, moulded, 2 in. \times 3 $\frac{1}{8}$ in. with 2—2 B.A. terminals. Test 2·5 amp. at 2·5 Mc/s.
10H/9615	Holder, valve, Type S	1		5 pin, Paxolin 1 $\frac{1}{2}$ in. dia., 4 fixing holes 1 $\frac{1}{8}$ in. P.C.D.
10A/11839	Knobs, Type 11	1		$\frac{1}{4}$ in. spindle, lozenge shape 1 $\frac{1}{2}$ in. \times 1 in. \times ·94 in. deep.
10F/1394	Switch, Type 1028	1		3 pole, 3 position, 2 wafer, shorting, 1·9 in. \times 1·54 in. \times 1·62 in. $\frac{1}{4}$ in. spindle
10H/7227	Terminal, Type C	5		4 B.A.
10E/772	Lamps, dummy load, 100 watt, 20/10/5 ohms	1		Gas filled, British 4-pin base

Chapter 5 LOOP AERIALS, TYPE 3 AND 4

LIST OF CONTENTS

	Para.		Para.
Introduction	1	Loop without housing	33
Constructional details		Loop with housing	36
Loop aerial, Type 3		Quadrantal error corrector	37
Loop construction	5	Housing	39
Support arrangements	6	Adjustment	41
Electrical connections	7	Loop without housing	42
Mounting and housing of loop	8	Loop in housing	43
Quadrantal error corrector	10	Alignment of the Type 3 loop	44
Loop aerial, Type 4		Alignment of the Type 4 loop	45
Loop construction	14	Sealing of housing	46
Support arrangements	15	Controller and indicator	47
Electrical connections	16	Casing	48
Mounting and housing	17	Shafting	49
Quadrantal error corrector	19	Anti-torsional units	50
Box drive	21	Calibration	
Control	25	General	51
Controller	26	Requirements	54
Indicator	27	Preliminary check	59
Shafting	28	Calibration procedure	62
Anti-torsional unit	29	Determination of quadrantal error	67
Installation		Operation	72
General	30	List of parts	Appendix I

LIST OF ILLUSTRATIONS

	Fig.		Fig.
Loop aerial, Type 3: showing winding on former	1	Remote control layout	10
Type 3 loop mounted in housing	2	Controller	11
Loop aerial in housing as mounted on aircraft...	3	Indicator	12
Quadrantal error corrector: (a) for Type 3; (b) for Type 4	4	Terminal plate connections: (a) Type 3; (b) Type 4	13
Loop aerial, Type 4: showing winding on former	5	Alignment fittings: (a) for Type 3; (b) for Type 4	14
Type 4 loop mounted in housing	6	Scale of box drive, with Q.E. correction curve ...	15
Box drive, Type 1	7	Scale of indicator, with Q.E. correction curve ...	16
Box drive, Type 2	8		
Mechanism of box drive	9		

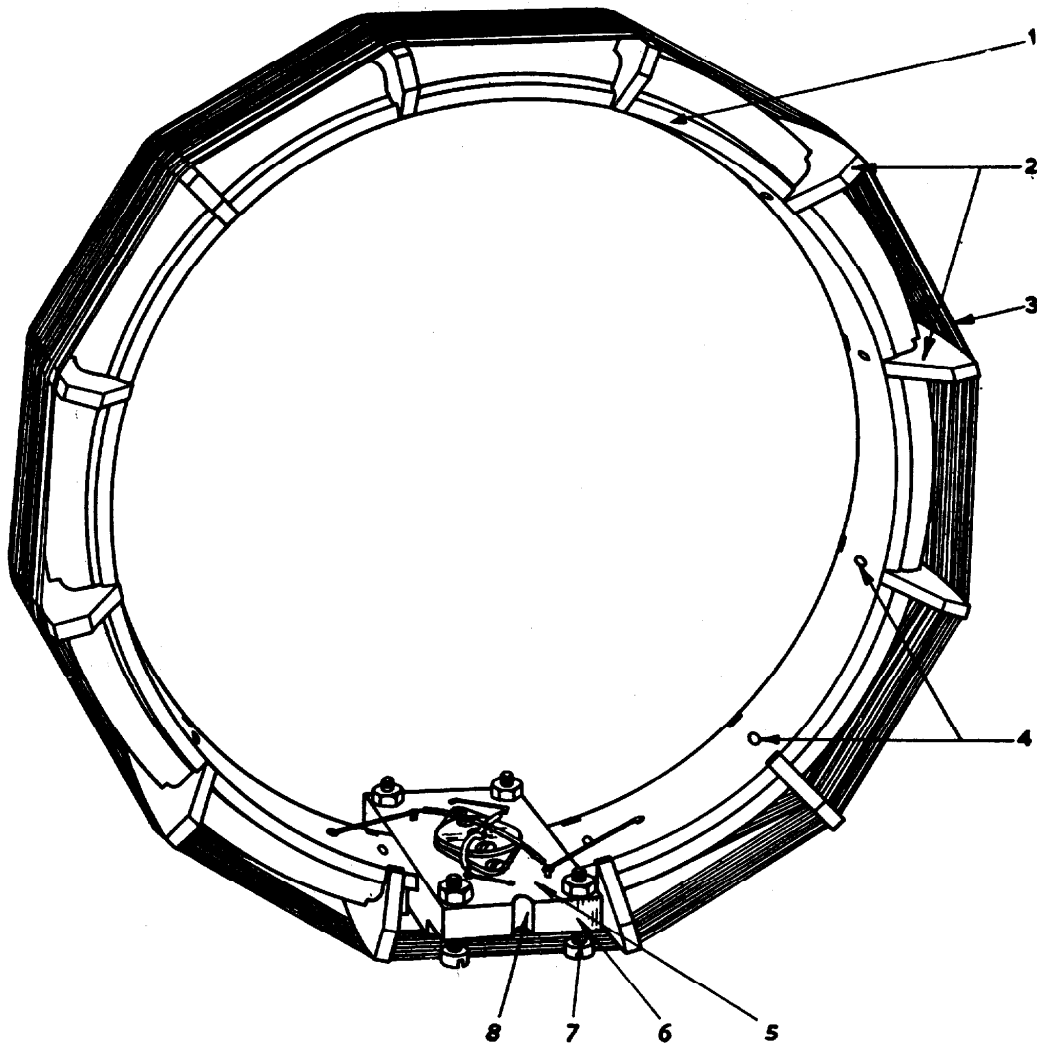

- | | |
|------------------------|------------------------|
| 1 FORMER | 5 TERMINAL PLATE |
| 2 SEGMENTS | 6 END PAINTED RED |
| 3 WINDING | 7 CRADLE FIXING SCREWS |
| 4 ASSEMBLY SCREW HOLES | 8 LOCATING SLOT |

FIG. 1. LOOP AERIAL, TYPE 3: SHOWING WINDING ON FORMER

INTRODUCTION

1. The loop aeriels, Type 3 and 4, are designed for installation in aircraft. The two types are electrically similar, but the Type 4 is smaller and, in general, is for use in smaller aircraft. The loops are used in conjunction with a suitable radio receiver, usually the R.1155, to obtain D/F bearings, or for homing on a fixed station.

2. The loop consists of a circular former around which is a winding which forms the loop aerial. The loop aerial is mounted on a rotatable base. It is usually mounted externally on top of the aircraft fuselage in a suitable streamlined insulated housing. In a few cases the loop, without its housing, is mounted within an insulating portion of the aircraft structure, but external to the metal-work. The Type 4 loop is provided with an electrostatic screen. The ends of the loop winding are carried through the base by suitable conductors and connected to the receiver.

3. The loop is rotated from within the aircraft, either through a handwheel directly connected to the rotatable part of the base, or by means of a mechanical remote control device. Where such remote control is fitted, a bearing indicator is usually provided at the control position, so that the orientation of the loop at any particular moment is known to the operator.

4. When the loop aerial is connected to the radio receiver, the operator is able to rotate the loop while listening to signals from a distant transmitter. The orientation of the loop giving minimum signal strength is noted. The bearing indicator then gives the apparent bearing of the transmitter, or its reciprocal, relative to the heading of the aircraft. After certain corrections have been applied, the bearing of the distant transmitter may be laid off on a chart or map.

CONSTRUCTIONAL DETAILS**Loop aerial, Type 3***Loop construction (fig. 1, 2)*

5. The loop is mounted upon a former (1) 10 in. in diameter made of moulded composition. This former has a cylindrical section with a supporting base and terminal plate (5) moulded integrally to it. Upon the

periphery are mounted 12 slotted segments (2) which carry the loop windings. These segments are held in position temporarily by a single screw (4) at the mid-point of each. The screws are removed when the former has been wound. The former, with segments attached, supports two sets of loop windings (3) which consists of a total of 16 turns of 18 s.w.g. tinned copper wire. These windings are disposed so that 8 turns are held in the slots on each side of the central position. The total inductance of the loop windings is about 100 microhenries which with the capacitance of the installed system gives a natural frequency of about 3.5 Mc/s. The ends of the two sets of windings are brought to the terminal plate (5) at the base of the loop former and are attached by soldering to connection spills which are fixed in the terminal plate. The two windings are connected in series. The wound loop has an approximate overall diameter of 11 in. and is 3 in. wide. It is carried on a cradle of cast aluminium (9, fig. 2), to which it is attached at its base with four screws and nuts (7). A slot in the base of the former and a pin on one leg of the cradle, both of which can be seen at (8, fig. 2), locate the loop former with respect to the cradle. The edge (6) of the loop former base in which the slot is provided is painted red.

Support arrangements (fig. 3, 9)

6. The requirements for mounting the loop are that it should be supported rigidly in position in the aircraft, whilst at the same time it is capable of being rotated about its vertical axis. In the majority of aircraft installations this is achieved as shown in fig. 3 by means of a tubular unit comprising an outer support tube assembly (4) which is rigidly fixed to the aircraft by a suitable clamp, not shown in the illustrations, and an inner drive tube (5) supported in the outer tube assembly by two ball bearings, the lower of which can be seen at (3, fig. 9). These ball bearings are packed with non-freezing grease and are suitably spaced to give vertical rigidity to the inner tube. In certain installations, the outer support tube has been dispensed with, and the loop is mounted directly on a shorter drive tube, thus eliminating the upper ball bearing. The tubes are steel, 2 in. and 1.25 in. outside diameter, respectively. The loop is mounted by its cradle on to the end cap (8) which is brazed on to the drive tube (5). To the other end of this tube the driving mechanism is attached with any

necessary registering scales or remote control device which may form part of the particular installation. The cradle and tube mountings are fitted with dowel pins, slots and holes to locate them with respect to each other. This is to keep the correct sense of the assembly when orientated with respect to the aircraft.

Electrical connections (fig. 3)

7. A short length of Dumet 4 cable (2) connects the loop windings to the cable run which in turn connects them to the receiver. The

is used to reduce capacitance effects to a minimum. Sockets and plugs have register guides and slots to enable the right polarity to be maintained throughout in the electrical connections. The sockets must be bonded to the metal frame of the aircraft. All cable connections must be made colour for colour throughout the whole cable run, that is, the same colours of the cable cores are connected together at cable joints, whether by plugs and sockets or direct connection.

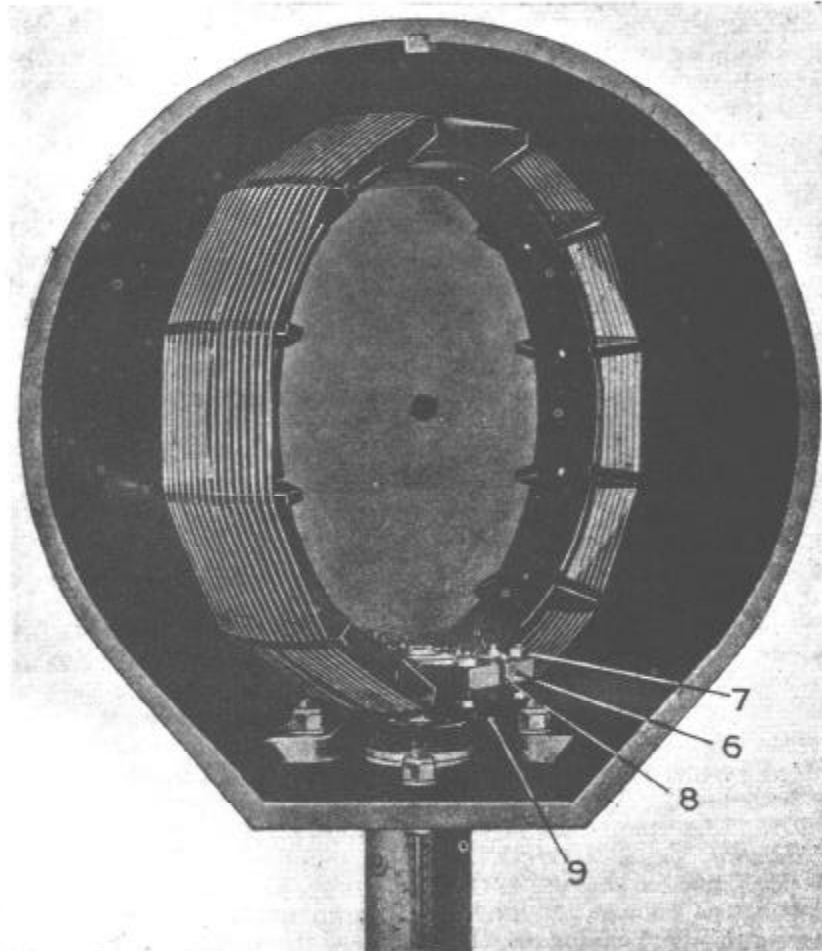

6 END PAINTED RED
7 CRADLE FIXING SCREWS
8 LOCATING SLOT
9 CRADLE

Fig. 2. Type 3 loop mounted in housing

Dumet 4 cable is clamped into the terminal plate at the base of the loop and passes down through the cradle and drive tube to a plug connection (1). It is essential that the length of this cable does not exceed 4 ft. 6 in. from the loop to the plug. The cable is connected directly to the radio receiver if possible. If, however, the distance is greater than 4 ft. 6 in. a length of Duradio 20 cable, with a suitable plug and socket is added; this type of cable

Mounting and housing of loop (fig. 2, 3)

8. The loop is mounted either in a streamline housing on the fuselage, or within the structure of the aircraft. In the latter case it must be mounted on and surrounded only by insulating material; it must not be enclosed by the metallic skin. Within specified limits and the requirements set out in this Chapter, aircraft contractors are given a certain latitude in the manner in which the loop is

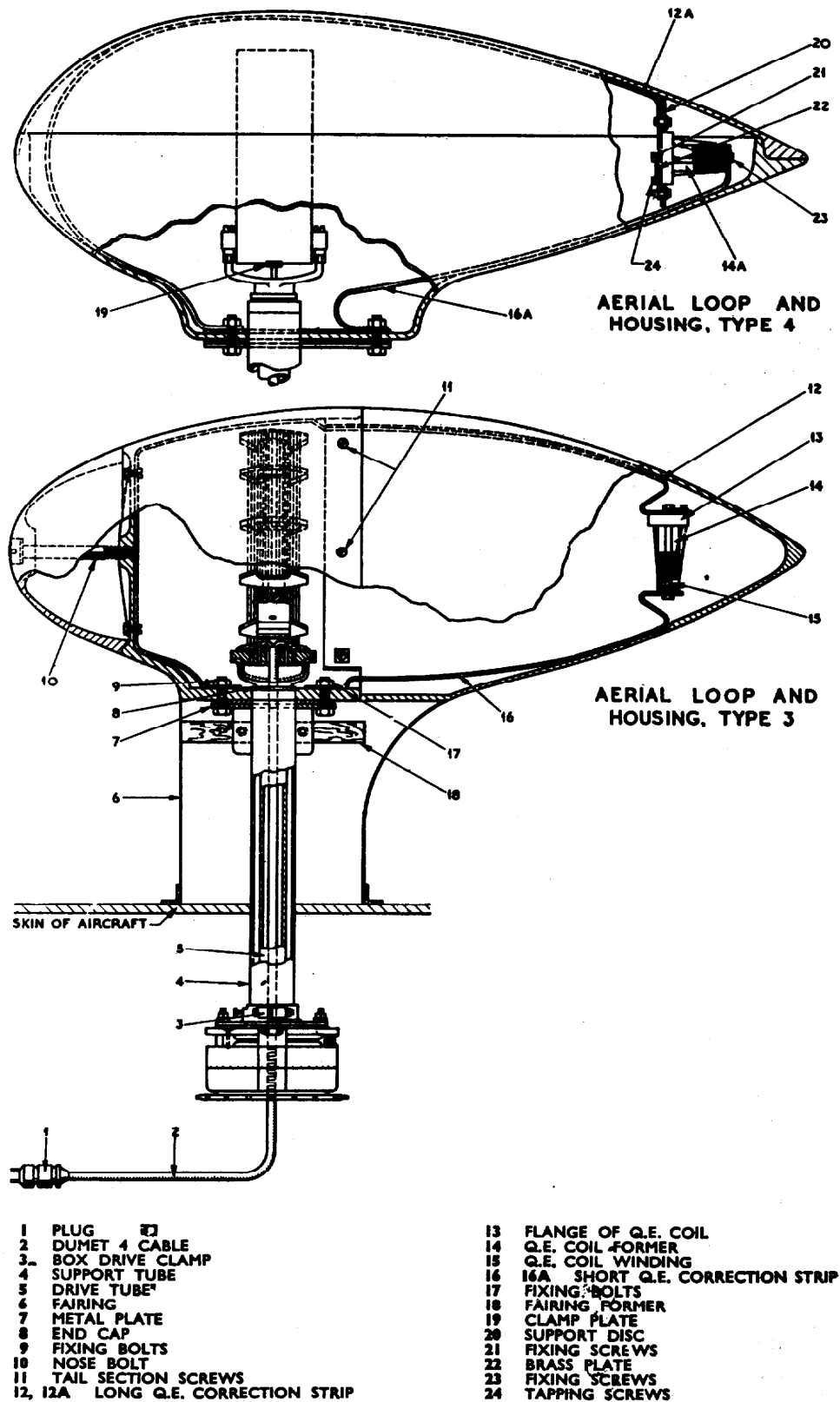

FIG. 3. LOOP AERIAL IN HOUSING AS MOUNTED ON AIRCRAFT

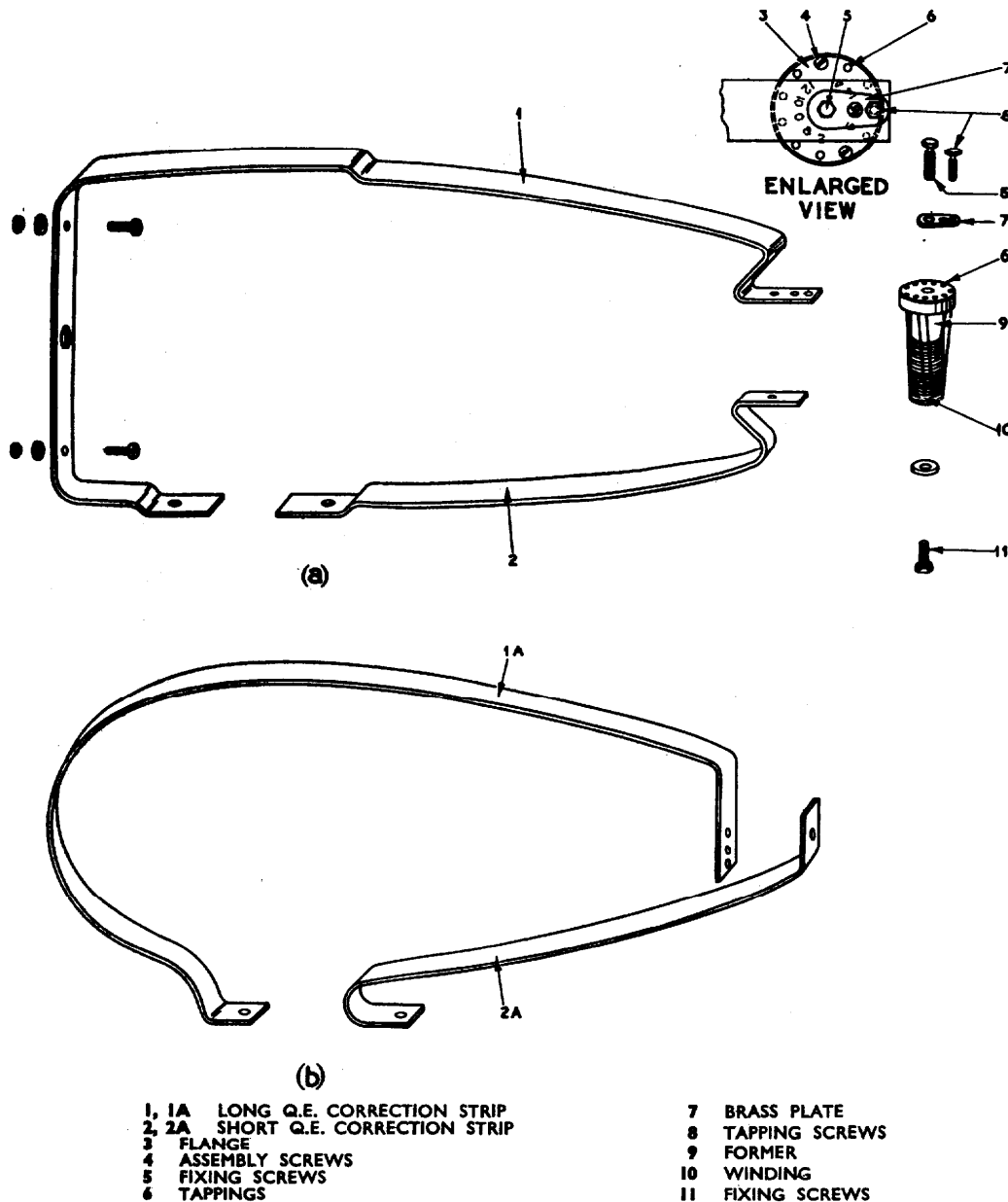

Fig. 4. Quadrantal error corrector: (a) for Type 3; (b) for Type 4

mounted on the aircraft. This includes also the actual mounting of the loop upon the tube assemblies which carry it and allow it to be rotated.

9. When the loop is mounted in a streamline housing on the fuselage of the aircraft, this housing has to be of special design. Its general outline and design is shown in *fig. 3*. The housing has a length of 3 ft. and a maximum diameter of 13 in. It is made of reinforced bakelite in three portions, nose, centre and tail, which are fastened together. The centre section is illustrated in *fig. 2*. The centre and tail sections are coupled by screws

round their periphery. The nose is clamped to the centre section by a single moulded composition screw (10) through the nose. The housing is mounted on the aircraft parallel to the line of flight with the nose facing forward.

Quadrantal error corrector (fig. 3, 4)

10. The quadrantal error corrector for the Type 3 loop is illustrated in *fig. 4* and it is shown in position in *fig. 3*. The corrector consists of two metal strips (12, *fig. 3*) forming a single-turn loop, which is mounted in the streamline housing and surrounds the D/F loop. A variable inductance (14) is in series with these strips, which are made electrically

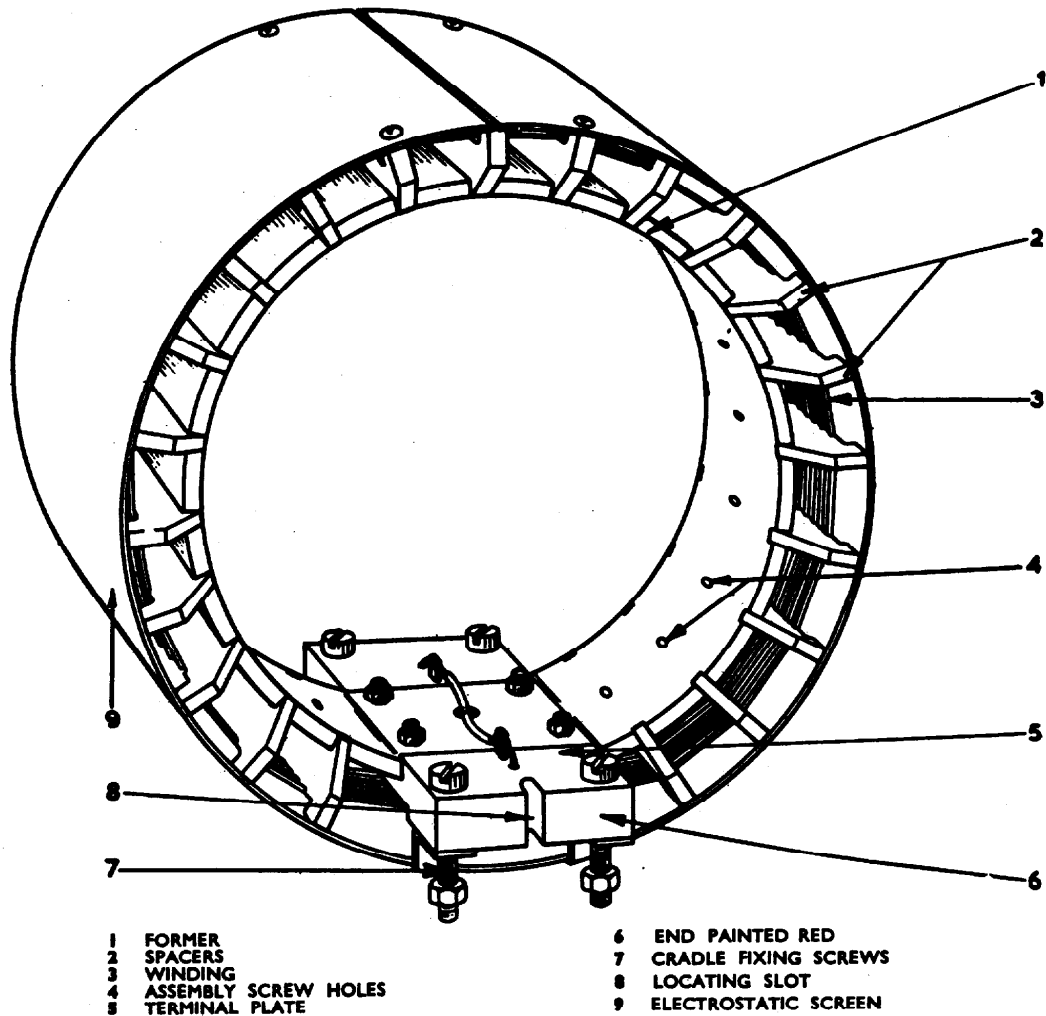

Fig. 5. Loop aerial, Type 4: showing winding on former

continuous and earthed through the metal plate (7, fig. 3) and bolts which clamp the tube assembly to the housing. By adjusting the value of the variable inductance, the local field is modified in a manner which corrects, within 2 deg., the quadrantal error due to the distortion of the field by the metallic structure of the aircraft.

11. The quadrantal error correction coil (9, fig. 4) consists of an ebonite former about 1 in. dia. and 3½ in. long. The winding of copper wire (10) around the cylindrical portion has tapings at 8 selected points; each tapping is connected to a stud (6) in the flange at the end of the former. The studs are set in recesses and each has a screw thread, so that by means of a hexagon-headed screw (8) electrical contact may be made to the brass plate (7). This plate is

attached to the upper correction strip (1) by a screw (5) through the larger hole. Through the centre hole can be seen markings denoting the tapping to which connection is made. These read in degrees in anti-clockwise sequence: 0, 10, 12, 4, 14, 16, 6, 2, 8. The other end of the winding is connected to the screw (11) at the remote end of the former.

12. The strips which are of brass of cross-section 1 in. by 0.036 in. are shaped to fit the housing and are attached to it at the flat portion behind the nose and at the bolts fastening the loop mounting to the housing.

13. The coil is fitted in a vertical position between the spring ends of the strips. The method of installation and adjustment of the tapings is explained in para. 37, 38 and 69 (3).

Loop aerial, Type 4

Loop construction (fig. 5, 6)

14. This type of loop is shown in fig. 5 and 6. The former (1) is $6\frac{1}{2}$ in. in diameter and cylindrical and is bolted to a moulded base (5). Around the former, mounted in slots, are 22 spacers (2) which carry the loop windings (3). The spacers are held in position temporarily by single screws (4) at the mid-point of each. The screws are removed when the former has been wound. The loop winding contains 20 turns of 20 s.w.g. tinned copper wire. Its inductance is the same as for the Type 3 loop, that is, about 100 microhenries. The ends of the winding are brought to tags on a terminal plate at the base of the former. An electrostatic screen of copper sheet (9) is fitted round the outside of the windings and is secured by screws to two of the top spacers. An airgap of 0.06 in. is left at the top. The loop has an overall diameter of approximately $7\frac{1}{2}$ in. and is about $2\frac{3}{4}$ in. wide. It is carried on the same pattern cradle (10, fig. 6) as the Type 3 loop; there is a similar locating slot (8).

Support arrangements

15. The support and drive tubes are similar to those used in the Type 3 (para. 6).

Electrical connections

16. The cable connections to the radio receiver are the same as for Type 3 (para. 7).

Mounting and housing (fig. 3, 6)

17. The external shape of the streamlined housing is similar to the Type 3 housing; it is, however, smaller (27 in. long and 10 in. dia.) and it is assembled rather differently. It consists of two sections, an upper and a lower. The upper section is fastened to the lower by screws around the horizontal periphery (upper half of fig. 3 and also fig. 6). It is mounted parallel to the line of flight with its nose facing forward. The material of which the housing is made is usually bakelised fabric, but other insulating materials, such as Perspex, have been used.

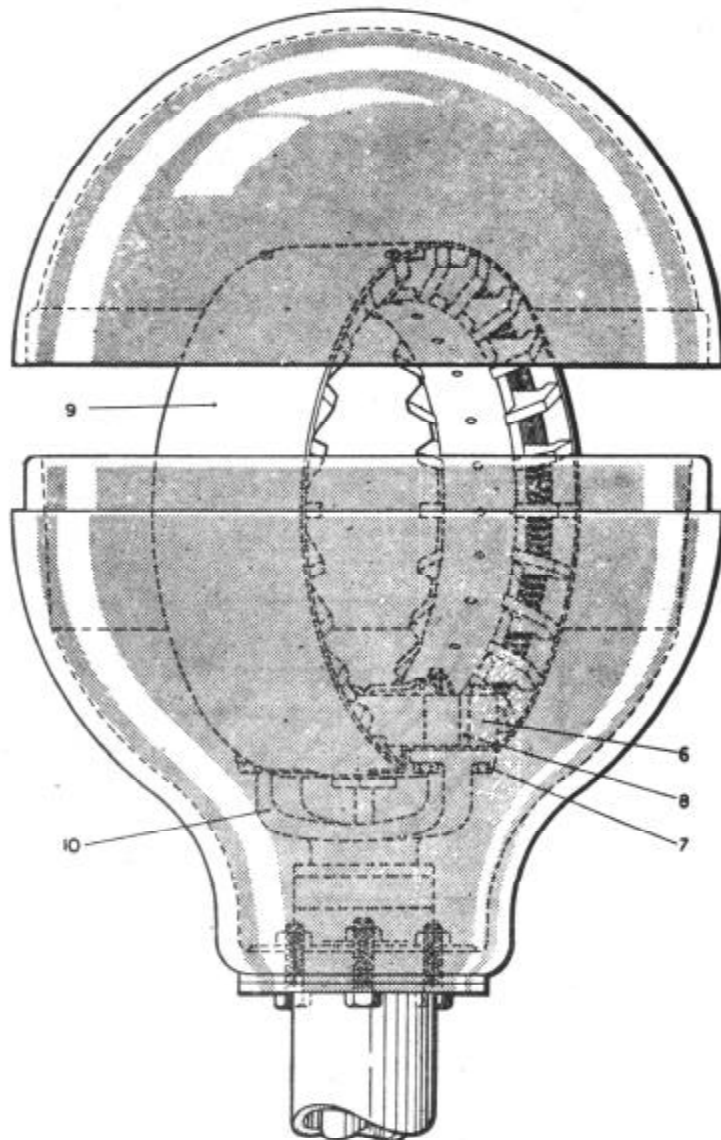

6 END PAINTED RED
7 CRADLE FIXING SCREWS
8 LOCATING SLOT
9 SCREEN
10 CRADLE

Fig. 6. Type 4 loop mounted in housing

18. When mounted within the aircraft structure, all supporting and surrounding material must be composed of an insulating substance and the loop must be outside the metallic skin.

Quadrantal error corrector (fig. 3, 4)

19. This consists of two metal strips with the corrector coil mounted in series with them. The principle and manner of adjustment are the same as for the Type 3 corrector. There are, however, slight differences which will now be described.

20. The coil former (9, fig. 4) is $2\frac{1}{4}$ in. long by 1 in. in dia. Access is obtained to the

tapping through the brass plate (7) and the connections to the strips are the same as for the Type 3. The coil is mounted horizontally between the ends of the strips and a support disc (24, *fig. 3*) is inserted at the flange end which fits the inside shape of the housing and keeps the corrector in position. The strips are consequently of different shape to those for Type 3, and the longer one (1A, *fig. 4*) fits the inside contour of the nose of the housing. For the method of installation and adjustment, see *para. 37*, [38 and 69 (3)].

Box drive (*fig. 7, 8, 9*)

21. Two types of box drive are available; both are suitable for use with either type of loop. Type 1, illustrated in *fig. 7*, is for remote control, and Type 2, illustrated in *fig. 8*, is for direct drive. Reference to *fig. 9* will show that in each case the box drive consists of two aluminium castings which fit one within the other. The outer or support tube (2) of the loop tube assembly is fixed to the outer casting (5), by means of a brass stamping (4) which is bolted to the casting. Inside this casting and bearing assembly is another casting (9) which is clamped to the drive tube (1) of the loop tube assembly. Two con-ended screws are provided, one (11) for the inner casting and the other (16) for the brass stamping to register them to the inner and outer tubes of the loop tube assembly respectively. They are fixed into position when final adjustments have been made.

22. Between the inner and the outer castings is formed a chamber in which is housed either a brake wheel (7) or a toothed wheel, according to whether the box drive is for direct or remote control. These wheels are of similar design and embody a stop plate (6) which is cut away for about 200 deg. of its circumference. A total rotation of 400 deg. is possible when the inner casting is rotated relative to the outer. The gear wheel or the brake wheel is attached by screws (13) to the inner casting and runs in the chamber which is formed between the inner and the outer castings. This chamber is completely enclosed

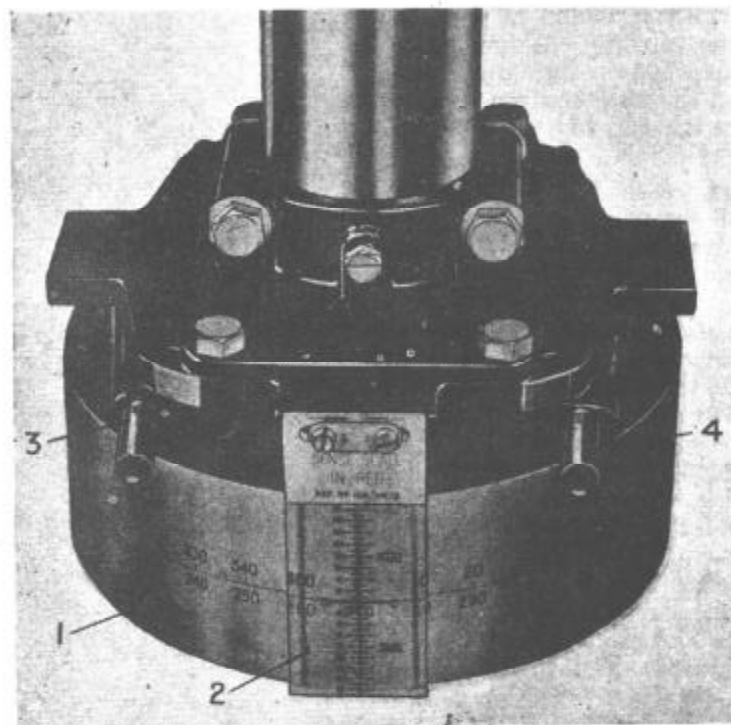

1 SCALE 2 CURSOR 3 and 4 GUIDE TUBES

Fig. 7. Box drive, Type 1

by a felt washer (8) held in a groove in the edge of the inner casting closing the space between the inner and the outer castings. Type 1 box drive includes a toothed wheel and two guide tubes (3) and (4) which can be seen in *fig. 7*. These are attached to the outer casting of the box drive and allow the shafting from the controller and indicator to be meshed with the toothed wheel. The casting adjacent to the ends of the guide tubes is painted red and yellow. These indication colourings are diametrically opposite each other, the yellow being on the left-hand corner as seen in *fig. 7*.

23. The Type 2 box drive includes a brake wheel, and reference to *fig. 8* will show that instead of the guide tubes which are incorporated in Type 1, there are two brake levers (5) and (6) with cork brake blocks attached to them. These brake blocks press against the brake wheel and lock the loop aerial in any desired position. The brake is used to prevent involuntary movement while taking a reading when a minimum has been obtained. Adjustment of the pressure on the cork brake blocks is made by loosening the nut (8) and removing the rod from the pin

(9). The rod may then be adjusted a turn either way, after which it should be locked by the nut (8). A cursor (2) is attached to the outer casting on the most convenient of any of the four lugs provided.

24. A skirt-shaped scale ring, shown at (1) in *fig. 7* and *8*, is attached to the inner mountings of the box drive. Its position and method of fixing are shown in *fig. 9*. The scale rings are engraved about the centre reading from 0 deg. to 360 deg., one above and one below the centre, the latter filled in red and displaced 90 deg. for sense indication. Referring again to *fig. 7* and *8*, it will be seen that outside this scale ring is a transparent cursor reading in degrees vertically up and down from a central zero, 0 to 16 up and 0 to 16 down. The up position is also engraved ADD, and the down position SUB. Its zero coincides with the scale line of

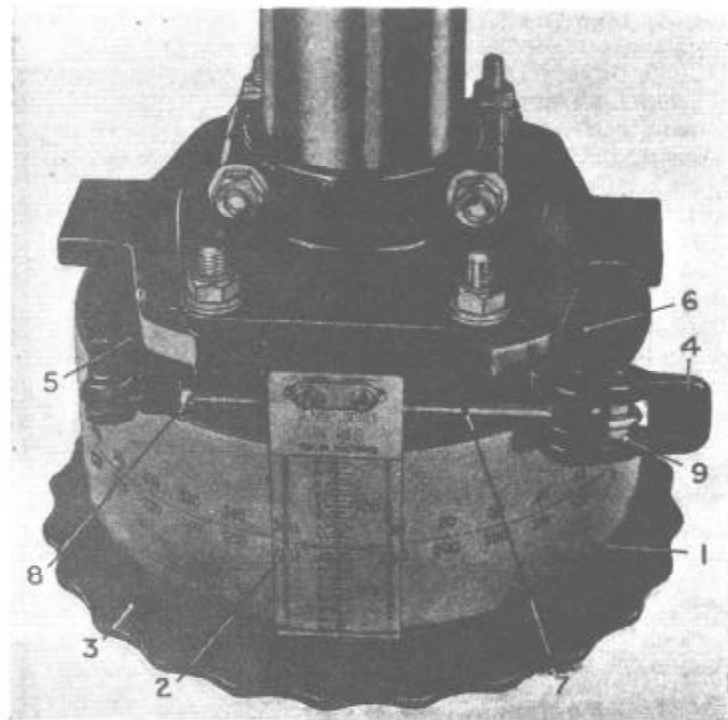

- | | |
|-----------------|----------------------|
| 1 SCALE | 5 and 6 BRAKE LEVERS |
| 2 CURSOR | 7 CONNECTING ROD |
| 3 HAND WHEEL | 8 LOCKING SCREW |
| 4 LOCKING LEVER | 9 PIN |

Fig. 8. Box drive, Type 2

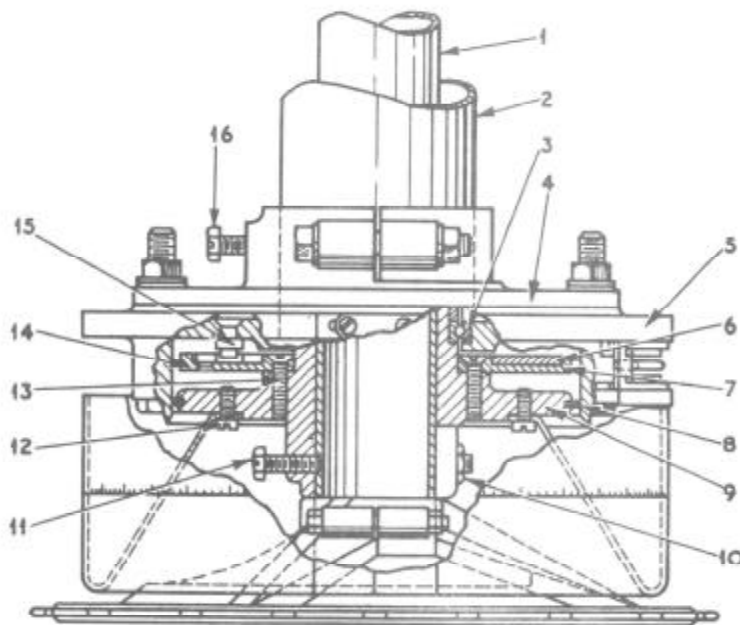

- | | |
|-------------------------------|--------------------------|
| 1 DRIVE TUBE | 9 INNER CASTING |
| 2 SUPPORT TUBE | 10 CLAMP BOLT |
| 3 LOWER BALL BEARING | 11 LOCKING SCREW |
| 4 BRASS STAMPING | 12 SCALE FIXING SCREW |
| 5 OUTER CASTING | 13 BRAKE (OR GEAR) WHEEL |
| 6 STOP PLATE | FIXING SCREW |
| 7 BRAKE WHEEL (OR GEAR WHEEL) | 14 and 15 STOP PINS |
| 8 FELT WASHER | 16 LOCKING SCREWS |

Fig. 9. Mechanism of box drive

the scale ring. The scale ring is finished to enable the quadrantal error correction to be plotted and drawn upon it in pencil. The cursor is attached to the support tube mounting and thus is stationary relative to the scale ring.

Control (fig. 8, 10)

25. The loop may be rotated either directly by means of the handwheel (3, *fig. 8*) or by remote control when the arrangement shown in *fig. 10* is used. The box drive, Type 1, (2), is rotated through flexible shafting (5) by the controller (6) and the reading on the scale is repeated on the indicator (4).

Controller (fig. 11)

26. This is simply a handwheel mounted on a gear box which gives a reduction of about $4\frac{1}{2}$ to 1. The shafting connecting the box drive to the indicator (*para. 28*) passes through the guide tube and engages with the gear wheels.

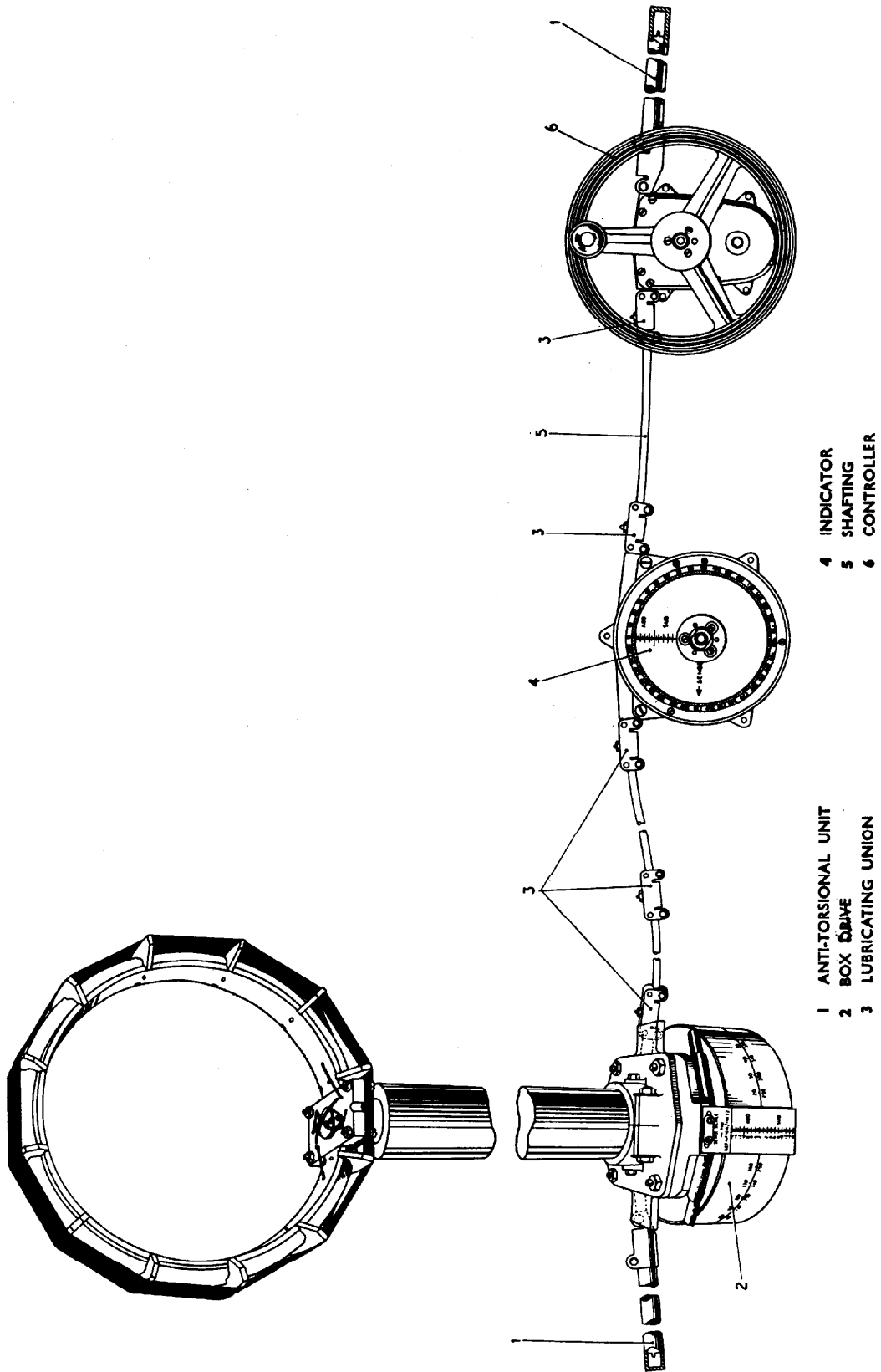

FIG. 10. REMOTE CONTROL LAYOUT

Indicator (fig. 12)

27. The indicator, which repeats the readings given on the scale ring mounted on the drive tube of the loop, is illustrated in *fig. 12*. It consists of a circular aluminium container housing a gear wheel. A guide tube is attached to the top of the container above the toothed wheel and is removable or can be swung clear for meshing or unmeshing the shafting. The front of the container is protected by a transparent covering and encloses a circular scale marked in degrees, from 0 to 360 clockwise. The scale is finished to enable the quadrant error correction curve to be plotted and drawn upon it. A circular transparent cursor is attached to the fixed portion of the hub of the indicator by three screws in slots which are provided to facilitate zero adjustment. This cursor has a scale engraved upon it, up and down from a central zero, 0 deg. to 16 deg. up and 0 deg. to 16 deg. down. These markings are inverted on the other side of the central scale to facilitate reading when the cursor is rotated. The up position is engraved ADD and the down position SUB. The lugs of the casting adjacent to the ends of the guide tubes are painted red and yellow respectively. This is to ensure the correct connection of the casing, as is described in *para. 48*.

Shafting (fig. 10)

28. The shafting, which connects the controller to the box drive and the indicator to the box drive, is flexible and is known as shafting, flexible, Type E2. It carries a continuous helix with 9 turns to the inch upon its periphery which engages with the toothed wheels in the controller, indicator and box drive. It runs in tubular casing known as casing, rigid, Type E2. This casing, which can be seen at (4) in *fig. 10*, is attached to the aircraft structure by suitable cleats, and is bonded to the frame of the aircraft at frequent intervals. Lengths of the casing are connected together and the casing is connected to the guide tubes of the controller, indicator and box drive by lubricating unions, Type E2, (3). The shafting does not revolve, but travels forwards and backwards in the casing, any overrun portion being taken up by the anti-torsional units.

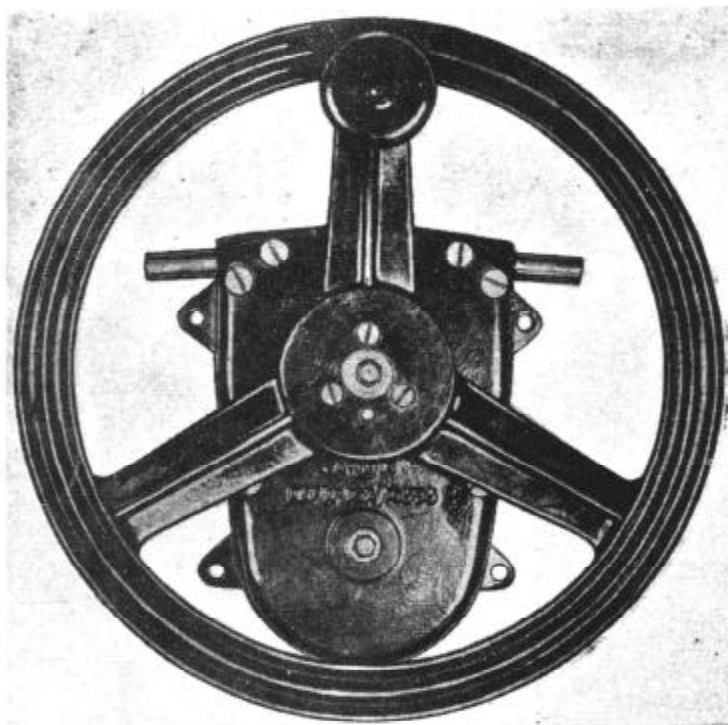

Fig. 11. Controller

Anti-torsional unit (fig. 10)

29. Both ends of the shafting have anti-torsional units (1, *fig. 10*) fitted to prevent any tendency on the part of the indicator shafting to twist in operation. This would introduce an appreciable error between the readings of the scale on the box drive and the indicator scale. The anti-torsional unit consists of an extension tube which has an elliptical instead of a circular bore. A metal bead, also of an elliptical cross section, is secured firmly to the shafting and runs smoothly in the tube. Any tendency on the part of the shafting to twist is prevented by the bead which allows free movement of the shafting to and fro in the casing, but prevents any twisting.

INSTALLATION

General

30. The exact disposition of the various parts of the loop and its control equipment cannot be given, as this varies with each individual type of aircraft. The method employed to rotate the loop depends on the position of the loop in relation to the operating station. The aircraft designers are responsible for the actual fixing details in each aircraft within certain limits, but the basic requirements, as set out in this chapter, remain the same and are applicable to all types of aircraft. In detail, the actual attachment of the support tube of the tube assembly may vary in method, both as to how it is

secured to the structure of the aircraft and to the housing fairing former, but there are certain specified strength requirements for this mounting which have to be fulfilled.

31. The fixing may involve a variation of the actual distance between the loop cradle and the box drive requiring the tube assembly to be lengthened. When this is necessary in Type 3 installations, extension tubes, each of the same length, are joined on to the support and torque tubes by muffs. The only length of tube available for the Type 3 loop is 3 ft. and if a shorter length is required it must be cut down accordingly. For a Type 4 installation a series of support and drive tubes of different lengths is available. When the length of support tube is increased, the Dumet 4 cable may need increasing also; the maximum length of 4 ft. 6 in. from loop to plug must not, however, be exceeded.

32. It is most important that before assembly, all moving parts of the installation should be thoroughly cleaned and lubricated with non-freezing oil or grease, as appropriate. This applies in particular to the drive and support tubes and to the shafting. Efficient operation is impossible unless these parts can move freely. The casing should be cleaned with paraffin, using a cleaner, casing, Type E1 (Stores Ref. 10J/11275), and the bore checked for correct clearance with a tester, casing, bore, Type E1 (Stores Ref. 10J/11276).

Loop without housing

33. The box drive should first be secured to the aircraft structure, in a convenient position for the operation of the loop, by means of the four screws which project from it. It should be so disposed that when remote control is to be used, the guide tubes are in a favourable position for the run of shafting to the controller and indicator, and the cursor is so positioned that it can be read accurately. A choice of four positions for the cursor is available on the drive. The tube assembly can then be slipped into the box drive and the top clamp tightened. The

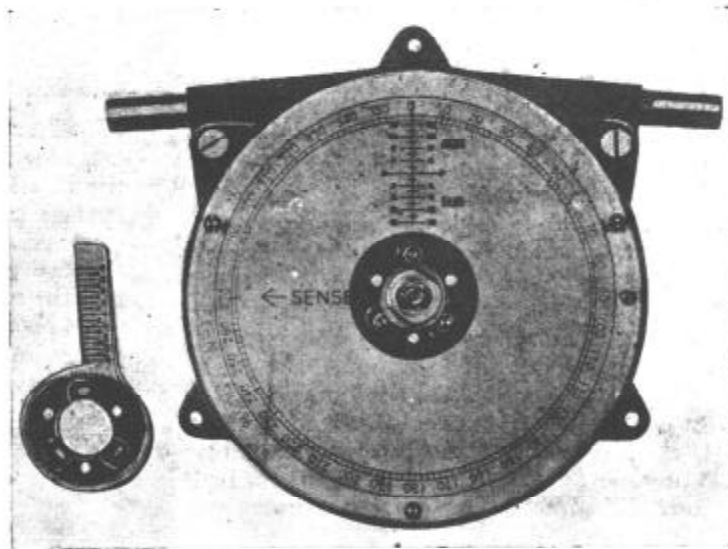

Fig. 12. Indicator

cradle should next be attached to the tube assembly. A locating dowel pin is provided on the cradle which should enter the hole provided on the tube assembly. The cradle should be locked into position by means of a fixing nut which screws on to the threaded portion at the top of the tube assembly.

34. The loop can now be attached to the cradle, but first the Dumet 4 cable should be fitted. This cable is connected to the loop windings at the flat base portion of the loop former. The arrangement for Type 3 is shown in fig. 13 (a). The braiding of the cable should be cut back $1\frac{1}{2}$ in. The circular plate (1) is then removed and the cable screwed up through the central sleeve until sufficient wire and about one inch of braiding has been screwed up past the top of the base. The braiding should be spread over the flat surface of the former base and the circular plate replaced and screwed down, thus clamping the braiding securely between the plate and the flat end of the sleeve. The cable wires (5 and 6) should be soldered to the tags or spills (2) on the inner flat surface of the loop former. The red lead is connected to the tag nearest the end of the former painted red and the blue lead to the tag at the other end. The other two tags to which are connected the inner ends of the windings must be joined with a length of 18 s.w.g. insulated wire as shown in fig. 1 and 13 (a). The cable is then threaded down the tube and the loop is attached to the cradle by four screws (7, fig. 1). A pin fixed into the cradle locates

the position of the loop by fitting into a slot (4) in the base of the loop former (para. 5).

35. The connection of the cable to the Type 4 loop is shown in *fig. 13 (b)*. Here the cable is first screwed through the hole in the clamp plate (1A), allowing 2 in. to project. Then 1 in. of braiding should be removed from the end of the cable and spread out over the surface of the clamp plate. The leads are fed through the hole in the centre of the former base and the hole in the screen. The clamp plate is screwed down, thus securing the strands of braiding against the underside of the screen. The red lead (5A) is then soldered to the tag (2A) nearest the end of the former painted red and the blue lead (6A) to the tag at the other end. The loop assembly can now be fitted to the cradle as described in *para. 32*. Instructions for adjustment are given in *para. 42*.

Loop with housing (fig. 3)

36. The support tube of the tube assembly is attached to the aircraft by a suitable clamp at the end of the tube assembly which enters the aircraft structure. This tube is then also attached to the housing fairing former at the loop end. Reference to *fig. 3* will show the general features of this assembly and attachment. The housing fairing former (18) is of spruce and in two portions, split along the centre line. These two portions are clamped together, and grip the support tube. The drive tube is then passed up into the support tube until its shoulder is against the ball race

of the bearing. The cradle is fitted in position, and the loop, with cable fitted, attached to the cradle.

Quadrantal error corrector (fig. 3, 4)

37. The quadrantal error correction device can now be fitted. Its general disposition in the housing is shown in *fig. 3*. The wooden spacing piece, which is sometimes in position on delivery, should be removed from between the tail ends of the strips of the corrector, and the coil fitted into this space, i.e. between the free ends of the strips. The supporting disc must be placed in position at the flange end of the coil in Type 4. The coil is fitted with the marked head at the tail end of the long strip by means of the two larger screws (5) and (11) *fig. 4*, which should be loosely fitted at this stage. Two soft metal washers are placed between the strips and the screw heads.

38. The coil can be rotated between the strips and when so rotated, the markings 0, 8, 2, 6, 16, 14, 4, 12, 10, on the top of the coil, appear in turn in the hole in the long strip. These details can be seen in *fig. 3*. The coil should be rotated until the marking 0 appears, when the selector screw (8) should be inserted into its socket. In this position the correction device is inoperative. When the selector screw has been tightened, it should be locked by turning up the end of the plate (7) against one of the sides of the hexagon head of the screw.

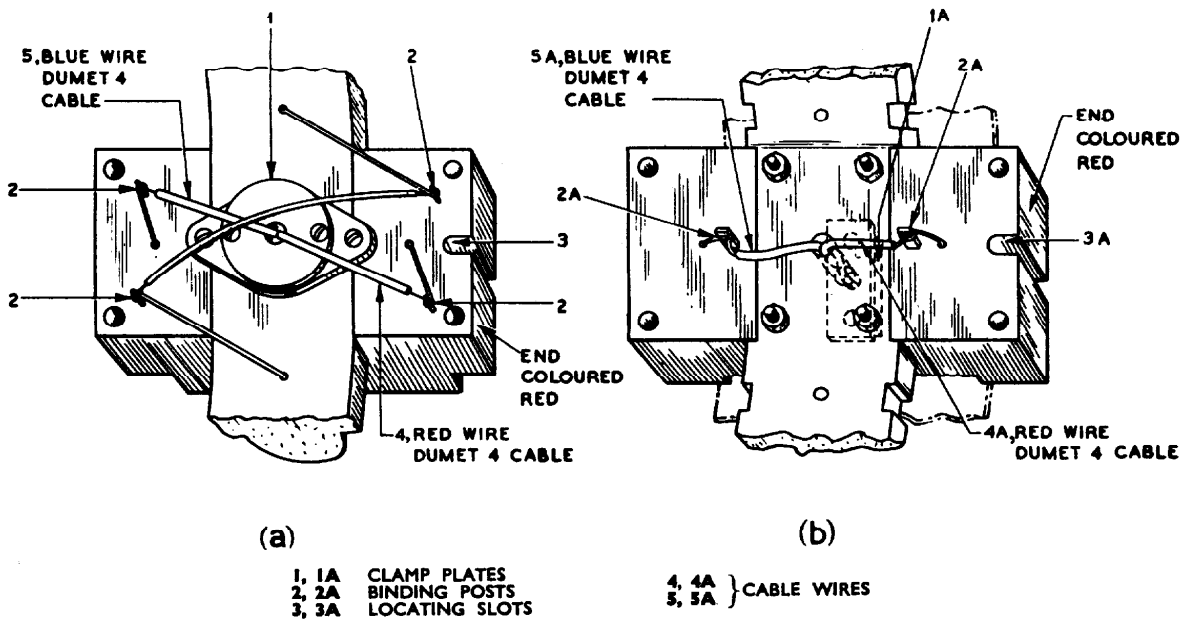

Fig. 13. Terminal plate connections: (a) Type 3; (b) Type 4

Housing (fig. 3)

39. The housings are illustrated in fig. 3. For the Type 3 loop, the centre section is attached to the housing fairing former (18) by a bracket to which it is bolted and the nose and tail sections are then attached. The lower section of the housing for the Type 4 loop is bolted to the fairing former in a similar manner. The upper section is then attached to it by screws around its horizontal periphery. The fairing (6), which encloses the tube assembly is of sheet aluminium, 22 s.w.g. Its height naturally depends upon the height of the loop, but it is usually about 10 in. when the loop is mounted on the axis of the aircraft. It is sometimes mounted upon an inner former to keep its shape and it is fastened to the skin of the aircraft by a suitable flange and to the housing at the housing fairing former line.

40. The position of the housing on the aircraft is governed by the design of the aircraft to a considerable extent. It is desirable that it should be mounted on the centre line of the aircraft at a point as near as possible to the centre if the area. This is the point where the centre lines of fuselage and wing cross. Here the quadrantal error will be a minimum. As mentioned previously, the housing must be parallel to the line of flight with the nose facing forward.

Adjustment

41. The usefulness of results obtained with the loop depend primarily upon the accuracy of the setting up of the loop with respect to the aircraft heading and every effort must be made to ensure this accuracy.

Loop without housing

42. When the loop (either Type 3 or 4) is mounted without the streamlined housing, the procedure for adjustment is as follows:

- (1) The clamp bolts on the box drive are slackened.
- (2) With the red end of the former and crad facing aircraft, the plane of the loop is set athwartships with an accuracy of within $\pm \frac{1}{4}$ deg. and held in position.
- (3) The lower part of the box drive is then rotated in a clockwise direction (when viewed from underneath) until a stop is reached. It is then turned back about 20 deg. when the cursor should read 180 deg. on the black scale.

- (4) The clamps are tightened and the set-screws are removed. Drill through the tapped holes into the tube beneath, using a No. 26 drill. Replace the set-screws. The scale will now rotate through 360 deg. plus 20 deg. on each side of 180 deg., making 400 deg. in all.

Loop in housing

43. For the adjustment of a loop mounted in a housing, the housing is aligned first. It must be set up fore and aft to an accuracy of within $\pm \frac{1}{4}$ deg. This is done using a line along the fuselage between datum blocks and setting the housing with reference to this. The loop is then aligned accurately across the housing as described in the following paragraphs.

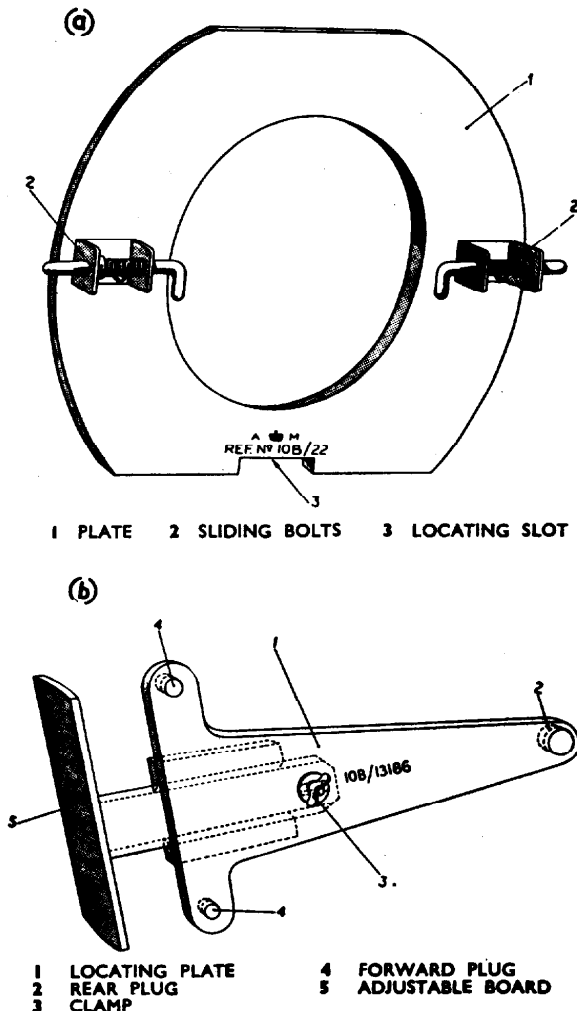

Fig. 14. Alignment fittings:
(a) for Type 3; (b) for Type 4

Alignment of the Type 3 loop (fig. 14(a))

44. The loop is set athwartships with the red ends of the former and cradle toward the rear and the fitting, alignment, D/F loop, Type 3 (Stores Ref. 10B/22) fixed in position with the two sliding bolts (2) located in the two screw holes in the rear of the centre section of the housing. The loop then lies firmly against the plate of the fitting (1) with the end of the former in the space (3). The operations detailed in *para. 42* are then performed. When the loop has been correctly aligned, the Q.E. corrector and the tail section of the housing can be fitted in position.

Alignment of the Type 4 loop (fig. 14(b))

45. The fitting, alignment, D/F loop, Type 4 (Stores Ref. 10B/13186), is placed horizontally in the rear end of the open housing so that the circular wooden plug (2) at the end of the locating plate (1) registers in the extreme tail end of the housing and the two forward plugs (4) are sprung inside the slightly flexible sides of the housing. The adjustable board (5) at the forward end of the fitting, which has previously been slack, is moved up to register firmly against the rear face of the loop former and then locked in position with the wing nut (3). The adjustments detailed in *para. 42* are then made, after which the Q.E. corrector and the upper section of the housing are fitted.

Sealing of housing

46. After calibration has been completed, and the Q.E. corrector adjusted to its proper setting, the housing must be sealed against the entry of any moisture. This must also be done, of course, after any subsequent opening of the housing. A rubber gasket is provided with the Type 3 housing for sealing the joint between the tail and centre sections. When all the screws have been tightened, the seams between tail and centre sections in Type 3 and between the upper and lower sections in Type 4 are sealed using a 2 in. wide cotton tape (Stores Ref. 32B/409) and special adhesive, Boscolyn lacquer (Stores Ref. 33C/590). Approximately 10 ft. will be required for the Type 3 housing and about 20 ft. for Type 4. Care must be taken to ensure an even surface, the tape being cut to lie smoothly over the pointed end of the housing of the Type 4 loop.

Controller and indicator

47. When the loop and its housing and drive equipment have been fixed into position and adjusted, the indicator and controller are

installed. Each is fixed to the aircraft structure by screws, using the lugs provided. Convenience for fixing the casing which carries the shafting is a factor of importance when locating the indicator and controller.

Casing

48. The casing is attached to the aircraft structure by cleats, and is joined to the guide tubes of the box drive, controller and indicator by lubricating unions. It is essential when fixing the casing to avoid sharp bends and to ensure that the total of all the bends between the box drive and the controller and indicator does not exceed 360 deg. The connection of each unit to the other is by the rule of colour to colour, i.e., red to red and yellow to yellow.

Shafting

49. When the equipment has been assembled and the casing fixed, one screw should be removed from each of the four guide tubes and each tube, at the free end, swung out clear of the worm gear wheel. The correct length of shafting is cut with a bolt cropper and the ends ground to a cone. Each length should then be inserted into its respective casing run, through the guide tubes. Both the loop and the indicator should then be rotated until they each register 0 deg. and, having made sure that in each case the shafting extends equidistantly from each guide tube, they should be swung back into position and the retaining screws replaced and screwed up. When swinging the guide tubes back into position care should be taken to ensure that the shafting and toothed wheel mesh properly.

Anti-torsional units

50. The drive box indicator shafting requires anti-torsional units fitting to the free ends of the guide tubes of the box drive and indicator. These are attached by means of the unions provided which are clamped to the guide tubes. The beads are then assembled by clamping them one to each end of the shafting by the screws provided in each bead, after which the anti-torsional tubes are passed over the beads and clamped by the unions. Minor adjustments to give exact coincidence between cursor and dial and between the box drive scale and the indicator should be made at this stage, after which all clamps and screws should be finally tightened.

CALIBRATION

General

51. After installation, and at certain times thereafter, D/F equipment must be cali-

brated in order to ascertain the magnitude and distribution of the errors due to distortion of the electro-magnetic field by the metallic structure of the aircraft. These calibrations must also be checked in flight.

52. A re-calibration must be carried out whenever any of the following conditions occur:—

(1) If a serious discrepancy is revealed between the ground calibration and the results obtained in the air.

(2) When any major modification is made to the aircraft structure, for example, the addition of armour plating, a change of engine or fuel tank within the fuselage, the addition or removal of a fixed W/T aerial or aerial mast, or any major structure external to the aircraft.

(3) In the case of an aircraft of wooden or composite construction, when any modification or repair is made to the aircraft bonding system in the vicinity of the D/F loop.

(4) Every three months, i.e., when the compass is reswung.

53. The errors which can affect D/F readings vary in magnitude, reaching a maximum value in each quadrant of relative bearing, and are therefore usually referred to as quadrantal errors. The maximum errors, however, rarely occur exactly at the quadrantal points. They are usually from about 3 or 4 deg. to as much as 20 deg. in amplitude and, when large, have the effect of giving blurred minima. A complete calibration, that is, a series of readings on at least 40 points, must be performed on each band to be used if these are more than 500 kc/s apart. Otherwise, if a complete calibration is made on one waveband, it must be checked carefully on not less than 8 points on the other band.

Requirements

54. The calibration must be performed by competent personnel with a knowledge of navigation. The essential requirements are a suitable site and suitable sources of radio signals.

55. With regard to site and apparatus required, A.P.1186, Sect. 6, Chap. 9, should be consulted. In general, the site must be an open level one, well away from trees and buildings, especially metal hangars. It must

be hard enough for an aircraft to be turned upon, but care must be taken that there is no steel reinforcement in the site or in adjacent runways. Underground cables will also give trouble and must be avoided. The compass swinging site will be suitable only if it satisfies these conditions.

56. It will usually be found that under normal conditions, broadcasting stations will be satisfactory as signal sources. These should be within 150 miles but not in the immediate vicinity. The sources chosen, with their frequencies and bearings, should be noted for future use.

57. Having chosen the signal source or sources to be employed, the true bearing of these stations, at the site where calibration is to take place, should be measured accurately by means of a suitable map and protractor. The true bearing, thus found, must be converted into the magnetic bearing by applying the magnetic variation, the value of which usually may be obtained from the map from which the bearings are taken. The magnetic bearing must be used for the purpose of calibration.

58. Alternatively, the bearing of the source may be found by using a free D/F loop on a suitable mounting with a battery-operated receiver such as the R.1082. This equipment will provide a bearing of the source from the site which can be used as a reference. Further details will be found in A.P.1186, Sect. 6, Chap. 9.

Preliminary check

59. The following preliminary tests of the D/F equipment should be made before the aircraft is taken to the calibration site.

(1) The D/F loop should rotate easily in its bearings without play.

(2) The scale and cursor should be examined for security, and also to verify that they are easily readable without parallax error. Where a remote indicator is also fitted, the readings on the scale on the box drive and on the indicator should agree to within $\pm \frac{1}{2}$ deg. at several points on the scales. (Owing, however, to the possibility of "backlash" error, the calibration should be done, whenever practicable, using the box drive scale rather than the scale on the remote indicator).

(3) The connections of the D/F loop to the receiver should be examined carefully,

and it should be ascertained that the combination of loop aerial and receiver is working normally. In particular, close attention should be paid to the following:—

(a) The connections and cleanliness of the plugs and sockets at the loop and at the receiver.

(b) The electrical contact between the metal earthing flange on both loop and receiver and the metal screening of the cable connecting the two.

(c) Continuity in both leads of the Dumet 4 and the Duradio 20 cable connecting the loop and the receiver.

60. On arrival at the site, the aircraft should preferably have its fuselage raised into the flying position on a tail trolley, but this is not always possible and is less necessary with very large aircraft.

61. With the aircraft heading approximately towards the signal source, a check should be made that the equipment is working properly. The minima should be sharp enough to read to an accuracy of $\pm \frac{1}{4}$ deg., and the reciprocal bearing should be 180 deg. from that of the true, to an accuracy of the same order. If these conditions are not satisfied, an observation should be made on another signal source, and if this also proves unsatisfactory, the installation should be examined for electrical defects in either loop or receiver.

Calibration procedure

62. When it has been ascertained that the complete installation is satisfactory, calibration may be commenced. It is most important that this is undertaken during the period between two hours after sunrise and two hours before sunset to avoid irregular ionospheric reflections or "night effect".

63. The aircraft heading is set using a medium landing compass (Stores Ref. 6B/034). This should be set up on its tripod as far away as convenient from the aircraft. The heading can be observed directly along the line of the fuselage by sighting the tail fin and propeller in the case of single-engine, single-fin aircraft. With multi-engine aircraft, the most convenient line of sight is from the side of the aircraft, sighting across the tips of the propellers. Here, the correct

heading will be 90 deg. above or below that observed on the compass, according as to whether it is set up on the starboard or port side of the aircraft. The compass should be levelled carefully on its tripod and time allowed for the card to settle before taking readings. With care, readings can be taken on the medium landing compass to a fraction of a degree. The observer must ensure that there is no magnetic material either on his person or in the vicinity while taking readings.

64. The aircraft should be lined up by the compass on the measured bearing of the source, and the D/F reading observed. The accuracy to be desired is 0 deg. to $\pm \frac{1}{4}$ deg. If it differs by more than 1 deg. from zero, the discrepancy may be due to any one of the following:—

(a) Site error;

(b) Index incorrectly set;

(c) The D/F loop fitted asymmetrically with respect to the framework of the aircraft.

65. Where the site is well chosen, the measured bearing may be accepted as the reference bearing and the index set accordingly.

66. The aircraft should then be swung through an angle of 360 deg. in steps of 8 to 10 deg. and the compass and D/F scale readings noted and recorded at each point. The bearing reading of the D/F scale should always be taken and not the reciprocal. It will be found helpful if the aircraft is turned anti-clockwise, as then the scale readings will increase from zero to 360 deg.

Determination of quadrantal error

67. The readings thus obtained may now be tabulated, in the manner shown in the example given in the following table. It should be noted that the aircraft heading is added to the D/F scale reading to produce the W/T observed bearing (magnetic). Where the result of this addition produces a figure of more than 360 deg. the correct figure can be determined by subtracting 360 from the addition. The difference between the observed W/T bearing and the measured bearing is the quadrantal error.

Aircraft:	No.:	Where swung:		Stn. on which calibrated:	
		Frequency:	Date:	By whom:	
(a) Aircraft Heading (Magnetic)	(b) D/F Loop Scale Reading	W/T Bearing (Magnetic) Observed (a + b)	W/T Bearing (Magnetic) Measured	Quadrantal Error (deg.)	Remarks
13 deg.	47 deg.	60 deg.	62 deg.	- 2 deg.	Sharp
35½ deg.	24 deg.	59½ deg.	62 deg.	- 2½ deg.	—
299 deg.	126 deg.	(425 - 360) = 65 deg.	62 deg.	+ 3 deg.	—

68. From the table a curve of errors should be drawn on squared paper, the error being plotted against the D/F loop scale reading. In cases where some of the points (errors) do not lie on a smooth curve it is advisable to check these points, paying particular attention to the compass readings.

69. The quadrantal error corrector should now be calibrated and a correction adjustment made in the following manner:—

- (1) If the curve of error shows a greater positive than negative degree of error, or *vice versa*, e.g., + 10 deg. and + 11 deg. with - 5 deg. and - 6 deg. or - 10 deg. and - 11 deg. with + 5 deg. and + 6 deg., the loop and its cursor are not correctly aligned. This fault should be rectified by realigning the loop as described in *para.* 43 to 45, and calibrating again.
- (2) The average error can be found by adding together the maximum error in each quadrant, irrespective of sign, negative or positive, and dividing by 4, e.g., - 4 deg., + 4½ deg., - 4 deg., + 3½ deg. = 16 deg. The average is therefore 4 deg.
- (3) The average error having been found, the selector screw (8, *fig.* 4) should be removed and the corrector rotated until the marking corresponding most nearly to the average error appears in the hole in the long strip. If the average error

falls exactly between two figures (e.g., 5 deg.), then correction should be made to the lower one (i.e., to 4 deg., not 6 deg.). The selector screw should then be replaced and the three hexagon-headed screws (5, 8 and 11) tightened. After tightening, these screws should be locked by turning up the edges of the soft metal washers.

70. The installation then must be recalibrated and the residual errors plotted on the same squared paper as the original curve.

71. From the completed curve the corrections to be applied when using the loop may be plotted on the prepared surface of the scales of both the box drive and the indicator. It must be remembered that the correction is the inverse of the error, e.g., if the error is + 3 deg. the correction to be plotted will be - 3. With the normal working cursors removed and the marking cursors fitted in their place on the box drive and the indicator, the quadrantal error correction curve is drawn in pencil on the prepared surface of each of the scales, using the bevelled edge of the marking cursor as the reference line. This is illustrated in *fig.* 15 and 16. In *fig.* 15 is illustrated the scale of the box drive developed to show the full scale with correction drawn up it, and in *fig.* 16 that of the indicator is shown, also with its correction curve. A marking cursor is illustrated in *fig.* 12. Having completed the curve the marking cursor should be removed and the

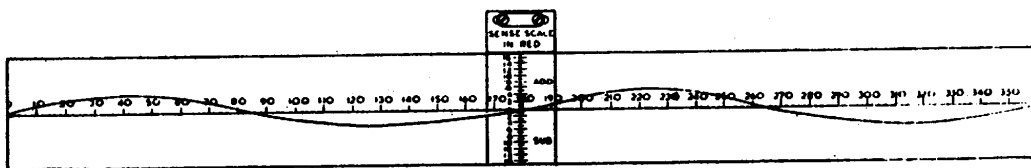

Fig. 15. Scale of box drive, with Q.E. correction curve

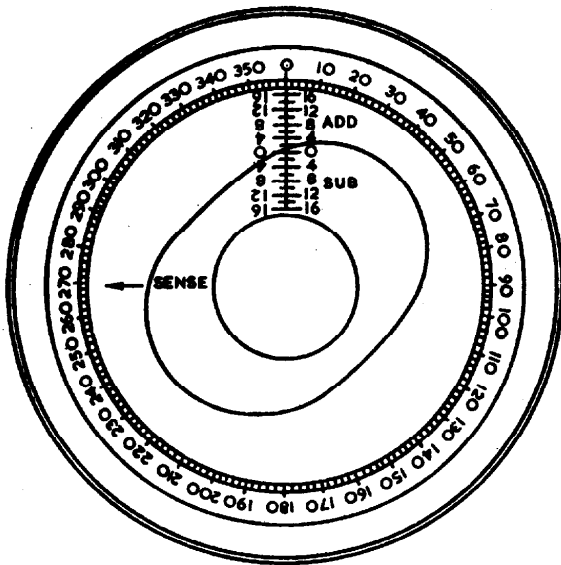

Fig. 16. Scale of indicator, with Q.E. correction curve

normal working cursor replaced in each instance. It is essential before changing cursors to lock the loop rotating drive and to ensure that the reference lines on the cursors are set at the same figure on the scale in the box drive and the indicator. Bearing and correction can now be read directly on each scale.

OPERATION

72. The operation of taking an ordinary D/F bearing resolves itself into the simple process of identifying and tuning the receiver to a suitable transmitter and, with the loop

connected to the receiver, rotating the loop whilst simultaneously listening to the transmitter. The strength of the signal heard in the headphones or shown on the visual indicator will vary as the loop is rotated, and at two points in each revolution of the loop the signal will fall to a minimum. If the scale on the indicator is observed, it will be found that the two readings at which these minima occur are separated by 180 deg. One of these minima is the bearing of the station from the aircraft heading and the other the reciprocal of the bearing.

73. The ambiguity of 180 deg. can be resolved by dead reckoning. It may also be resolved by obtaining a second bearing on the same transmitter a few minutes later, or by obtaining a bearing on another transmitter.

74. To resolve this ambiguity at the same time as the bearing is taken, however, sense finding arrangements are provided. These involve the connection of the fixed aerial, or of a special sense aerial in some cases, to the receiver in a particular manner. As this connection is effected in the receiver, it will not be described here. Full information will be found in Chap. 2.

75. Instructions on the taking of D/F bearings will be found in the appropriate section of the Manual of Air Navigation, A.P. 1234; instructions relevant to the R.1155 receiver will be found in Chap. 2 of this Volume.

APPENDIX I

LIST OF PARTS

The following list is issued for information only. All the parts of the loop aerial or its accessories have not been listed, only the more important spares for which reference numbers have been allocated.

In ordering spares, the appropriate section of A.P.1086 must be used.

Stores Ref.	Name of Part	Remarks
10B/10594	Aerial, loop, Type 3	Wound moulded former only; complete with 4 cradle fixing screws and nuts
10B/420	Aerial, loop, Type 4	Wound moulded former with 4 fixing screws and nuts and including electrostatic screen and clamp plate
10B/10619	Boxes, drive, Type 1	For remote control; with cursor fixing screws
10B/11523	Boxes, drive, Type 2	For direct drive; with cursor fixing screws and brake components
5E/1328	Cable, Dumet 4	
5E/2220	Cable, Duradio 20	
10J/10602	Casing, rigid, Type E2	
10J/8587	Cleats	
10B/21	Coils, Q.E. correction	For Type 3 loop
10B/537	Coils, Q.E. correction	For Type 4 loop
10J/10595	Controllers, Type E2	
10B/11053	Cradles, former	
10B/11472	Cursors, Type 1	
10B/11474	Cursors, marking, Type 1	For initial calibration
10B/538	Disc, support	For Q.E. corrector of Type 4 loop
10B/22	Fittings, alignment, D/F loop, Type 3	For installation of Type 3 loop
10B/13186	Fittings, alignment, D/F loop, Type 4	For installation of Type 4 loop
10J/10601	Fittings, anti-torsional, Type E1	
10B/10591	Housings, nose section	For Type 3 loop, including nose bolt (10B/84), spring washer (10B/141) and captive nut (10B/120)
10B/10592	Housings, centre section	For Type 3 loop
10B/10593	Housings, tail section	For Type 3 loop, with fixing screws
10B/1680	Housings, bakelised fabric, complete	For Type 4 loop; consists of top section (10B/13077), bottom section (10B/13018), and 10 fixing screws
10J/10592	Indicators, Type E2	Complete with one cursor, marking, Type 3 (10B/11637), for initial calibration
10H/9872	Plugs, Type 101	For Duradio 20 extension
10H/433	Plugs, Type 209	For R.1155 receiver

LIST OF PARTS—contd.

Stores Ref.	Name of Part	Remarks
10B/171	Rings, rubber, Type 1	Gasket between housings 10B/10591 and 10B/10592
10B/11470	Scales, box drive, Type 1	Includes 4 fixing screws
10J/8594	Shafting, flexible, Type E2	2 pole
10H/11051	Sockets, Type 63	For Type 3 loop; includes screws, nuts and washers
10B/19	Strips, long, Q.E. correction	For Type 4 loop
10B/20	Strips, short, Q.E. correction	For Type 3 loop, complete with cradle fixing nut and grub screw
10B/535	Strips, Q.E. correction, long	For Type 3 loop, 36 in. long, complete with top bearing and 4 bolts and nuts for fixing flange
10B/536	Strips, Q.E. correction, short	
10B/11054	Tubes, driving	
10B/11524	Tubes, support	
<p><i>Note:</i> Driving and support tubes for the Type 4 loop are available in a range of lengths, both with and without the flange. A.P.1086 should be consulted for full details</p>		
10J/11037	Unions, lubrication, Type E2	
10B/11525	Wheels, hand	